

WP12 Common Rail Euro V Series Diesel Engine Maintenance Manual



Weichai Power Co., Ltd.



WP12 four-valve common rail Euro V series diesel engine

Special Notice

- The operator must read carefully this Maintenance Manual before operating the diesel engine, and must follow strictly the operation and maintenance regulations specified therein.
- The diesel engine has gone through delivery test in strict accordance with the test specifications. Without approval, the ECU data shall not be adjusted to increase the power of diesel engine. Or otherwise all the guarantee commitments of the Company shall become invalid.
- ECU, common rail fuel pump and fuel injector are precision parts, which shall not be disassembled by the user, or otherwise all the guarantee commitments of the Company shall become invalid.
- The rotor spindle of turbocharger is a precision high-speed rotating part. It must not be disassembled or impacted, or otherwise all the guarantee commitments of the Company shall become invalid.
- There are strict torque and rotation angle requirements for main bearing bolts and connecting rod bolts of diesel engine. Therefore, the user shall not loosen or unscrew them. The connecting rod bolts are disposable and shall not be reused, or otherwise all the guarantee commitments of the Company shall become invalid.
- The oil or fuel to be filled in the diesel engine must be of grade specified herein and shall be filtered with special clean filters. The fuel shall be settled for at least 72 hours. Every time before startup, make sure that the volumes of coolant and oil are up to standard.
- The diesel engine must not work without air filter to prevent unfiltered air from entering into the cylinder.
- The diesel engine speed shall be increased gradually after cold start, and shall neither be run at high speed suddenly nor be run at idle speed for a long time (idle time shall not exceed 3min); after running under high load, the engine shall not be stopped immediately (except in emergency), and shall be stopped after running at low speed for 5-10 minutes.
- If the operating environment temperature is below 0°C, and the coolant used is not added with antifreeze additive, then the coolant in the water tank and diesel engine should be drained off after the engine is stopped;
- The overhaul of parts of electrical system must be done by electricians.
- The overhaul of parts of electronic control system must be done by the professionals at maintenance station of Weichai Power.
- The diesel engine is treated with oil sealing upon delivery to prevent rusting. In general, the storage life of diesel engine before unpacking is one year; therefore, it is necessary to check and take necessary remedial measures for those which have been stored for over 1 year.
- The Euro V diesel engine is provided with SCR after-treatment system. To ensure that this system functions properly, once prompted, please immediately add the diesel exhaust fluid made by standard producers. Use of self-made diesel exhaust fluid and other liquids is strictly prohibited, or otherwise all consequences arisen shall not be borne by Weichai.

- Please only fill fuel of specified grade in standard filling stations, or otherwise Weichai shall be exempted from providing guarantee for any damages to fuel system of diesel engine caused by unqualified fuel.
- Euro V dedicated diesel fuel shall be used for Euro V diesel engine, or otherwise Weichai shall not be held responsible for substandard exhaust emission of diesel engine caused by unqualified fuel.
- Please only send the engine to service stations designated by Weichai for overhauling and maintenance. Only spare parts designated by Weichai can be used for maintenance, or otherwise Weichai shall not be held responsible for any damages to diesel engine caused by not using the spare parts designated by Weichai.
- With the replacement of key components (turbocharger, after-treatment system, fuel injection pump, injector, ECU, EGR) that will affect the emission status, make sure that the manufacturers and models of the parts are the same with the previous. In case of failing to do so, Weichai is not to be held responsible for any consequences

PREFACE

This series diesel engine is of high speed diesel engine independently developed by Weichai Power Co., Ltd. This series of diesel engine features compact structure, high reliability, excellent power performance and economy indicators, rapid start, simple operation and convenient maintenance. It is the ideal power for heavy-duty vehicles.

This manual mainly includes the operation precautions, maintenance and service methods, common check and adjustment, and diagnosis and troubleshooting of common faults of WP12 series diesel engine. It should be noted that determining of diesel engine faults requires special carefulness and certain knowledge and experience, do not disassemble the diesel engine before the fault causes are found out. Or else, the fault may not be eliminated, or even become more serious due to improper reassembling, particularly the key parts such as electronic control system and turbocharger, for which special instrument or equipment shall be used in checking and maintaining. Users inexperienced or having no special equipment shall not disassemble or adjust the diesel engine randomly.

This manual introduces the basic model of WP12 series diesel engine. With the development and improvement of products, the contents of this maintenance manual may be lagged; users or dealers can visit the Weichai website <http://www.weichai.com> for the latest product information.

Welcome comments and suggestions from users for our further product improvement.

Aug 2016

CONTENTS

Part I Instructions for Use of the Diesel Engine	9
1.1 Outline drawing of the diesel engine	9
1.2 Diesel engine model meaning	13
1.3 Basic parameters of the diesel engine	13
1.4 Unsealing of the diesel engine	14
1.5 Hoisting of the diesel engine	14
1.6 Preparations before startup	15
1.7 Engine startup	16
1.8 Running of the diesel engine	16
Part II Diesel Engine Maintenance Guide	18
2.1 Fuel, lubricating oil, coolant, urea solution and auxiliary materials	18
2.1.1 Fuel	18
2.1.2 Lubricating oil	18
2.1.3 Diesel engine coolant	19
2.1.4 Urea solution	19
2.1.5 Auxiliary material	20
2.2 Routine maintenance	21
2.3 Maintenance items	23
2.4 Maintenance for Long-Term Storage of Diesel Engine	30
2.4.1 Clean the diesel engine	30
2.4.2 Protection during storage	30
2.4.3 Oil sealing	31
Part III Common Failures and Troubleshooting	32
3.1 Diagnostic method	32
3.2 Common failure causes and troubleshooting	33
3.2.1 Diesel engine cannot be started up	33
3.2.2 The engine is difficult to start up	34
3.2.3 Insufficient engine power	34
3.2.4 The engine always runs at 1000r/min	35
3.2.5 Engine idling speed unstable	35
3.3 After treatment system failure diagnosis and troubleshooting	36
3.3.1 Failure analysis of after treatment system component	36
3.3.2 Fault diagnosis of after treatment system and troubleshooting	50
Part IV Diesel Engine Disassembly and Assembly	56
4.1 Overview	56
4.1.1 Danger signs	56
4.1.2 Safety signs	57
4.1.3 Tools used	58
4.1.4 Health protection considerations	58
4.1.5 Environmental protection measures	59
4.1.6 Considerations for engine disassembly and assembly	59
4.2 Engine Block Group	59
4.2.1 Disassembly and assembly of engine block group	59
4.2.2 Disassembly and assembly of cylinder block preassembly	61

4.2.3 Disassembly and assembly of piston cooling nozzle	62
4.2.4 Disassembly and assembly of thrust plates.....	63
4.2.5 Disassembly and assembly of front and rear oil seals	64
4.2.6 Disassembly and assembly of front end cover.....	64
4.2.7 Disassembly and assembly of flywheel casing.....	65
4.2.8 Disassembly and assembly of oil pan	67
4.2.9 Disassembly and assembly of cylinder head	68
4.2.10 Disassembly and assembly of cylinder head cover.....	74
4.2.11 Disassembly and assembly of engine lifting eye	75
4.2.12 Disassembly and assembly of oil-gas separator.....	76
4.2.13 Disassembly and assembly of oil dipstick	77
4.2.14 Disassembly and assembly of oil filling pipe	78
4.2.15 Disassembly and assembly of air bleeder	78
4.3 Crankshaft connecting rod system.....	80
4.3.1 Disassembly and assembly of crankshaft connecting rod system.....	80
4.3.2 Disassembly and assembly of crankshaft flywheel group	80
4.3.3 Disassembly and assembly of piston and connecting rod mechanism.....	84
4.3.4 Disassembly and assembly of connecting rod bearing	87
4.3.5 Disassembly and assembly of vibration damper and crank pulley	88
4.4 Valve train	88
4.4.1 Disassembly and assembly of valve train	88
4.4.2 Disassembly and assembly of camshaft.....	89
4.4.3 Disassembly and assembly of rocker arm and rockshaft	91
4.4.4 Disassembly and assembly of tappet and push rod.....	93
4.4.5 Disassembly and assembly of valve	94
4.4.6 Disassembly and assembly of intermediate gear	95
4.5 Intake and exhaust system	96
4.5.1 Disassembly and assembly of intake and exhaust system	96
4.5.2 Disassembly and assembly of intake manifold.....	97
4.5.3 Disassembly and assembly of exhaust manifold	98
4.5.4 Disassembly and assembly of turbocharger.....	99
4.6 Fuel system	100
4.6.1 Disassembly and assembly of fuel system.....	100
4.6.2 Disassembly and assembly of common rail pipe.....	101
4.6.3 Disassembly and assembly of ECU	101
4.6.4 Disassembly and assembly of fuel injection pump.....	102
4.6.5 Disassembly and assembly high pressure fuel pipe	104
4.6.6 Disassembly and assembly of fuel injector.....	105
4.6.7 Disassembly and assembly of fuel filter	106
4.6.8 Disassembly and assembly of low pressure fuel pipe.....	107
4.6.9 Disassembly and assembly of harness	109
4.7 Cooling system	110
4.7.1 Overview of cooling system	110
4.7.2 Disassembly and assembly of water pump	111
4.7.3 Disassembly and assembly of thermostat	112
4.7.4 Disassembly and assembly of fan.....	113



4.7.5 Disassembly and assembly of belt and tensioner.....	114
4.8 Lubricating system.....	115
4.8.1 Overview of lubricating system.....	115
4.8.2 Disassembly and assembly of oil pump.....	117
4.8.3 Disassembly and assembly of oil filter and oil filter seat	118
4.8.4 Disassembly and assembly of oil cooler cover	119
4.8.5 Disassembly and assembly of oil cooler.....	119
4.8.6 Disassembly and assembly of oil pump strainer.....	120
4.9 Starting system	121
4.9.1 Disassembly and assembly of starting system.....	121
4.9.2 Disassembly and assembly of starter	122
4.10 Accessories system of the vehicle	123
4.10.1 Disassembly and assembly of accessories system of vehicle	123
4.10.2 Disassembly and assembly of alternator.....	124
4.10.3 Disassembly and assembly of air-conditioner compressor.....	125
4.10.4 Disassembly and assembly of air compressor	126
4.10.5 Disassembly and assembly of hydraulic pump.....	127
Part V Tightening of Main Bolts of the Engine.....	129
5.1. Main bearing bolts	129
5.2. Cylinder head bolts	129
5.3. Connecting rod bolts.....	130
5.4 Flywheel bolts.....	130
5.5 Tightening torques and methods of other bolts and nuts	130
Appendix A: Diagnostic Trouble Code Table	133
Appendix B: Fitting clearances for diesel engine main parts	195
Appendix C: Evaluation benchmark for wear of main friction pairs of the diesel engine.....	197

Part I Instructions for Use of the Diesel Engine

1.1 Outline drawing of the diesel engine

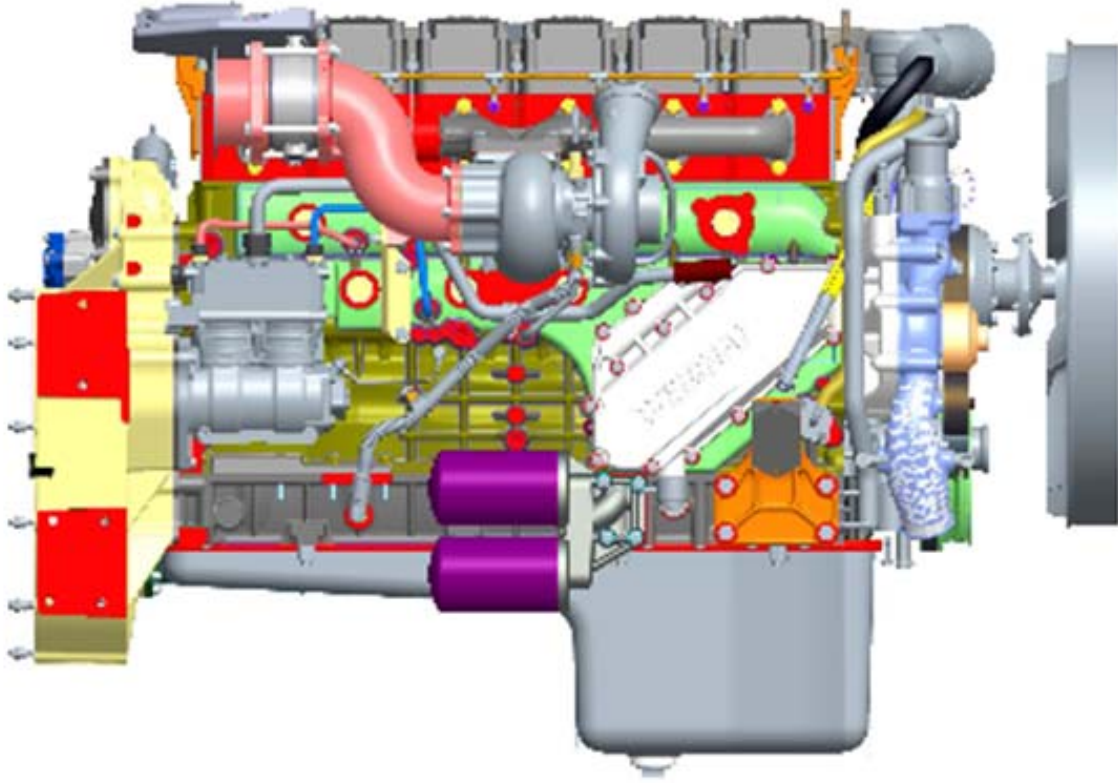

Figure 1-1 Outline drawing of WP12 four-valve Euro V series diesel engine

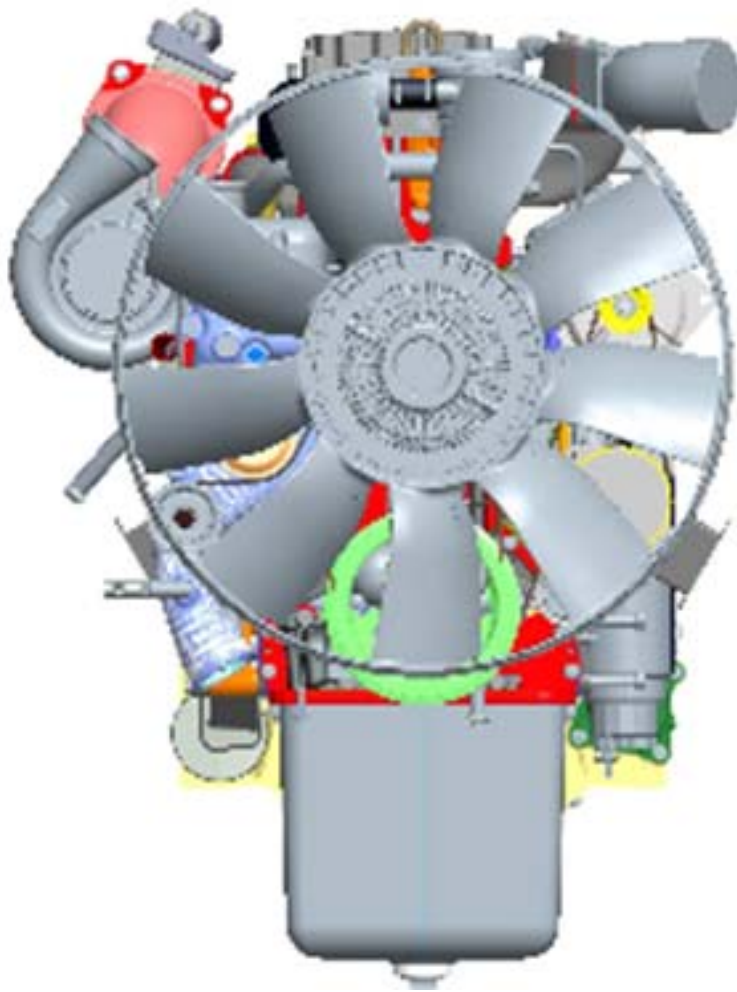

Figure 1-2 Free end of WP12 four-valve Euro V series diesel engine

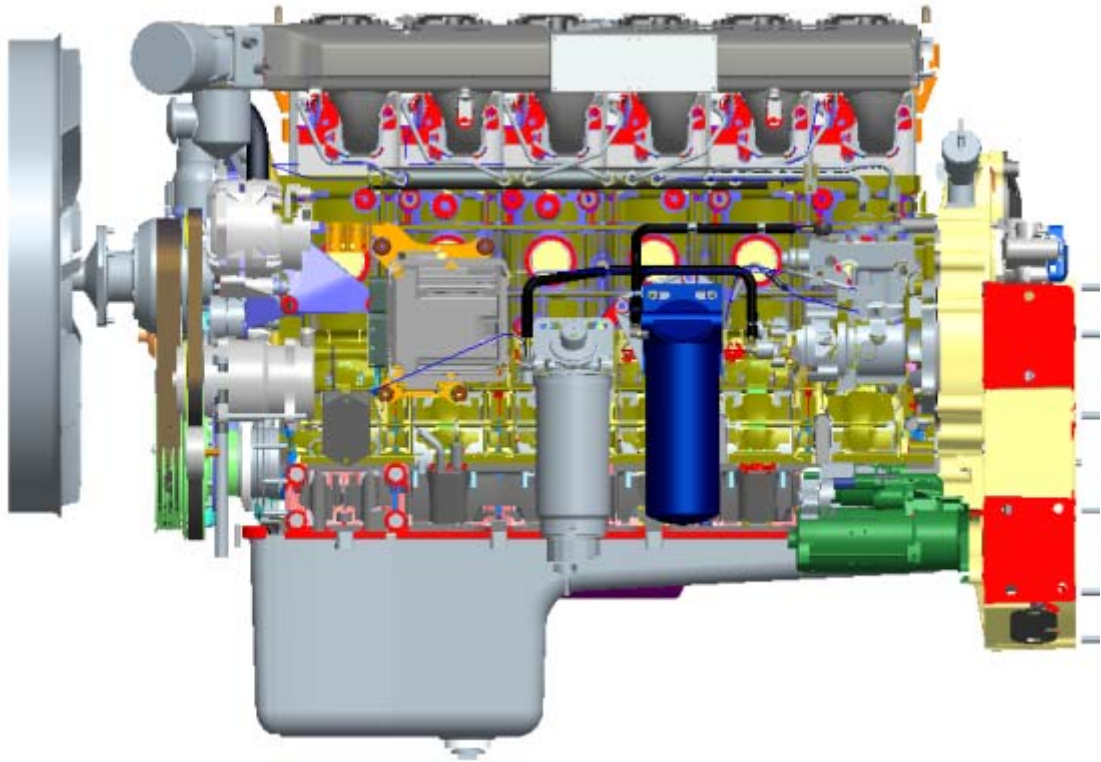

Figure 1-3 Intake side of WP12 four-valve Euro V series diesel engine

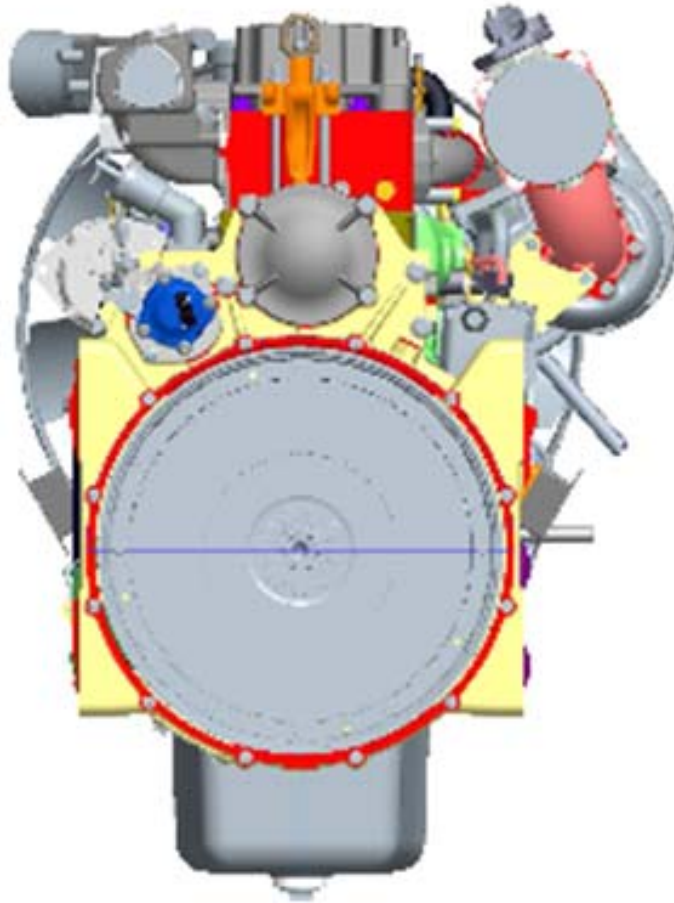
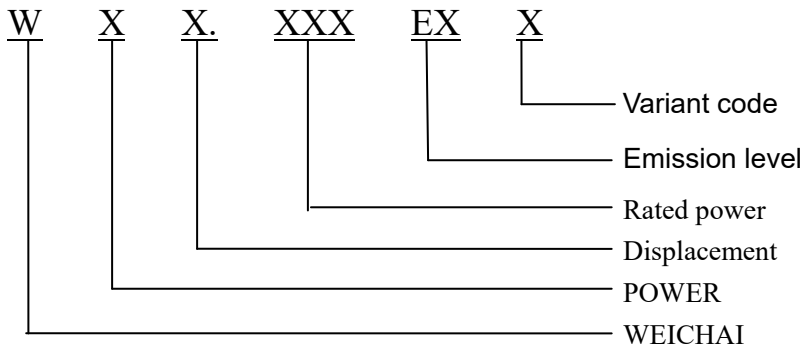

Figure 1-4 Flywheel end of WP12 four-valve Euro V series diesel engine

1.2 Diesel engine model meaning



1.3 Basic parameters of the diesel engine

Table 1-1 Performance parameters of WP12 Euro V series diesel engines

Model	Unit	WP12							
		480E40	460E40	430E40	400E40	375E40	336E40	300E40	270E40
Engine type		Inline, water cooled, four stroke, direct injection							
Intake mode		Turbocharged and intercooled							
Bore/stroke	mm/mm	126/155							
Displacement	L	11.596							
Rated power	kW	353	338	316	294	276	247	221	199
Rated speed	r/min	2100	1900						
Max torque	Nm	1970	2110	2060	1920	1800	1600	1440	1300
Speed at max torque	r/min	1200~1500	1000~1400						
Max no-load speed	r/min	2310	2150						
Idling speed	r/min	600±50							
Net weight	kg	1050±50							

Table 1-1 Performance parameters of WP12 Euro V series diesel engines (continued)

Model	Unit	WP12					
		336E41	375E41	400E41	430E41	460E41	480E41
Engine type		Inline, water cooled, four stroke, Direct injection					
Intake mode		Turbocharged and intercooled					

Bore/stroke	mm/mm	126/155					
Displacement	L	11.596					
Rated power	kW	247	276	294	316	338	353
Rated speed	r/min	2100					
Max torque	Nm	1450	1630	1780	1920	1970	1970
Speed at max torque	r/min	1200~1500					
Max no-load speed	r/min	2310+10					
Idling speed	r/min	600±50					
Net weight	kg	1050±50					

1.4 Unsealing of the diesel engine

After unpacking the diesel engine, check the diesel engine and its accessories according to the Packing List, check the diesel engine appearance and connecting parts, and carry out the following operations:

- 1) Wipe antirust layer and anticorrosive agent on the exposed parts.
- 2) Drain off the oil sealing oil from the fuel filter and other components of fuel system (the engine can also be started without draining off the oil sealing oil in the fuel system, but should not run with heavier load unless the sealing oil in the fuel system has been used up and the normal fuel supply is guaranteed).

Note: The oil seal of this diesel engine is only effective for one year, and when the time is up, please get your engine inspected and take necessary remedies.

- 3) Rotate the flywheel and spray solvent into the intake pipe until the oil sealing oil in the cylinder is completely removed.
- 4) Spray solvent into the turbocharger intake/exhaust ports until the oil sealing oil is completely removed.
- 5) Base on the agreement between manufacturer and user, the oil pan shall be filled with oil in accordance with the requirement; if oil containing running-in accelerant is filled in the oil pan before delivery, it is suggested that the oil should be drained off after driving the vehicle for 2000km or 50h and then fill with new oil.
- (6) Base on the agreement between manufacturer and user, if the coolant is already filled according to the user's requirement before delivery, please check the coolant performance when unpacking. If the antifreezing capability is suitable for -30°C or -35°C, the PH value is 7~8 (neutral), the total hardness number is 5-15°d [9-15°f (hardness)], the coolant can be used. Otherwise, drain the coolant and add new coolant which contains antifreeze additives.

1.5 Hoisting of the diesel engine

When hoisting the engine, keep the engine crankshaft centerline horizontal, and never hoist it obliquely or from

one side. Engine hoisting and setting should be slow (as shown in figure 1-5).

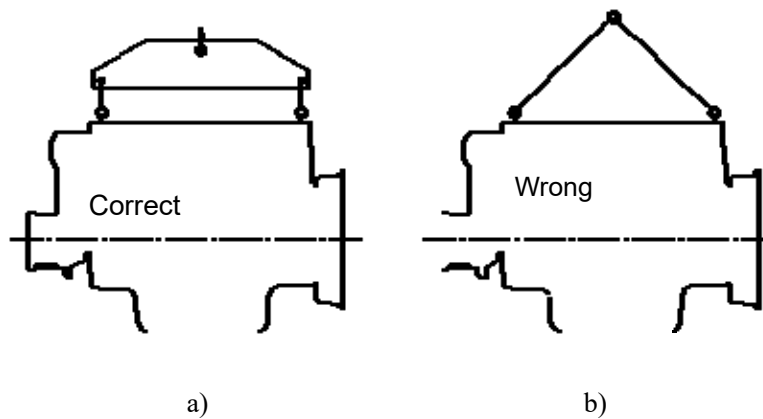

Figure 1-5 Hoisting of the engine

1.6 Preparations before startup

1) Check coolant level

If the engine has been installed on the vehicle or bench, the coolant should be at such level that it is visible from the sight hole on the expansion tank; if not, open the filler cap and refilling. If the engine is still hot when the filler cap with relief valve and bleed button is to be opened, always press down the bleed button first. Never add a lot of coolant when the engine is relative hot; otherwise, related parts may get damaged due to sudden excessive temperature change. If there is no proper coolant under some abnormal cases, it is permissible to add relatively warm water. The coolant (water) should be added via the filler port until it overflows. Start the engine, and when the engine is running (at 1000 r/min), continue to add coolant till the level is stable, and then cover the filler cap.

2) Check fuel level

If the engine has been installed on the vehicle, it is recommended to turn on the power switch and check the fuel level through the fuel gauge or check the fuel tank correctly.

3) Check engine oil level

The oil level should be in between the upper and lower marks of the dipstick; when necessary, add oil from the filler port.

4) Check urea solution level in urea tank

Generally, the urea consumption accounts for 3~5% of the fuel consumption (by volume). Check the level of urea solvent depending on the working condition. Maintain the level at 30~80% and timely add if insufficient. Do not add excessive urea, or it will lead to overflow of urea.

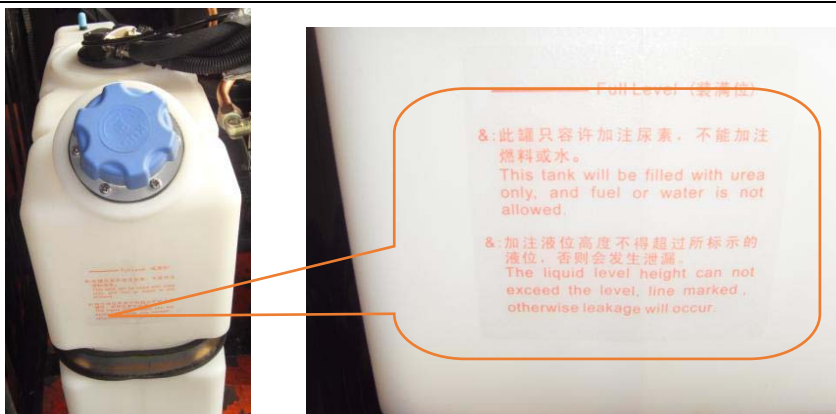

Figure 1-6 Urea level Identification on urea tank

5) Check various accessories of diesel engine

Check if various accessories of diesel engine are connected reliably, and eliminate all abnormalities. Check if the wiring of starting system is normal and if the battery is fully charged. After this, open the fuel tank valve, loose the bleeding screw on the filter and operate the hand pump to remove the air in the fuel system. Check the connection of pipeline of SCR system for urea solution leakage, tighten the connection if necessary.

1.7 Engine startup

- 1) Turn the power switch and electric key to the starting positions, and switch gear lever to the neutral position.
- 2) Press down the clutch pedal and throttle pedal, and turn the ignition key to start the engine. The engine may be started in three times of attempts (interval between two successive attempts should be 2 minutes) under the following conditions:

Table 1-2 Starting time of the engine

Start aid	Starting temperature (°C)	Starting time (s)	Starting voltage (V)
Without start aid	-10	≤15	24±4
With electric heating start aid	-30	≤30	

If the engine still fails to be started after three times of attempts, do not try to start the engine unless the causes are found out and the failure is eliminated. After the engine is started, check the readings of instruments. The engine oil pressure gauge shall immediately indicate a pressure. Do not immediately have the cold engine running at a high speed.

- 3) It is recommended to use the starting aid in case of engine startup at a low temperature. Under the action of relay, the electronic flange is put into service and then heats the incoming air, allowing a smooth startup of the engine at -30°C.

1.8 Running of the diesel engine

- 1) After the engine is started, run it at idle speed for 3 minutes, and then increase the speed to 1,000r/min-1,200r/min, and add some load. Only when the water outlet temperature is higher than 60°C and the oil temperature is above 50°C, can you operate the engine with full-load. It is recommended to increase the load and speed gradually, and avoid sudden loading or unloading as possible.
- 2) It is recommended to run the engine under medium load during the running-in period of 60h (for the first 3,000

km driving). Vehicle runs without trailer.

3) Speed down timely when running on a slope. Long term work under large torque condition, small load, and low rotating speed are not recommend, for which may lead to excessive oil consumption.

4) The diesel engine is allowed to run continuously at rated power and rated speed, but only for 20 min at 105% of rated speed and 110% of rated power. After the diesel engine is unloaded, it is required to run the engine at an idle speed for (1~2) min before shutdown.

5) Check the parameters and related components in operation:

Pressure in main oil passage: 350kPa-550kPa (rated point), 130kPa-250kPa (idling point);

Oil temperature in oil pan: $\leq 110^{\circ}\text{C}$;

Coolant outlet temperature: 71°C , 76°C or 83°C depending on engine model;

Exhaust temperature after turbine: $\leq 600^{\circ}\text{C}$;

Intake temperature after intercooler: 45°C - 50°C (1900r/min);
 50°C - 55°C (2100r/min).

Check the color of exhaust gas to identify the working performance of fuel injector and the operating load; if the color is abnormal (heavy black or white smoke), stop the engine for inspection.

CAUTION: Check the diesel engine for water leakage, air leakage and fuel/oil leakage during operation; and if any, do troubleshooting.

6) The operator should acknowledge the following features of the engine:

- ① The fuel consumption is relatively low at max torque, and increases along with the rotation speed rise.
- ② The torque reaches its peak value within the medium speed range (1,200 - 1,700 r/min);
- ③ The engine power increases along with the speed rise, and reaches its rated value at rated speed.

7) Pay attention to the followings when the engine is operating in the cold environment:

- ① Fuel: Select the proper grade of diesel fuel according to the ambient temperature in winter;
- ② Lubricating oil: Select different viscosity grade of lubricating oil based on the season;
- ③ Coolant: Add anti-freeze into the cooling system, and determine the antifreeze grade and mixture ratio according to the ambient temperature.
- ④ Startup: Use starting aid in winter when necessary. The running speed and load of diesel engine can be increased only after the oil pressure and water temperature become normal.
- ⑤ Battery: Before the cold season comes, be sure to check the electrolyte level, viscosity and unit voltage of the battery; and if the diesel engine is to be withdrawn out of service for a long time and the ambient temperature is extremely low, it is recommended to remove the battery and keep it in a warm room;
- ⑥ Shutdown: If it is to shut down the vehicle in chilly days, unload the engine first, and run it at idle speed for (1~2) minutes, and wait for a while until the temperature lowers down; the coolant with antifreeze should not be drained out after shutdown. However, if there is no antifreeze in the coolant, open drain valves or drain plugs on the engine block, oil cooler cover, radiator and water inlet pipe to drain the coolant, preventing the engine from being frost cracked.

Part II Diesel Engine Maintenance Guide

2.1 Fuel, lubricating oil, coolant, urea solution and auxiliary materials

2.1.1 Fuel

Summer: 0# diesel fuel (GB252).

Winter: usually -10# diesel fuel (GB252), or -20# diesel fuel when the ambient temperature is below -20°C, or -35# diesel fuel when the ambient temperature is below -30°C.

All fuels should meet with the specifications in Table C.6 of Appendix C in GB17691-2005 (revised in June 2008).

2.1.2 Lubricating oil

Oil capacity of WP12 diesel engine: 28L (truck engine), 25L (bus engine), 30L (power generating engine). For Weichai Power Euro V series diesel engine, grade CI-4 oil should be used. More details see table 2-1.

Table 2-1 Engine oil special for Weichai Power engine and applicable engine model

Type	Designation and grade		Packing	Applicable engine models
Diesel engine oil	CF-4	10W/30 15W-40 20W-50	4L, 18L, 170kg	China II WD615, WD10, WD618, WD12 and 226B series diesel engines
	CH-4	10W/30 15W-40 20W-50	4L, 18L, 170kg	China III WP4, WP5, WP6, WP7, WP10, WP12 and WP13 series diesel engines
	CI-4	10W/30 15W-40 20W-50	4L, 18L, 170kg	Euro V WP4, WP5, WP6, WP7, WP10, WP12 and WP13 series diesel engines
	CJ-4	10W/30 15W-40 20W-50	4L, 18L, 170kg	China V WP4, WP5, WP6, WP7, WP10, WP12 and WP13 series diesel engines
Special oil for gas engine	10W-30 15W-40	4L, 18L, 170kg	Natural gas engines	

Please see Table 2-2 to choose the oil viscosity according to the temperature.

Table 2-2 Oil viscosity and applicable temperature

SAE viscosity grade	Applicable temperature (°C)
10W-30	-25~30
15W-40	-20~40
20W-50	-15~50

CAUTION:

- 1) Check engine oil level in the oil pan before starting the diesel engine.
- 2) Do not check engine oil level while the diesel engine is running.
- 3) Weichai Power special oil shouldn't mixed with oil from other manufacturers.

For oil filling volume and filter element number of various models, please refer to table 2-3.

Table 2-3 Oil filling volume and filter element number of various engine models

Engine model	Oil filling volume (L)	Filter number				
		Diesel engine			Gas engine	
		Oil filter	Diesel filter		Oil filter	Gas filter
			Primary filter	Secondary filter		
WP4	9~12	1	1	1	1	1
WP5	13~16	1	1	1	1	1
WP6	16~24	1	1	1	1	1
WP7	20~24	1	1	1	1	1
WP10	22~26	2	1	1	2	1
WP12	25~28	2	1	1	2	1
WP13	25~28	2	1	1	2	1

Remarks:

- The oil filling volumes listed are for reference only, the actual filling volume shall subject to the marks of oil dipstick.
- If the vehicle is equipped with Weichai fuel system protector or fuel filter/water separator, their filter elements shall be replaced when replacing the diesel filter.

2.1.3 Diesel engine coolant

Weichai special coolants with freezing point of -25°C , -35°C and -40°C are available. Please choose the coolant according to local temperature in principle that freezing point should be 10°C lower than local temperature. See Table 2-4.

Table 2-4 Weichai Power special coolant for heavy duty engines

Product	Coolant type	Packing specification
Coolant used for heavy-duty engine	HEC-II-25	4kg, 10kg
	HEC-II-35	
	HEC-II-40	

Note:

- Coolant should be checked and renewed regularly to avoid corrosion.
- Water or inferior coolant are prohibited to be used for engines.

2.1.4 Urea solution

The inappropriate urea solution will easily lead to poisoning failure of SCR catalyst or insufficient reduction rate (For instance, the out-of-tolerance of phosphor, sodium, potassium, and calcium contents in the urea solution will

easily lead to poisoning of catalyst and the out-of-tolerance of urea solution concentration will easily lead to excessive leakage of NH₃ or insufficient reduction rate of NO_x) and out-of-tolerance of emission and warning of malfunction indicator lamp. Therefore, the quality and the performance of urea solution in use shall meet the requirements specified in standard ISO 22241 (as shown in table 2-5).

Table 2-5 Urea solution specifications as per ISO 22241

Items	Unit	Minimum	Maximum
Urea content	% by weight	31.8	33.2
Density at 20°C	kg/m ³	1087	1093
Refracting index at 20°C	-	1.3814	1.3843
Alkalinity as NH ₃	%	-	0.2

2.1.5 Auxiliary material

Table 2-6 Auxiliary material and application

No.	Name	Color	Function and application
1	Molykote Pulver (fine molybdenum powder)	Black	Applied on smooth metal surfaces to prevent seizure For instance: Applied onto outer surfaces of cylinder liner
2	Molykote G-N plus (Molybdenum disulfide, oil solution)	Dark grey	Achieve lubrication function before lubricating oil pressure is built up For instance: Applied onto intake valve stem

Table 2-7 Application of sealant for diesel engine

Trademark	Main Applications	List of locations for application of sealant	Additional description
Weichai special sealant 242	It's applied onto the threads to prevent being vibrated to looseness, with moderate strength.	Flywheel housing bolt Camshaft thrust plate bolt Camshaft timing gear bolt Intermediate idler bolt Front end cap bolts Engine oil filter seat bolt Engine oil cooler bolt Screw plug of engine oil cooler regulator valve Bolt of oil pump return pipe fixing device Air compressor shaft end thread Strainer bolt Bolt of sensor and harness fixing device	Alternatively, the DriLoc204 thread pre-application sealant can be pre-applied
Weichai special sealant 262	It's applied onto the external threads to lock, seal, and prevent being vibrated to looseness	Cylinder head auxiliary bolt	
Weichai special sealant 271	Locking and tightening	Bowl plug for oil port	
Weichai special sealant 277	For sealing between element and bore	Other bowl plugs	

Weichai special sealant 270	For sealing top surface of cylinder head	Push rod tube – Cylinder head	
Weichai special sealant 518 (Updated product of 510)	It's applied onto shining metal surfaces for sealing purpose.	Mating face between cylinder block and crankcase Between front end face of engine block and front end cap and between rear end face and flywheel housing connecting plate Mating face between engine oil filter seat and crankcase Water pump rear cap – Engine block front end face Flywheel housing connecting plate – Flywheel housing Mating face between cylinder block and engine oil cooler Mating face between cylinder block and engine oil filler port cover	

2.2 Routine maintenance

- Check coolant level and temperature

Check the coolant level through the sight hole, and if it is not enough, open the filler cap to add coolant. Safety sign and expansion water tank are shown in Figure 2-1 and 2-2.

CAUTION: Before opening the filler cap, press down the bleeding button to avoid scalding by the hot coolant while the engine is hot.

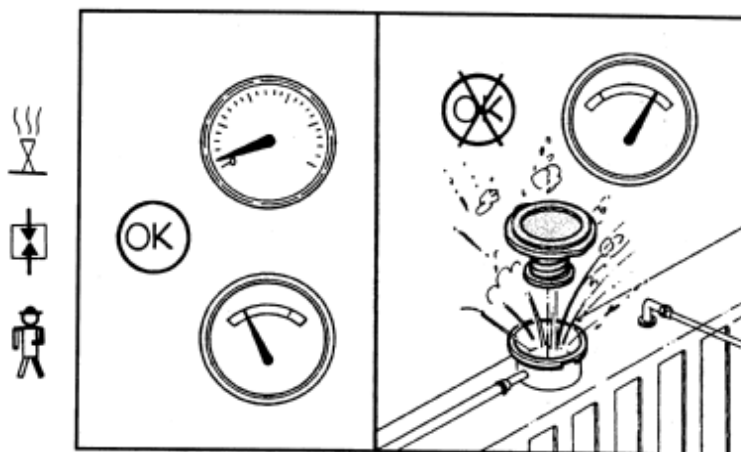

Figure 2-1 Safety sign for filler cap

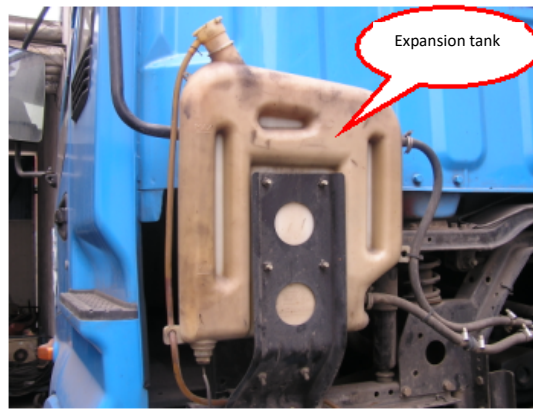

Figure 2-2 Expansion tank

- Check oil level

When the oil level is below the “L” mark or above the “H” mark, it is not allowed to start the diesel engine.

Check the oil level at least 5 min after shutdown, enabling the oil to return to the oil pan.

The oil volume difference between the “L” and “H” marks of dipstick is about 3L. See figure 2-3.

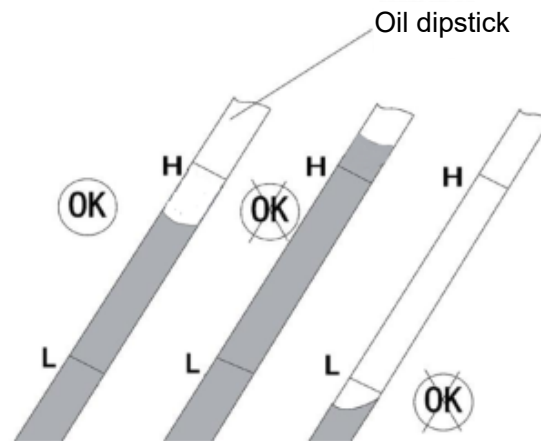

Figure 2-3 Oil dipstick

- Check fuel level

Check the fuel level through dashboard, and add fuel timely.

- Check for leakages (air leakage, water leakage and oil/fuel leakage)

Check the surface of diesel engine for water leakage, air leakage and oil/fuel leakage.

- Check the urea liquid level

The urea liquid level should be at 30%-80% of tank capacity.

- Check the fan

Visually check if the fan blade is damaged, if connecting bolt is fastened tightly. As shown in figure 2-4.

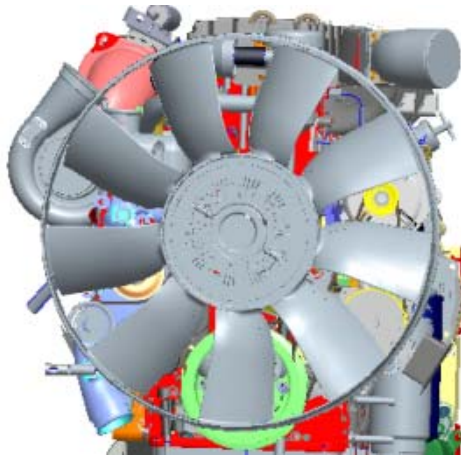

Figure 2-4 check the fan

- Check the belt

The belt is automatically tensioned by a tensioner. To check its tension, press the belt by hand. See figure 2-5.

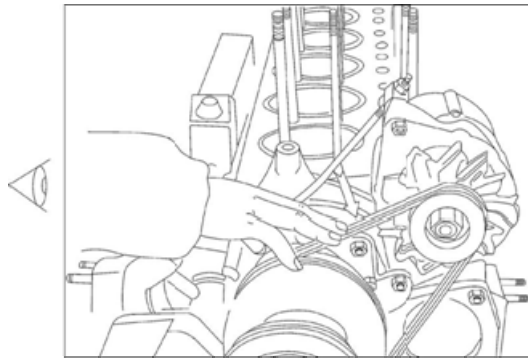

Figure 2-5 check the belt

- Check if the exhaust color is normal, see figure 2-6.



Figure 2-6 check the air tube

The exhaust color is normally light gray. If the color changes, please check the reason for troubleshooting.

- Check if the running sound is normal.
- Check if the speed and vibration of diesel engine are normal.

2.3 Maintenance items

Beside the daily maintenance, the following items should also be performed:

- Replace the oil

Unscrew the drain plug at the bottom of oil pan, and after the oil drains out, screw the drain plug again, see Figure 2-7. Open the filler cap, add oil through the filler port and check the oil level through the dipstick, then tighten the filler cap.

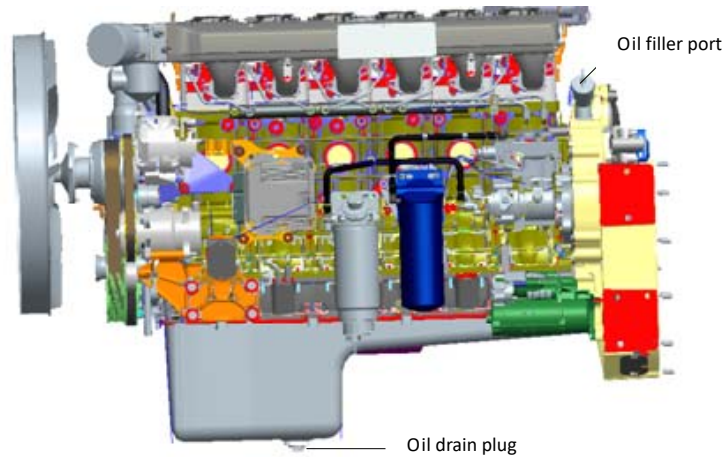
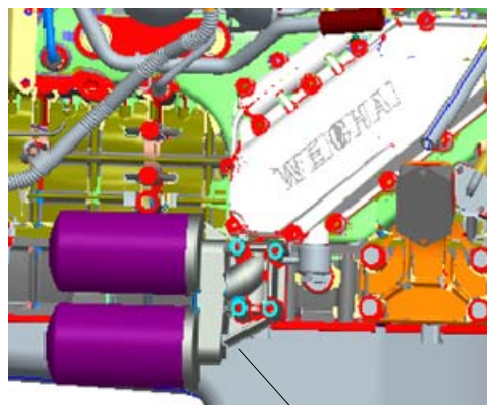

Figure 2-7 Oil filler port, oil drain plug and oil filter

Caution: The waste oil should be placed at designated location and container for recycling.

- Replace the oil filter or oil filter element
 - ① Remove the old oil filter;
 - ② Fill the new filter with clean oil;
 - ③ Apply oil to the sealing washer of new oil filter.
 - ④ When the rubber washer contacts with the base seat, tighten the filter by another 3/4 to 1 turn for a proper tightness;
 - ⑤ Start the diesel engine and check for oil leakage.



Oil filter

Figure 2-8 Oil filter

- Check and adjust intake/exhaust valve clearance

Check and adjust intake/exhaust valve clearance as follows:

- (1) With the diesel engine in cold state, turn the flywheel with a bar (following the running direction of diesel engine crankshaft) to make the No. 1 cylinder and No. 6 cylinder to TDC, when the notch groove on flywheel should be aligned with the pointer on the flywheel housing cover plate. As shown in figure 2-9.

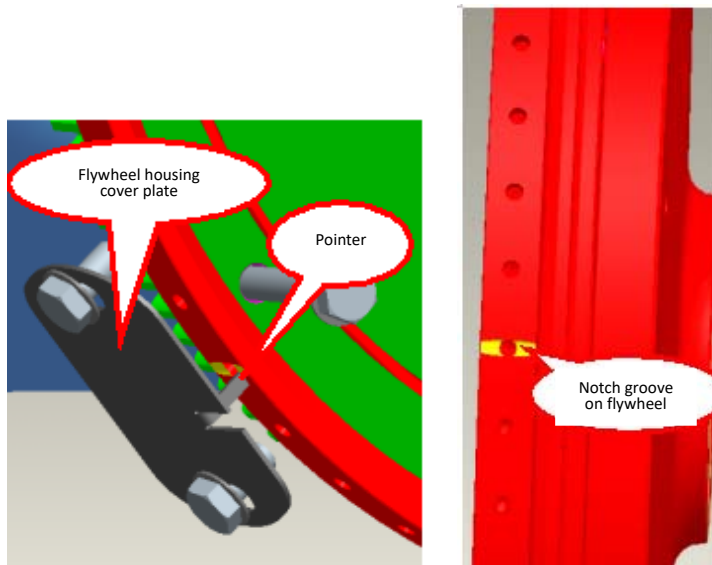

Figure 2-9

- (2) Remove the valve rocker arm cover on the cylinder head, and determine if the No. 1 cylinder or No. 6 cylinder is in the compression stroke (as indicated by the existence of clearance between the intake/exhaust valve and the rocker arm).

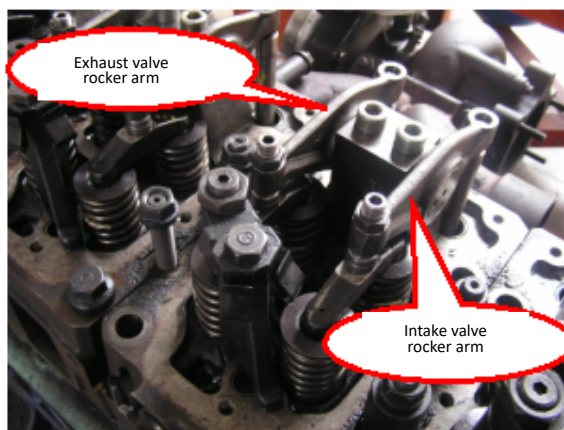

Figure 2-10 Adjustment of valve clearance

- (3) Check the clearance between the upper plane of valve bridge and valve rocker arm with feeler gauge. If the clearance is excessive or too small, please adjust the adjusting bolt on the rocker arm to achieve the proper valve clearance.

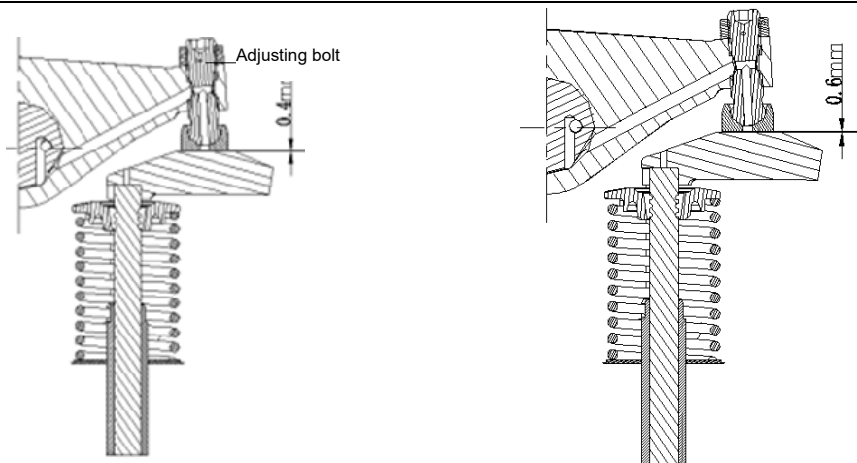

Figure 2-11 Intake valve clearance 0.4mm (Cold state) Figure 2-12 Exhaust valve clearance 0.6mm (Cold state)

After checking the No. 1 or No. 6 cylinder, turn the flywheel by 360°, ensuring that the No. 6 cylinder or No. 1 cylinder is at TDC of working stroke, and then adjust the remaining valves.

Table 2-8 State of each cylinder when the No. 1 and No. 6 cylinders are in working stroke

	No. 1 cylinder	No. 2 cylinder	No. 3 cylinder	No. 4 cylinder	No. 5 cylinder	No. 6 cylinder
No. 1 cylinder, compression stroke	Intake/exhaust valves	Intake valve	Exhaust valve	Intake valve	Exhaust valve	Unadjustable
No. 6 cylinder, compression stroke	Unadjustable	Exhaust valve	Intake valve	Exhaust valve	Intake valve	Intake/exhaust valve

For the exhaust valve with EVB, the adjustment is as follows (figure 2-13):

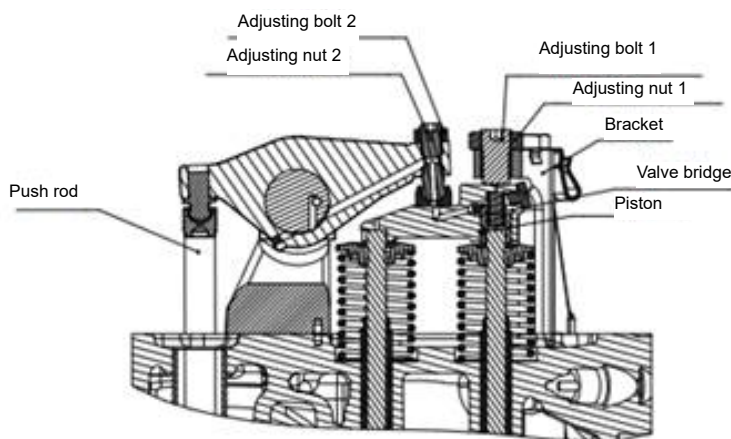

Figure 2-13 Adjustment of exhaust valve and EVB clearances

- a) With the piston at TDC;
- b) Loose the adjusting nut 1.

Adjust the adjusting bolt 1 until the contacting clearance between the bolt and the valve bridge is 0.

- c) Loose nut 2

Adjust the adjusting bolt 2, and insert a 0.6mm feeler gauge in between the bolt 2 and the valve bridge.

d) Adjust the adjusting bolt 2 until the small piston is pressed down completely and the feeler gauge is clamped

Adjust valve clearance 0.6mm, rotate the adjusting bolt till the feeler gauge is clamped, then lock the nut.

e) Adjust the adjusting bolt 1, and insert a feeler gauge (0.4mm) in between the valve bridge and adjusting bolt 1.

Adjust the adjusting bolt 1 until the small piston is pressed down completely and the feeler gauge is clamped, and then lock the nut.

- Replace the fuel filter element

Replace steps of fuel filter element (see figure 2-14):

- ① Dismantle the old fuel filter element; take down the water collector which installed on primary fuel filter if it could be reused.
- ② Lubricate the sealing port.
- ③ Screw the filter till the sealing port is coupled with the interface.
- ④ Continue to screw (turn about 3/4 circle) the filter till it's installed firmly.
- ⑤ Remove the air in fuel system.
- ⑥ Carry out leakage test.

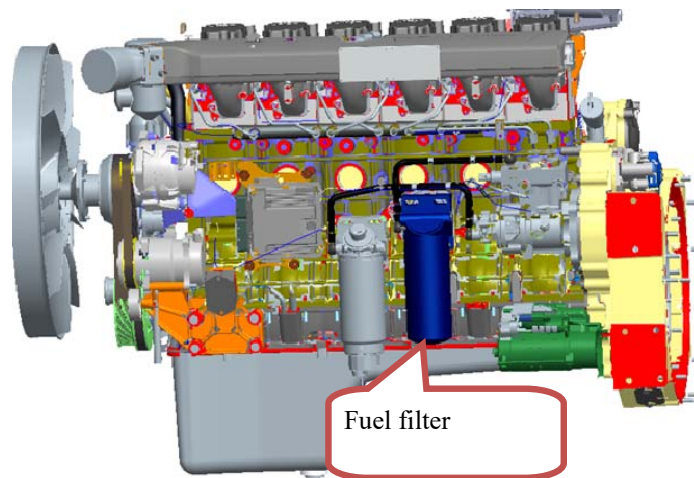

Figure 2-14 Fuel filter

Note: When replacing the primary spin-on filter or reinstalling fuel pipe, remove the air in the primary filter (see figure 2-15).

- ① Shut the engine down.
- ② Dismantle the bleeding screw plug on the primary fuel filter.
- ③ Pumping fuel with hand pump until only fuel comes out from the bleeding screw plug.
- ④ Retighten the bleeding screw plug.

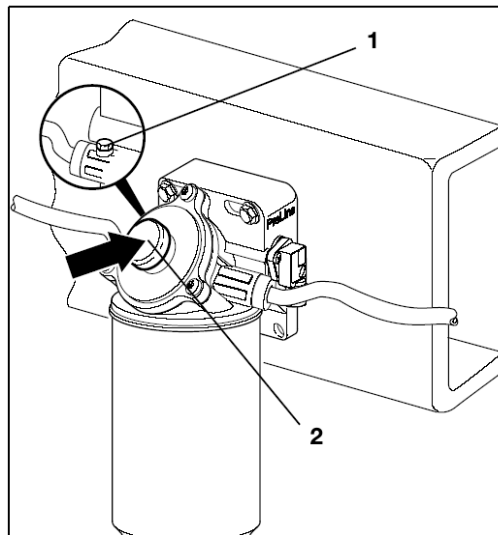

Figure 2-15 Air removal of primary fuel filter

Water draining of filter (figure 2-16):

(Note: Drain the water timely when the water collector is full or the spin-on filter is replaced)

- ① Open the drain plug 2 at the bottom of water collector 1 to drain the water out.
- ② Retighten the drain plug.

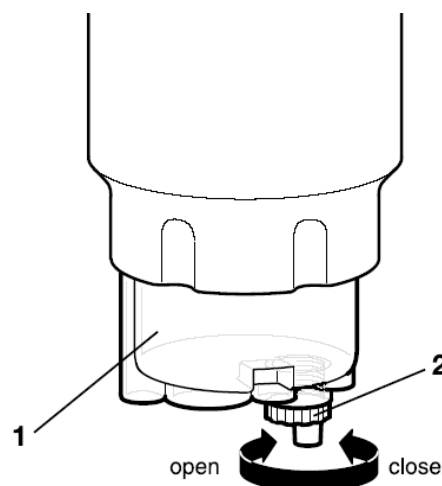

Figure 2-16 check the filter

Steps for replacing water collector (see figure 2-17):

- a. Shut down the engine.
- b. Drain the water from water collector.
- c. Unscrew the bolt of water collector.
- d. Lubricate the seal ring of new collector with oil.
- e. Install the water collector by hand and tighten up with tool.
- f. Check the water collector before it is being used in a new filter.
- g. Install the water collector with a torque wrench (tightening torque: 20Nm).

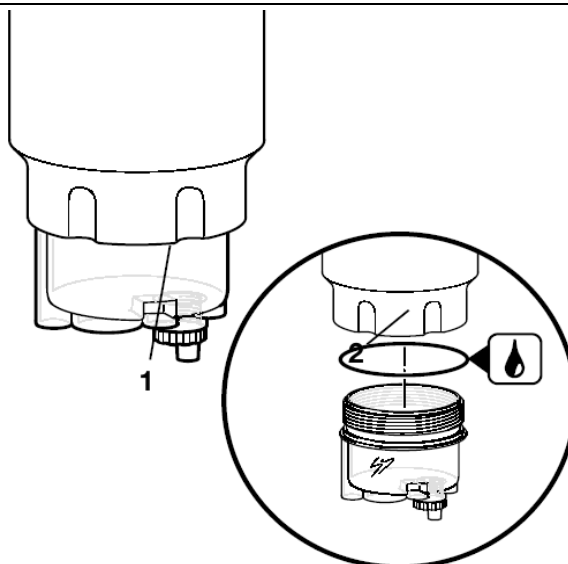
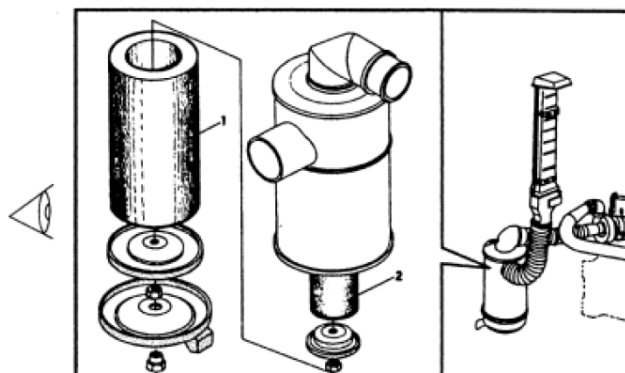

Figure 2-17 Replacement of water collector

- Check intake system

Check the intake hose for aging cracks, and whether the clamp is loose. When necessary, tighten or replace the related part to ensure the tightness of intake system.

- Check the air filter element (figure 2-18)



1.纸质主滤芯 Paper filtering element
2.毛毡安全滤芯 Blanketry safety filtering element

Figure 2-18 Air filter

The maximum permissible intake resistance of the diesel engine is 7kPa. The max intake resistance shall be checked at rated speed and full load, and if the intake resistance reaches the maximum permissible limit, clean or replace the filter element in accordance with requirements of the manufacturer.

CAUTION: it is in no case allowed to run the engine without air filter; otherwise, dust and foreign matters may get into the diesel engine to cause premature engine wear.

Remove the element from the air filter, and tap its end face or blow with compressed air (from the inside out) to clear dust as shown in figure 2-19.

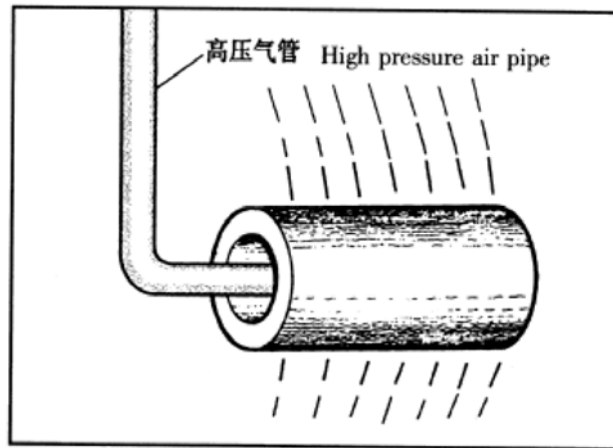

Figure 2-19 Filter element cleaning

CAUTION: Do not damage the filter paper, do not clean the filter paper with water or oil, do not tap or knock the filter element heavily.

- Check urea dosing pump filter element

At the time of maintenance, it's necessary to remove the filter element of urea dosing pump and thoroughly clean with clean water before installation. Do not slap or knock the filter element with high force.

Note: At each replacement or disassembly/installation of urea nozzle, it's necessary to check the status of urea nozzle gasket. In event of damage or deformation, replace the urea nozzle.

- Clean the urea tank and urea tank filter element

At the time of maintenance, it's necessary to check the cleanliness of urea tank and filter element and clean them when necessary.

2.4 Maintenance for Long-Term Storage of Diesel Engine

2.4.1 Clean the diesel engine

- ① Release the engine oil after warming the machine. Clean the engine oil filter and add antirust oil;
- ② Release the fuel and add the antirust oil mixture;
- ③ Drain the water and add the coolant with antirust agent;
- ④ Start the engine and idle running for 15~25 min;
- ⑤ Discharge all the engine oil, fuel, coolant and urea solution;
- ⑥ Take protective measures for other positions.

2.4.2 Protection during storage

Use cap or plastic cloth to seal each oil, air and water inlet and outlet; use VCI film to cover the whole diesel engine.

Note: Outer packing is needed for transportation.

2.4.3 Oil sealing

The oil seal period of diesel engine is one year in general since delivery. If storage exceeds the period, check and perform oil seal again as follows:

- 1) Oil sealing of the parts, components and entire diesel engine shall be performed in a clean environment after removing the rust, oil stain and dust.
- 2) Subject to actual requirements, anti-rust oil may be applied by means of dipping, spraying, coating or filling.
- 3) Locations and requirements:
 - ① Intake and exhaust systems: Make the diesel engine running by using a starter or a driving device and spray JB-1 calibration fluid to the intake pipe port by using air spray gun for at least 15 seconds.
 - ② Turbocharger: Under stationary state or make the diesel engine running by using a driving device, spray JB-1 calibration fluid to the intake/exhaust port of turbocharger by using air spray gun for at least 5 seconds.
 - ③ Air compressor: At idling state or make the diesel engine running by using a driving device, spray JB-1 calibration fluid to the intake port of air compressor by using air spray gun for at least 5 seconds.

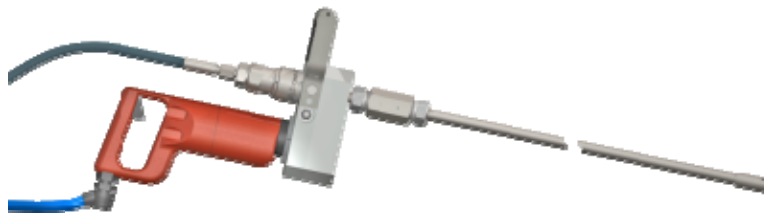

Figure 2-20 Air spray gun

Part III Common Failures and Troubleshooting

The WP12 Euro V series diesel engine is designed and manufactured under a strict quality management system. Each delivered diesel engine has been tested according to specified standards. As the diesel engine is of precision machinery, its lasting good functions are inseparable from the regular maintenance. Generally, failures of diesel engine are often caused by:

- (1) Operation against the regulations, and improper manage and use;
- (2) Failure to perform maintenance in accordance with the requirements, or even replace maintenance with repair;
- (3) Service life of diesel engine can be greatly shortened if spare parts are not well manufactured, especially in case that counterfeit and shoddy products are purchased for sake of saving money;
- (4) Inappropriate or unqualified fuel and oil are used.

3.1 Diagnostic method

Generally, common diagnostic methods for engine failures are as follows:

- (1) Observation: Judge the failure condition by observing failure features such as smoke color of diesel engine (figure 3-1).
- (2) Auscultation: Judge the failure location, feature and extent by listening to the abnormal noise of diesel engine (figure 3-2).



Figure 3-1 Observation



Figure 3-2 Auscultation

- (3) Stop fuel supply to one cylinder: Generally, stop the fuel supply to a certain cylinder in doubt, and compare the working condition of the diesel engine before and after stopping fuel supply to narrow down the scope for finding the failure position or reason further.
- (4) Comparison: Replace a certain assembly or component to determine whether it has failed.

CAUTION:

- (1) The cause for diesel engine failure shall be determined with care. Before the cause is basically understood, do not remove the diesel engine at discretion. Otherwise, the failure cannot be removed, instead, more serious failure will be caused due to improper assembly after disassembly.
- (2) For check and maintenance of the critical components such as high pressure fuel pump, ECU, common rail and turbocharger, special instrument or equipment shall be used by experienced personnel. Users without experience shall not disassemble or adjust them randomly.

3.2 Common failure causes and troubleshooting

3.2.1 Diesel engine cannot be started up

	Causes	Troubleshooting
Starter does not work	1. Whether the gear lever is at neutral gear.	Ensure that the gear lever is at neutral gear.
	2. The off-vehicle shutdown switch of the vehicle is switched on.	Maintain the shutdown switch disconnected.
	3. The neutral position gear is damaged or the wiring connection is poor.	Try the emergency starting (to press down the ignition switch continuously for at least 5s).
	4. The battery voltage is excessively low.	Measure with a diagnostic scanner the actual "battery voltage", which shall be normally 24V.
	5. The starter relay and wiring are loose or fractured.	Check if the oxide on the surface is excessive and if the bolt on the surface of terminal is loose or fractured.
	6. Starter is burnt out.	Check if the starter relay is normal with a multimeter.
	7. The ignition switch or start switch is damaged.	Turn the ignition key to ON and see if the panel lamp is on. Turn the ignition key to START and see if the starter acts.
The rail pressure cannot be built up (the starter works normally, but the engine cannot be started)	1. The fuel tank level is excessively low.	Add fuel.
	2. The hand operated fuel supply pump does not work properly.	Operate the hand operated fuel supply pump to see if it works properly.
	3. There is air in low-pressure fuel passage.	Check for and discharge any air in the low-pressure fuel passage.
	4. The high-pressure fuel passage is leaky.	Check if the high-pressure fuel pipe connection nut is loose, and tighten it if necessary.
	5. The fuel passage is blocked.	Check if the diesel filter is blocked. It is recommended to timely replace the diesel filter.
	6. The rail pressure sensor is damaged or the voltage is abnormal.	Check if the initial voltage of rail pressure sensor is around 500mV, or if the preset rail pressure is in range of 30-50MPa.
	7. The flow metering unit is poorly connected or damaged.	Check if the flow metering unit is in good condition. Pull out the flow metering unit connector and try to start again.
The wiring harness is broken or short-circuited.	1. The harnesses of the engine or the vehicle are not well-connected, or are broken or short-circuited.	Check the installation of the connectors. Check the make-and-break of circuits with a multimeter (better with a circuit tester) according to the pointer definition of the circuit diagram.
Signals of crankshaft and camshaft are lost.	1. The sensor is damaged, or the harnesses are broken or short-circuited.	Check if the sensor is damaged, and if the harnesses are well-connected.
	2. The sensor is not fixed reliably, causing the clearance between the sensor and the	Check the clearance between the sensor and the sensing teeth, which shall be normally 1mm±0.5

	sensing teeth to be excessively large or small.	mm.
--	---	-----

3.2.2 The engine is difficult to start up

Causes	Troubleshooting
1. The diesel engine is not used for a long time.	The fuel return pipe should be placed below the diesel fuel level.
2. There is little air in the low-pressure piping.	Check the tightness of fuel pipe and connection, and confirm if the venting screw is tightened, and discharge any air in the fuel pipe.
3. The signals of crankshaft speed and camshaft speed are too weak, and it takes a long time to judge if they are synchronized.	Find out the causes and readjust it.
4. The ambient temperature is excessively low and the preheater is out of service.	Check if the heating flange is properly wired or replace the preheater.
5. The quality of diesel fuel and oil is sub-standard.	Replace them with standard petroleum products.
6. The teeth of starter or flywheel ring gear are being collided.	Replace the starter and flywheel ring gear.
7. Piston ring or cylinder liner are worn out or valve is not sealed tightly.	Replace any affected piston ring, cylinder liner, valve seat or valve.
8. The exhaust brake butterfly valve is stuck in closed position, causing unsmooth exhaust.	Replace the butterfly valve.

3.2.3 Insufficient engine power

	Causes	Troubleshooting
The injector is faulty	1. There is mechanical failure in the fuel injector: the needle valve is stuck.	Check the air filter and air inlet pipe, and clean or replace the filter element.
	2. There is wiring failure in the fuel injector.	Check the wiring of fuel injector. Make sure that the connection is not broken or nor directly shorted to ground through the cylinder head.
The water temperature is excessively high	1. The water level in water tank is excessively low.	Check if the tank is leaky and add water if necessary.
	2. The fan speed is excessively low or it does not run.	Check the fan rotating element.
	3. The water tank is blocked.	Check the water tank, and clean or repair it if necessary.
	4. The water pump belt is loose.	Adjust the tension of belt as per specifications.
	5. The water pump gasket is damaged, or the water pump impeller is worn out.	Check and repair or replace them.
	6. The thermostat is faulty.	Replace the thermostat.

	7. The water pipe sealing element is damaged, and there is air in the pipe.	Check the water pipe, connection, gasket, etc. and replace any damaged parts.
The oil temperature is excessively high	1. The oil level in oil pan is excessively low or the oil pan is in shortage.	Check the oil level and find out the leaking points, and repair them and then add oil.
	2. The water temperature is high.	Find out the causes for excessively high water temperature and eliminate them.
	3. The liquid is not flowing through the oil cooler smoothly.	Check and clean the oil cooler.
The intake temperature is excessively high	1. The intake temperature is excessively high.	Check the heat-sinking capability of intercooler.
The synchronizing signal is erroneous	1. The sensor signal is invalid.	Read the blink code with the blink code lamp. Look up the blink code table for causes and eliminate them.
Flow metering unit is faulty	1. The flow metering unit is faulty.	Check the circuits to see if the flow metering unit or rail pressure sensor is faulty, and request our agency to handle it.
Abnormal fluctuation in rail pressure caused by leakage in fuel piping	1. The rail pressure fluctuates abnormally and the vehicle speed is unsteady.	First switch off the power supply, wait for 1min and then restart the engine. If the failure remains, then check the tightness of fuel piping and remove any failure therein.
Sensor failure	1. There is failure in the intake pressure sensor, water temperature sensor or rail pressure sensor.	Check the intake temperature and pressure sensor, water temperature sensor and rail pressure sensor, and check if the connectors are reliable.

3.2.4 The engine always runs at 1000r/min

Causes	Troubleshooting
1. The electronic accelerator cable is loose or wrongly wired.	Pull and plug the accelerator cable again or check if it is correctly wired, and then rewire it.
2. Water enters into the electronic accelerator connector.	Blow-dry the connector with tools and restart the engine.

3.2.5 Engine idling speed unstable

Causes	Troubleshooting
1. Malfunction of fuel injectors	Check the fuel injector and harness for each cylinder.
2. For vehicle provided with speed sensor, there is speed signal input when the vehicle is not moving.	Check the odometer and speed sensor signals and wiring.
3. The fuel quality is poor or there is water or wax in the fuel.	Clean the fuel system and replace the fuel filter.
4. The fuel injection nozzles atomize	Check and repair them.

fuel unstably.	
----------------	--

3.3 After treatment system failure diagnosis and troubleshooting

3.3.1 Failure analysis of after treatment system component

3.3.1.1 Urea dosing pump fault

For the urea pump there are mechanical and electrical faults. The electrical faults generally are those of the components (urea pump motor, urea pressure sensor, directional valve, and urea pump heating wire) related to the 12-port connector. The mechanical fault includes the urea pump clogging and the urea pump pressure build up failure due to mechanical factor. The structure of urea pump is shown in figure 3-3.

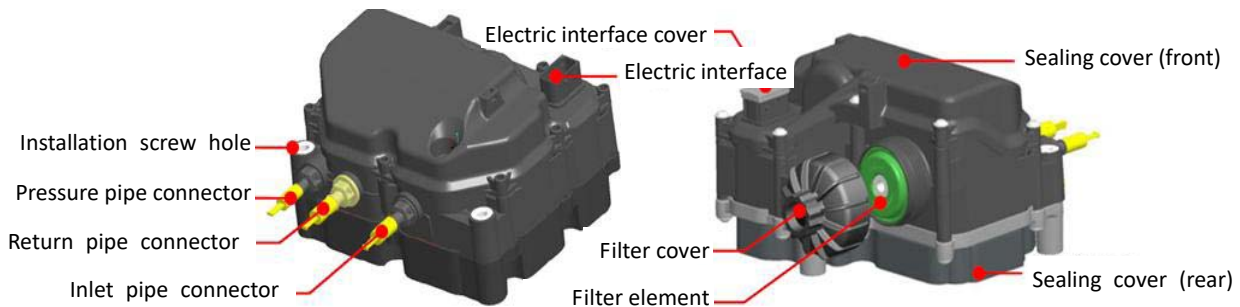

Figure 3-3 Urea dosing pump

a) The urea dosing pump cannot build up pressure normally

Fault symptom: the Malfunction Indicator Light (MIL) is normally on; the urea dosing pump stops after working for a while; the urea solution is not consumed.

Possible causes:

- 1) Serious air leakage of urea solution inlet pipe;
- 2) Urea solution leaks from inlet pipe;
- 3) The urea solution inlet and return pipes are reversely connected.
- 4) The urea solution inlet pipe is seriously bent.

Troubleshooting:

Check whether the urea solution suction pipe is firmly connected and whether the suction pipe and the fluid return pipe are reversely connected.

b) The temperature of urea dosing pump is abnormal

Fault symptom: the MIL is normally on; great difference with the environment temperature, the after treatment system cannot work normally.

Possible causes:

- 1) The urea dosing pump power supply terminal is open-circuited.
- 2) The urea dosing pump controller terminal is open-circuited.

The connection of urea dosing pump and ECU is shown in figure 3-4.

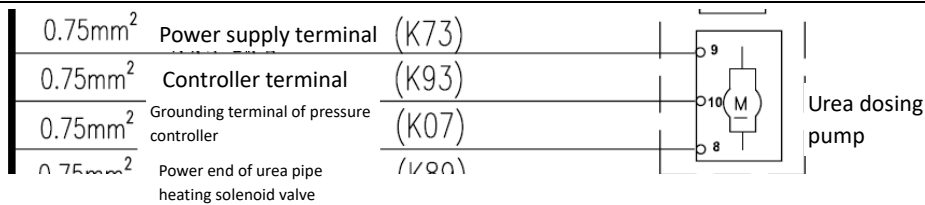

Figure 3-4 picture of electricity

Troubleshooting:

Check the pins of urea dosing pump and whether the connector terminal is improperly inserted.

c) Urea solution injection pressure drop error

Fault symptom: the MIL is normally on; the urea dosing pump stops after working for a while; the urea solution is not injected; the after treatment system cannot work normally.

Possible causes:

The urea solution pressure pipe is blocked.

Troubleshooting:

Remove the urea solution pipe and clean it with water to eliminate the fault. Do not bend the pipe during assembling.

d) The actuation high end of urea solution reversing valve is open-circuited

Fault symptom: the MIL is normally on, the urea solution is not consumed.

Fault mechanism: the urea solution reversing valve is designed in the 12-port connector of urea dosing pump and controlled by EDC17, its function is to prevent the urea solution residue in the pipe and pump. Every time after the engine flameout, the reversing valve works and suck the urea solution in the pipe back to the urea solution tank in 90 seconds. The possibility of several faults of a connector is very high, for example, pin comes out because of loosened lock plate or water enters the connector.

Possible causes:

- 1) Connector loosened or pin comes out;
- 2) Water enters the connector;
- 3) Related harness fault.

Troubleshooting:

- 1) Check the urea dosing pump connector;
- 2) Whether one or some pins of connector come out.

e) SCR urea solution pressure buildup error

Fault symptom: every time after running the vehicle for several minutes to dozens of minutes, the MIL is normally on, the flash code 441 (SCR urea solution pressure buildup error) will be reported, and the urea solution is not consumed.

Fault mechanism: Before injecting urea solution, the urea dosing pump will build up 9bar pressure, and inspect

the pressure via the pressure sensor in the urea dosing pump. When the engine is started, the urea dosing pump tries several times to build the urea solution pressure, if the pressure cannot reach 9bar, this fault will be reported. This fault is generally caused by: too little urea solution, reverse connection of urea solution pipes, suction pipe blockage or leakage, leakage from pressure pipe; it is rarely due to urea dosing pump fault.

Possible causes:

- 1) Too little urea solution;
- 2) The suction pipes are wrongly connected, blocked or leak air;
- 3) The pressure pipe leaks;
- 4) The urea dosing pump is blocked or mechanical fault of urea dosing pump.

Measures and steps:

- 1) Check whether the urea solution level is proper;
- 2) Check whether the urea solution pipes are wrongly or reversely connected;
- 3) Check whether the suction pipe is bent or blocked;
- 4) Check the suction pipe and pressure pipe for leakage;
- 5) If no problem is detected in the above steps, check whether the urea dosing pump joint is obviously blocked.

3.3.1.2 Urea solution tank failure

The urea solution tank mainly includes the tank housing and level/temperature sensor assembly. Sensor faults easily occur, and the common faults include: incorrect level indication, abnormal temperature display, MIL normally on and level/temperature sensor fault. These faults are mainly caused by: sensor damage, sensor connector not firmly connected or short circuit, and related harness faults. Sometimes, if the level/temperature sensor is not matched with the electric parameters required by Weichai, for example, the customer buys the urea solution tank and did not notify Weichai, this may cause abnormal urea solution level or temperature, even sensor fault is reported.

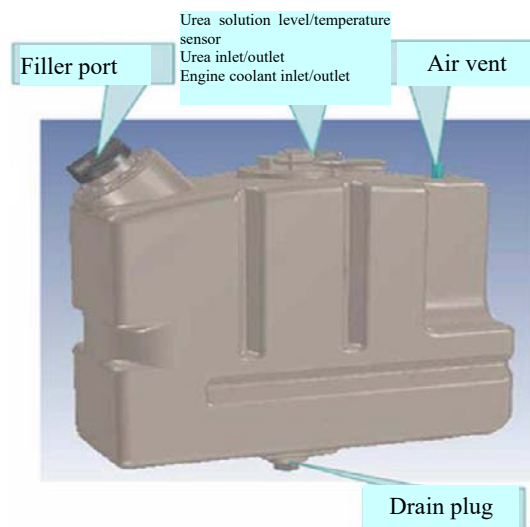

Figure 3-5 Urea solution tank

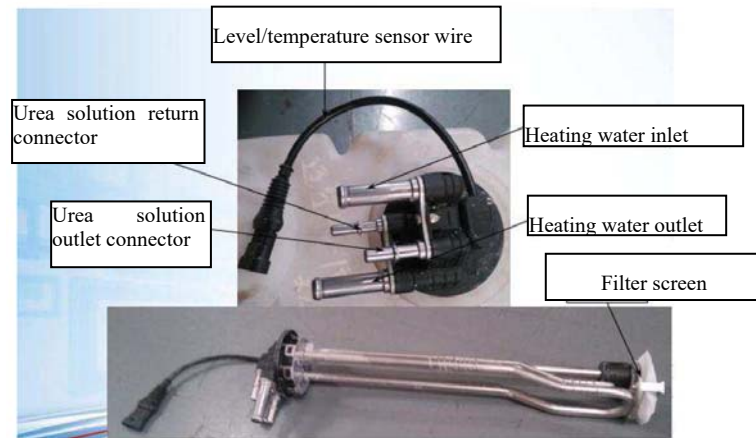

Figure 3-6 Urea solution tank connection

a) Urea solution level sensor voltage higher than the upper limit

Fault symptom: MIL is normally on, the flash code 445 (Urea solution level sensor voltage exceeds the upper limit) is reported, and the urea solution level indicated on the instrument is incorrect.

Fault mechanism: If this fault does not exist before the vehicle delivery and it appears after the vehicle traveling for a period of time, this is generally caused by open circuit of sensor harness or connector. Please inspect whether the 1# pin (ECU pin K57) of sensor connector is open-circuited or shorted to power supply. If the fault cannot be eliminated, further check other pins and harnesses for faults.

Possible causes:

- 1) The pin of sensor connector or vehicle harness connector is loosened;
- 2) The harness open circuit or not firmly connected;
- 3) Pin K57 shorted to power supply;
- 4) Sensor damage or sensor parameter not matched with the Weichai's requirements.

Measures and steps:

- 1) Check the places with highest failure rate: sensor connector and harness;
- 2) Check the pins after unplugging the sensor connector;
- 3) Retighten the pins.

b) Abnormal urea solution level/temperature display

Fault symptom: The urea solution level display is incorrect (for example, when the urea solution is insufficient, the instrument displays that the urea solution is 100%), the difference between urea solution temperature and current environment temperature is great, and the related sensor fault is not reported.

Fault mechanism: Such fault is generally because that the urea solution tank sensor is not the kind specified by Weichai or the vehicle urea solution tank is replaced recently but the model of sensor in the tank is different from that mounted on the vehicle before delivery. The electric parameters of the sensor are different, and causing mismatched data calibration and wrong level/temperature display.

Possible causes:

- 1) The customer replaced the urea solution tank by the kind which is different from the original tank;
- 2) When matching with the vehicle, the urea solution tank is self-purchased but not notified the Weichai technician for data recalibration;
- 3) Sensor or related harness damage, causing the change of electric parameters (this possibility is minor), but the sensor related fault is not reported.

Measures and steps:

- 1) Check the urea solution tank and sensor and whether the urea solution tank is same to the original tank on the vehicle;
- 2) Check whether the urea solution tanks are from different manufacturers.

c) Abnormal urea solution level/temperature display.**Fault symptom:**

The urea solution level/temperature display is incorrect: when there is very small amount of urea solution, the instrument displays that the urea solution level is 100%; the environment temperature measured by EOL is 21°C, but the urea solution tank temperature reaches 42°C, this is obvious inconsistency. No other fault of urea solution level sensor.

Fault mechanism: Such fault is generally because that the urea solution tank is inconsistent with the product specified by Weichai; or, in special circumstances may due to excessive circuit resistance, excessive resistance in ECU or other electric faults.

Possible causes:

- 1) The urea solution tank is inconsistent with the product specified by Weichai;
- 2) Excessive resistance of sensor related harness;
- 3) Excessive resistance between two ends of ECU sensor pins.

Measures and steps:

- 1) Check the urea solution tank and sensor to verify whether the urea solution tank is the kind specified by Weichai;
- 2) If the urea solution tank is normal, please check the sensor harness; power on and check whether the resistance is normal;
- 3) Measure the resistance between K57 and K52, K80 and K64 of ECU urea solution level/temperature sensor;
- 4) If the internal resistances of pins are all 3.675kΩ, the ECU is of new, it is needed to check whether the data is conform to the new ECU.

3.3.1.3 Heating element fault

The freezing point of urea solution is -11.5°C, when the system works at low temperature, the urea solution will freeze, causing the system inoperative. Therefore, the urea solution tank needs unfreezing. The urea solution tank uses the engine coolant for unfreezing and heating. The flow direction of heating coolant route is shown in the figure below.

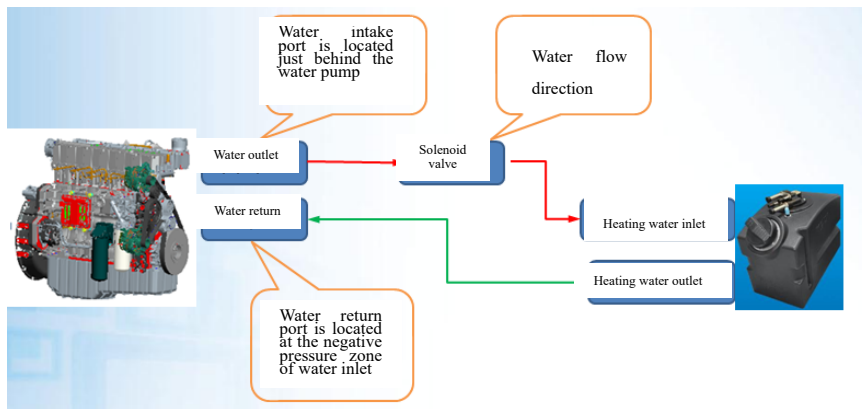

Figure 3-7 Flow direction of heating water

The heating system includes the water heating system and electric heating system. As there are many relays (a total of 5 relays for heating resistance wires: pump to tank relay, pump to nozzle relay, tank to pump relay, urea dosing pump relay and main heating relay), harnesses and resistance wires, the failure rate of electric heating system is relatively high, mainly shown by relay damage, open circuit of resistance wires, open/short circuit of harness, etc.

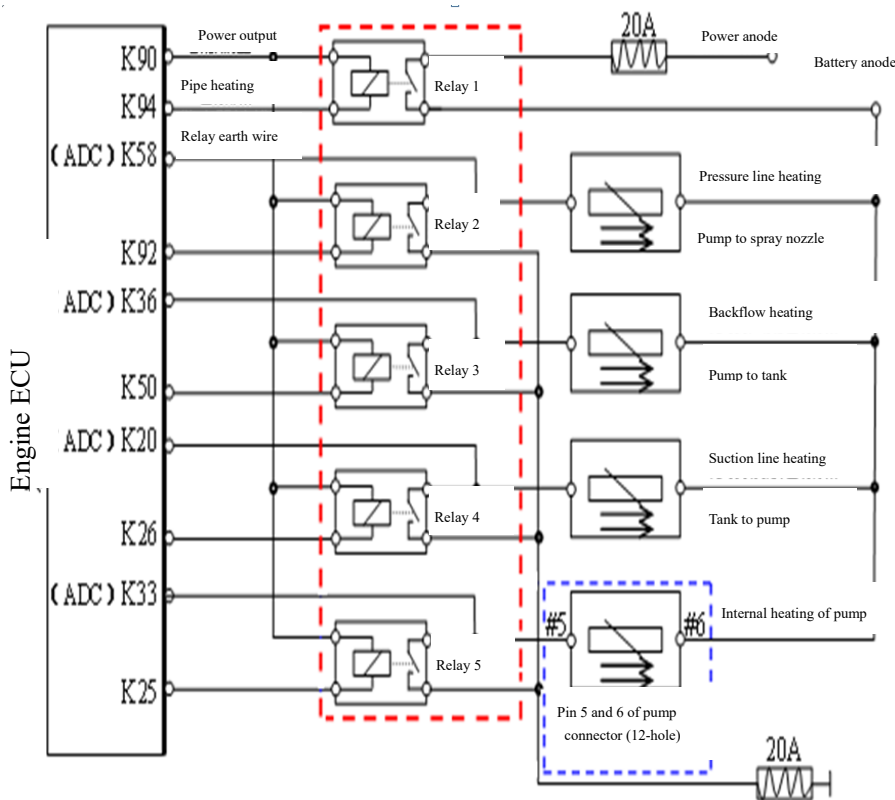

Figure 3-8 Circuit diagram of reduction agent heating system

Fault detection of heating resistance wires relay: first, relay 1 circuit closed (K94 becomes 0V), the other relays remain disconnected (pin voltage should be controlled to 24V, the same with that of K90). In normal conditions, the voltage of K58, K36, K20 or K33 is about 24V. If the measured voltage of one pipeline is abnormal, “heating resistance wires no load” or “heating resistance wires short circuit” will be reported. Then, all heating resistance wires, K58, K36, K20 and K33 should be checked for open circuit and short circuit.

Relay fault detection: the ECU can detect whether the relay is correctly installed, it will report the “open/short

circuit of heater relay” fault if a relay is neglected during installation, damaged or there is circuit fault. In such case, please check whether the related relay, harness and connector are normal.

The water heater faults are mainly: water heater solenoid valve harness/connector faults; mechanical fault (wear, sticking) of water heater solenoid valve that may lead to urea solution tank heating failure or too low temperature of DEF tank or lead to continuous heating of urea solution tank and causing too high temperature of urea solution and volatilization, thus the emission of the engine will fail to meet the standard; water heating pipe bending and blockage, leakage from or blockage of pipe and connecting port that may cause heating failure or coolant leakage.

a) Excessive heating of urea solution tank

Fault symptom: After running for a period of time, the flash code lamp and the MIL are normally on and the fault 446 (urea solution tank over heating) is reported.

Fault mechanism: The urea solution tank is heated through the engine coolant and the water heater solenoid valve is controlled by EDC17. As the urea solution is highly volatile at 75°C, the temperature of urea solution tank shall not be too high. If the water heater solenoid valve cannot be turned off normally, the engine coolant may continue heat the urea solution tank, causing too high temperature of urea solution tank and the fault will be reported; for the other causes of high urea solution tank temperature, the fault will also be reported.

Possible causes:

- 1) The urea solution tank water heater solenoid valve is stuck at the normally on status;
- 2) The urea solution tank temperature sensor fault.

Measures and steps:

- 1) Check the actual temperature of urea solution tank to determine the validity of temperature sensor;
- 2) Check the urea tank water heater solenoid valve and the switch status.

b) Open circuit of urea pipe heater relay

Fault symptom: MIL is normally on and fault of main urea heater relay open circuit, pipe heater relay or pump heater relay is reported.

Fault mechanism: Relay 1 is of main urea heater relay, relay 2, 3 and 4 are of pipe heater relay and relay 5 is of pump heater relay. If the heater relay is neglected during installation or the circuit is damaged, the open circuit fault will be reported.

Possible causes:

- 1) Relay neglected during installation;
- 2) Relay harness or connector fault.

Measures and steps:

- 1) Check the relay installation;
- 2) Correctly install the relay.

c) Open circuit of urea pipe heating resistance wires

Fault symptom: MIL is normally on and faults of open circuit of urea pipe heating resistance wires and urea dosing pump resistance wires are reported.

Fault mechanism: if the urea pipe and urea dosing pump only connected with heater relay but not connected with the resistance wires or the resistance wires are not connected completely according to the pin diagram, the ECU can also detect the fault.

Possible causes:

- 1) The resistance wires are neglected during installation;
- 2) K58, K36, K20 and K33 are not connected according to the pin diagram or there is the fault of open circuit;
- 3) Other wires not connected completely according to the pin diagram.

Measures and steps:

- 1) Check whether the resistance wires are installed;
- 2) Correctly connect the resistance wires and check and confirm the correct connection of K58, K36, K20 and K33.

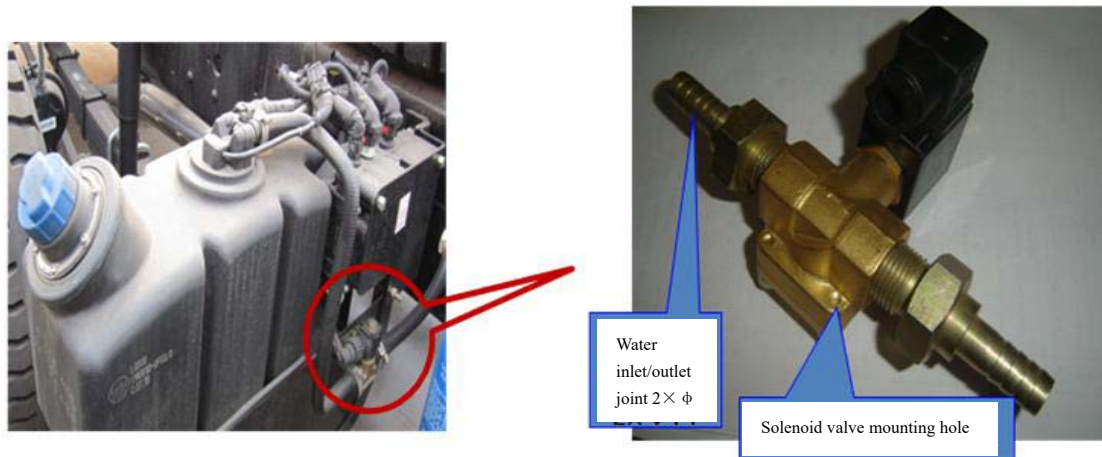

Figure 3-9 Urea heating pump

3.3.1.4 Urea dosing module fault

The structure of urea dosing module is relatively simple, and the involved faults are typical.

The faults mainly include:

Spray nozzle solenoid valve faults: Connector or harness damage, causing open/short circuit; solenoid valve coil burnt and this can be judged by measuring the resistance.

Spray nozzle mechanical fault: Poor urea quality or nozzle aging, causing the nozzle wear and higher urea consumption; nozzle blockage because of urea crystals or other PM; or nozzle deformation or crack due to other reasons. The above faults affecting the urea injection and emissions may limit the engine torque.

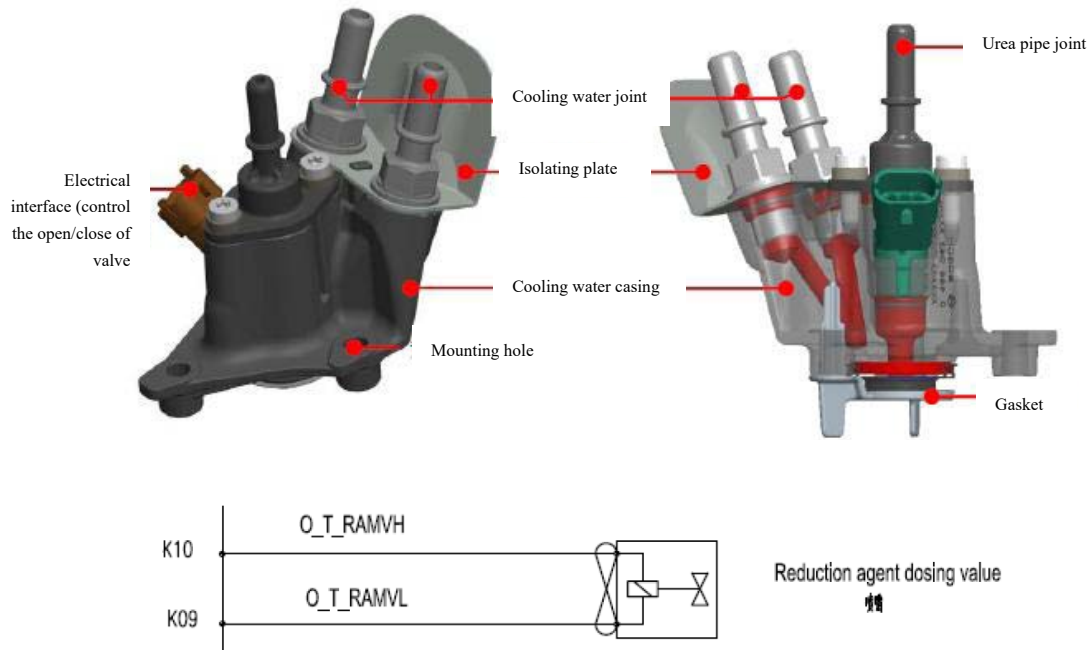

Figure 3-10 Urea dosing module

a) Urea dosing module drive high end shorted to power supply

Fault symptom: MIL is normally on, and the fault 453 (SCR urea dosing module drive high end shorted to power supply) is reported.

Fault mechanism: the urea dosing module solenoid valve has 2 pins: K09 and K10 correspond to connector numbers 2 and 1, the K10 pin is the solenoid valve drive high end and K09 pin is the drive low end. This fault indicates that the K10 pin is shorted to power supply, please check the connector K10 and harness.

Possible causes:

- 1) Connector fault, causing the K10 pin shorted to power supply;
- 2) K10 pin related harness fault, causing short circuit to external power supply.

Measures and steps:

- 1) Check the dosing module connector for damage or short circuit;
- 2) Measure the voltage of K10 pin;
- 3) Check the vehicle harness connector.

b) High urea consumption

Fault symptom: The urea consumption is high, the ratio to fuel consumption is far higher than 1/20. No other related fault.

Fault mechanism: If there is no fault reported, it indicates that the harness and electric parts of after treatment system are basically normal.

Possible causes: leakage from urea pipeline, pump or tank, urea spray nozzle wear, causing the urea leaks from the nozzle.

Possible causes:

Urea leakage from pipeline and related electric parts;

Spray nozzle wear, causing the increase of urea injection amount.

Measures and steps:

- 1) Check the urea tank, pump and pipeline for leakage;
- 2) If there is no urea leakage, start the vehicle and run it at higher power, so that the exhaust temperature can reach the lowest temperature 200°C for pressure buildup of urea dosing pump pressure until the EOL detects that the urea dosing pump pressure is stable at 9bar;
- 3) Do not stop the engine, keep the engine idling;
- 4) Take out the urea spray nozzle from the exhaust pipe to observe the nozzle for leakage.

3.3.1.5 Low SCR conversion efficiency and exhaust manifold fault

SCR carrier and SCR catalyst are designed in the SCR box, and if faults occur, the emission may not meet the standard and the engine torque may be limited.

The faults mainly as the following:

Catalyst failure: as the SCR box is impacted or polluted or covered by other matters (particulates in the black smoke), the catalytic reduction efficiency will be reduced, finally leading to emission fails to meet the standard and engine torque be limited;

SCR box blocked: SCR box deformation or blockage due to other reasons, causing high exhaust backpressure, or in serious cases, faults including black smoke, engine speed trembling and powerless, thus affecting emission.

Exhaust pipe corrosion: The urea solution is corrosive, it is recommended that the exhaust pipe should be made of stainless steel with smooth internal surface, and to minimize welding of the pipe to avoid exhaust pipe corrosion due to urea residue.

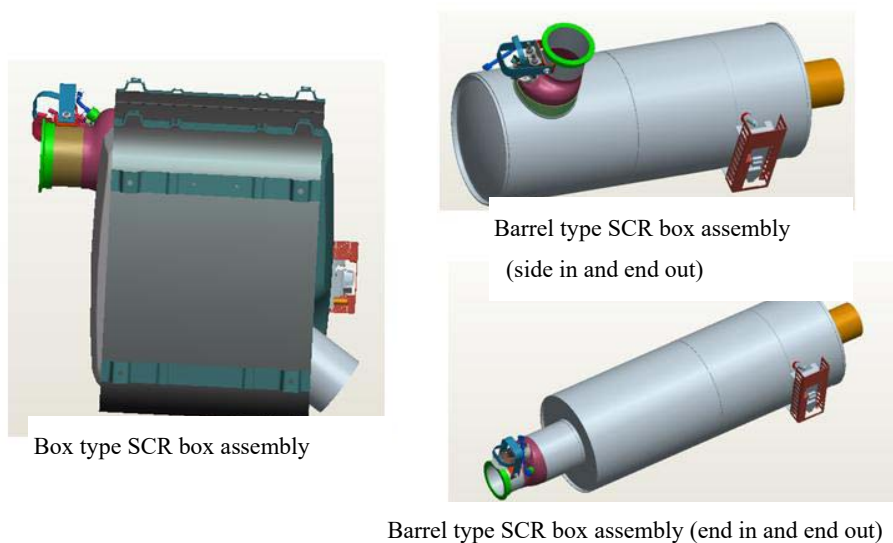

Figure 3-11 SCR box assembly

a) Exhaust pipe rust and corrosion

Fault symptom: Exhaust pipe damaged due to corrosion only about 1 month. Still the case after replacing the

exhaust pipe.

Fault mechanism: The urea solution is corrosive, it is required that the exhaust pipe downstream the urea spray nozzle should be made of stainless steel with smooth internal surface, and to minimize welding of the pipe to avoid exhaust pipe corrosion due to urea residue.

Possible causes:

- 1) Exhaust pipe material is not qualified with poor anti-corrosion resistance;
- 2) Exhaust pipe inner surface is rough, causing residue of urea crystals;
- 3) There are welding marks inside the exhaust pipe;
- 4) Exhaust pipe has many joints.

Measures and steps:

- 1) Check the processing of engine exhaust pipe;
- 2) Check the material of exhaust pipe;
- 3) Replace the exhaust pipe if necessary.

b) Actual average conversion efficiency of SCR box lowers than the threshold 1(threshold 2)

Fault symptom: MIL is normally on; normal urea injection; and no other related fault.

Fault mechanism: These two faults indicate that the NO_x concentration in exhaust gas is high and exceeds the regulatory requirements. If not repaired timely, it may lead to engine torque limited.

Possible causes:

- 1) Engine original emission deterioration: At the upstream of after treatment system, the exhaust gas from the turbocharger is very bad;
- 2) SCR box assembly deterioration, causing low conversion efficiency;
- 3) Larger urea injection error: the actual injection amount is less than the set value;
- 4) Poor fuel quality.

Measures and steps:

- 1) First, check and judge whether the engine original emission is seriously deteriorated, for example, serious black smoke;
- 2) Check whether the fuel is qualified;
- 3) Check whether the urea spray nozzle is blocked or leaks, which causes incorrect control of injection amount;
- 4) Check the SCR box assembly for aging or crystals or be covered or blocked by soot.

3.3.1.6 Urea pipe fault

The after treatment system includes 3 sections of urea pipe and 3 types of faults easily occur: pipe blockage, pipe leakage and pipe bending.

Pipe blockage: generally caused by urea crystallization or poor urea quality, which affects the urea injection and pressure build-up, leading to the emission fails to meet the standard;

Pipe leakage: mainly caused by the pipe joints is improper or poor tightness of joint and pipe aging or wear.

Pipe bending: pipe bending will cause urea pressure build-up failure or injection fault, leading to emission fails to meet the standard.

a) Urea pressure build-up error of SCR

Fault symptom: MIL is normally on; NO_x emission fails to meet the standard; urea cannot be injected normally.

Fault mechanism: when the exhaust pipe temperature reaches the lowest temperature for pressure build-up, the urea dosing pump starts to build up the pressure and check all urea pipes, urea dosing pump and nozzles for leakage or blockage. If the urea pressure cannot reach 9bar in a very long time, the ECU will determine that there may be urea leakage and reports the fault, and then the after treatment system stops working.

Possible causes:

- 1) The urea pipes are wrongly connected or there is urea leakage from the suction pipe;
- 2) Leakage from the pressure pipe;
- 3) Urea dosing pump fault.

Measures and steps:

- 1) Check the suction pipe for wrong connection, leakage or bending;
- 2) Check whether there is leakage from the pressure pipe;
- 3) Check the joint tightness between pressure pipe and urea dosing pump.

b) SCR not drained completely after previous driving cycle

Fault symptom: after the T15 is powered on; the MIL and flash code lamp are normally on; read the flash code 447 (indicates the SCR is not drained completely after previous driving cycle), there is no such fault before.

Fault mechanism: to avoid urea crystallizing in the pipe and pump which may cause urea pipe blockage or pump damage, it is required that do not turn off the vehicle switch within 90 seconds after stopping the vehicle. In this 90 seconds, the urea dosing pump will continues working and the urea in the pipe and pump will be sucked back into the urea tank. This fault will occur if the driver does not operate according to the requirement, for example, turn off the vehicle switch too early.

Possible causes:

Violation operation of driver.

Measures and steps:

- 1) Ask the driver whether the vehicle switch is turned off 90 seconds after stop of previous driving;
- 2) The driver turned off the vehicle switch too early and the waiting time did not reach 90 seconds;
- 3) Restart, after stop of next driving cycle, the driver shall operate correctly and turn off the vehicle switch after waiting for 90 seconds.

3.3.1.7 Faults of after treatment system related sensors

The sensors mainly include the upstream exhaust gas temperature sensor, the environment temperature sensor and the NO_x sensor.

Upstream exhaust gas temperature sensor and environment temperature sensors

There are mainly two types of faults:

- 1) The sensor voltage signal above the upper limit or below the lower limit. If it exceeds the upper limit, the cause is generally that the harness or connector is open-circuited or shorted to power supply; if it is below the lower limit, the cause is generally that the harness or connector is shorted to ground.
- 2) Incorrect temperature indication. In such case, the sensor may not be properly installed, the installation position may be improper, or the sensor may be damaged.

When the environment temperature sensor fails, urea heating function will be affected, and causing urea crystallizing or urea dosing pump blockage. When fault of upstream exhaust gas temperature sensor occurs, it will cause urea injection control failure, diesel injection control failure, and exhaust gas emission failing to meet the standard, etc. In brief, if the faults causing the emission failing to meet the standard are not eliminated timely, they will lead to the engine torque is limited.

When the NO_x sensor fails, the measured NO_x concentration cannot be sent to EDC17 via the AT101 message, and the "AT101 message timeout" fault will be reported. This fault is generally caused by wire problems: the NO_x sensor has 4 wires connected with the vehicle harness, they respectively are the power positive, power negative, communication CAN low, and communication CAN high. Please check whether the voltages of 4 wires harnesses and connector are normal and whether there is open/short circuit fault of harness and connector. If the harness and connector are normal, the NO_x sensor may be damaged, please replace the NO_x sensor for verification.

a) Voltage signal of SCR catalyst upstream exhaust gas temperature sensor exceeds the upper limit

Fault symptom: the MIL and flash code lamp are normally on; the fault that the voltage signal of upstream temperature sensor exceeds the upper limit is reported; Measure the upstream exhaust gas temperature by using EOL and the reading is obviously incorrect and does not change.

Fault mechanism: Upstream exhaust gas temperature sensor and related circuit or connector faults, causing the sensor open-circuited. When this fault is detected, the upstream exhaust gas temperature measured by EOL is the default value.

Possible causes:

- 1) Upstream exhaust gas temperature sensor connector or circuit opened;
- 2) Sensor aging or damage;
- 3) Sensor ECU connector circuit fault, causing the sensor open-circuited.

Measures and steps:

- 1) Check the upstream exhaust gas temperature sensor connector;
- 2) Check whether the sensor harness is normally conductive.

b) Unbelievable environment temperature signal

Fault symptom: After the vehicle running for a period of time, the MIL and flash code lamp are normally on; the fault of flash code 235 (environment temperature signal is unbelievable) will be reported.

Fault mechanism: The environment temperature sensor is used for measuring the current atmosphere

temperature. If the ECU detects that the environment temperatures are obviously inconsistent, such as too high or too low, this fault will be reported. The cause of this fault is generally: wrong installation position of environment temperature sensor, for example, installed in the engine compartment, too close to the heat source, abnormal sensor circuit resistance, or sensor fault.

Possible causes:

- 1) Wrong installation position of environment temperature sensor;
- 2) Excessive sensor circuit resistance;
- 3) Environment temperature sensor damage.

Measures and steps:

- 1) Check whether the installation position of the environment temperature sensor meets the requirement;
- 2) Check whether the sensor is close to the heat source;
- 3) Adjust the installation position of the environment temperature sensor as required.

c) Error of CAN receiving frame AT101 timeout

Fault symptom: flash code light and MIL are normally on; the 421error (CAN receiving frame AT101 timeout) is reported.

Fault mechanism: after the NO_x concentration sensor measuring the NO_x concentration, the measured results are sent to the ECU through the AT101 message in the CAN bus; if the ECU cannot receive the AT101 message, this fault will be reported.

Possible causes:

- 1) NO_x sensor wire fault, causing the AT101 cannot be sent out;
- 2) The NO_x sensor is damaged;
- 3) CAN bus network fault.

Measures and steps:

Voltages of 4 pins (No.1, 2, 3, 4) in NO_x sensor shall be respectively 24V, 0V, 2.2V and 2.8V, determine whether there is fault of wrong connection or open/short circuit.

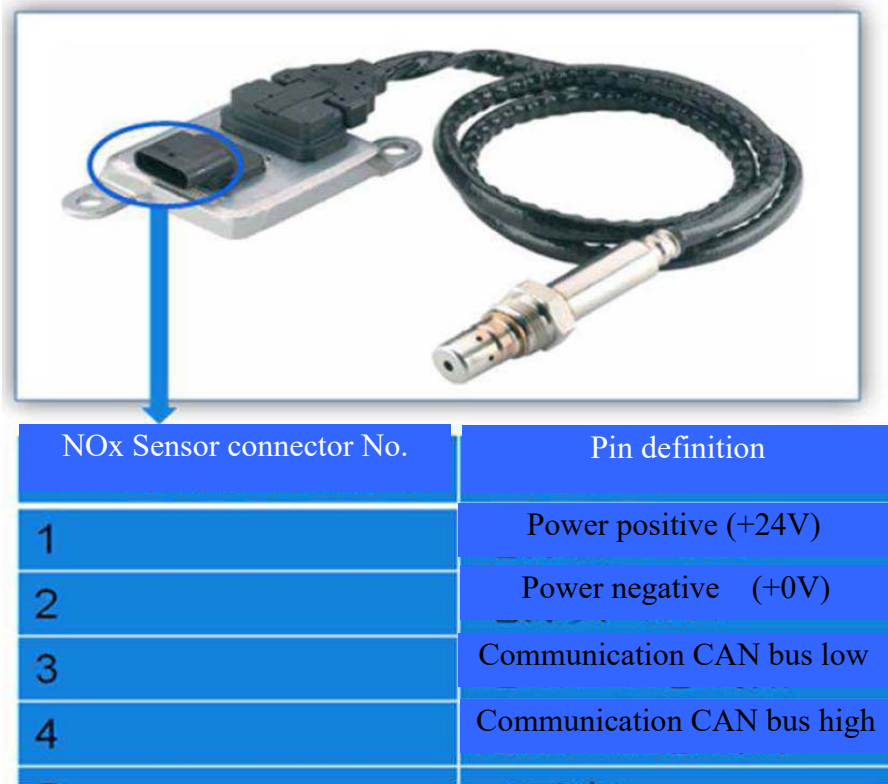

Figure 3-12 NO_x sensor assembly

3.3.1.8 Summary of after treatment system fault

If the SCR system is inoperative, the reasons generally may be:

- 1) Urea pipe leakage or pipe blocked by crystals;
- 2) Urea pipe joint loosened, causing gas leakage but no urea leakage;
- 3) The urea injection pipe and return pipe are reversely connected;
- 4) The urea dosing pump harness connector may be shorted or open or wrongly connected;
- 5) The installation position of SCR system on the vehicle is improper, causing urea pipe bending or short circuit due to water entering;
- 6) The exhaust gas temperature sensor is not connected or open-circuited or wrongly connected;
- 7) The urea tank temperature sensor is abnormal, causing the SCR system in the stop status;
- 8) ECU or ECU harness problem, the pins of ECU connector or sensor connector are loosened;
- 9) Urea resistance wires fuse is burnt, the OL fault related to heating is reported;
- 10) Faults of parts including nozzle, exhaust gas temperature sensor and urea level sensor.

3.3.2 Fault diagnosis of after treatment system and troubleshooting

3.3.2.1 Fault classification

Type I fault: urea pressure build-up failure

Type II fault: Low urea consumption

Type III fault: OBD torque is limited and there are codes that cannot be cleared

Type IV fault: MIL

Type V fault: urea heating not released

Type VI fault: low NO_x conversion efficiency

Type VII fault: NO_x conversion efficiency monitoring not released

Type VIII fault: incorrect NO_x value measured

Type IX fault: ammonia smell

Type X fault: urea crystallization

Type XI fault: other faults

3.3.2.2 Troubleshooting

I) Urea pressure build-up failure

- Step 1: Read the flash code base on the flash code lamp, decide the fault point and focus on the pressure build-up related fault and faults of pressure build-up related parts (such as: spray nozzle, reversing valve, urea dosing pump, heater relay, resistance wires, exhaust gas temperature sensor, urea tank temperature sensor).
- Step 2: In cold regions, based on the fault code, first check the urea heating parts to ensure that the urea heating function is normal.
- Step 3: Related fault information can be obtain from Step 1; if there is no pressure build-up related function fault and only related part fault, please check the spray nozzle, reversing valve, urea dosing pump, heater relay, resistance wires, exhaust gas temperature sensor, urea tank temperature sensor and their harnesses, as the part fault may cause the system does not try to build up the pressure, the pressurized released upstream exhaust gas temperature is 180°C.
- Step 4: Power off and restart, if the system still does not try to build up the pressure, check whether the harnesses of the parts are reversely connected.
- Step 5: Related fault information can be obtain from Step 1; if there is pressure build-up related function fault but no related part fault, it indicates that the parts are normal; please check the installation of urea pipe and leakage and blockage, the system may tried to build up the pressure but failed.
- Step 6: Power off and restart, if the system tried to build up the pressure but failed, check whether the harnesses of the parts are reversely connected.
- Step 7: Poor signal quality may also lead to the system pressure build-up failure, such as signals for the level and temperature in the urea dosing pump.
- Step 8: check and calibrate the data if necessary.

II) Low urea consumption

- Step 1: Read the flash code based on the flash code lamp, decide the fault point and focus on the pressure build-up related fault and faults of pressure build-up related parts (such as: spray nozzle, reversing valve, urea dosing pump, heater relay, resistance wires, exhaust gas temperature sensor, urea tank temperature sensor).

- Step 2: In cold regions, based on the fault code, first check the urea heating parts to ensure that the urea heating function is normal.
- Step 3: Check whether the urea pressure build-up is normal; in case of pressure build-up failure, please refer to Type I fault for checking.
- Step 4: If the pressure build-up is successful, dismantle the spray nozzle for further check and observe whether the injection is normal. If the spray nozzle is mechanically stuck, it cannot be diagnosed.
- Step 5: Ask about the vehicle operating conditions; if the vehicle travels with low load for most time, it will lead to low exhaust gas temperature, the urea injection is not released (lowest temperature is 200°C).
- Step 6: Further check the harnesses to see whether the harnesses are reversely connected.
- Step 7: Check and calibrate the data if necessary.

III) OBD torque is limited and there are codes that cannot be cleared

- Step 1: Read the flash code based on the flash code lamp, decide the fault point; focus on the functional fault and part fault that lead to the OBD torque is limited and the existence of codes that cannot be cleared. See Appendix A for details.
- Step 2: Case on the result of fault code in Step 1, determine which fault causes the OBD torque limit and appearance of codes that cannot be cleared with reference to the table of “OBD torque limiting and codes that cannot be cleared”.
- Step 3: Check and calibrate the data if necessary;
- Step 4: Check and eliminate the faults referring to fault diagnostic manual.

IV) MIL

- Step 1: Read the flash code based on flash code lamp, decide the fault point; focus on the functional fault and part fault causing the MIL lights up.
- Step 2: Case on the result of fault code in Step 1, determine the fault causing the MIL lights up with reference to appendix A.
- Step 3: Check the MIL and its harness to verify whether the MIL functions normally.
- Step 4: Check and calibrate the data if necessary.
- Step 5: Check and eliminate the faults referring to fault diagnostic manual.

V) Urea heating not released

- Step 1: Read the flash code based on the flash code lamp, decide the fault point; focus on the faults related to urea heating and environment temperature sensor.
- Step 2: Base on the results in Step 1, check the environment temperature sensor and its harness if necessary to verify whether the sensor functions normally.
- Step 3: Base on the results in Step 1, check the urea heater relay, solenoid valve and the harnesses if necessary.
- Step 4: Base on the results in Step 1, check the urea heating resistance wire and harnesses and the urea tank heating water pipe.

Step 5: If the urea dosing pump heating fault is reported and the fault still exists after powering off and restarting, please replace the urea dosing pump if necessary.

Step 6: Check and calibrate the data if necessary.

Step 7: Check and eliminate the faults referring to fault diagnostic manual.

VI) Low NO_x conversion efficiency

Step 1: Read the flash code based on the flash code lamp, decide the fault point; focus on the fault related to NO_x conversion efficiency.

Step 2: Carry out the following checks in sequence:

- a) Check the NO_x sensor and exhaust pipe: if the measuring signal of NO_x sensor is stronger, it will cause the conversion efficiency fault;
- b) Check the urea injection: if the urea injection amount is less, it will cause the measuring signal of NO_x sensor stronger, which will lead to conversion efficiency fault;
- c) Check the spray nozzle: in case of spray nozzle faults (such as mechanically stuck or partially stuck, the system cannot detect the mechanical fault), the urea injection amount will be less, and this will cause the measuring signal of NO_x sensor stronger, which will lead to conversion efficiency fault;
- d) Check the urea pressure: if there is leakage from the urea pipe, the urea pressure will be lower, the actual urea injection amount will be less, causing the measuring signal of NO_x sensor stronger and conversion efficiency fault;
- e) Check the urea solution: if the urea solution quality is poor (low concentration low and high impurity content), it will lead to measuring signal of NO_x sensor stronger and the conversion efficiency fault;
- f) Check whether the urea is crystallized; if the crystallization formed inside the SCR box assembly, the conversion efficiency will slow down;
- g) Check the engine and SCR box assembly: if the aging of engine or SCR box assembly is serious, it will cause too much NO_x original emission or too strong measuring signal of NO_x sensor, which will lead to conversion efficiency fault;
- h) Check the factors related to environment: if the environment temperature/pressure sensor is failure and the vehicle travels in extreme (high altitude, cold, hot) environment, the fault of conversion efficiency will be reported, particularly in the high altitude regions;

Step 3: Check and calibrate the data if necessary; if the specific calibration for releasing the engine operating conditions is improper, the fault may be wrongly reported.

VII) NO_x conversion efficiency monitoring not released

Step 1: Read the flash code based on the flash code lamp, decide the fault point; focus on the fault related to NO_x conversion efficiency.

Step 2: Check the NO_x sensor, make sure that the NO_x sensor functions normally, the ECU can read the measured NO_x value and the NO_x sensor status is "1".

Step 3: Check the urea injection release conditions, including: SCR is in the dose control mode, the urea pressure is about 9bar, the exhaust gas temperature is above 200°C, make sure that the urea injection is

released.

- Step 4: Check the urea injection status and make sure that the urea is being injected.
- Step 5: Check the environment temperature and environment pressure sensors and their harnesses; make sure that the two sensors function normally, the environment pressure is above 900hpa and the environment temperature is above 2°C.
- Step 6: Make sure that the engine operating conditions are within the proper scope (exhaust gas temperature: >300°C, gas flow: >500kg/h).
- Step 7: Check and calibrate the data if necessary; if the specific calibration for release of engine working conditions is improper, the NO_x conversion efficiency monitoring will not be released.

VIII) Incorrect measured NO_x value

- Step 1: Read the flash code based on the flash code lamp, decide the fault point; focus on the faults related to NO_x signal.
- Step 2: Check the NO_x sensor and exhaust pipe; make sure that there is no much gas leakage from the exhaust pipe and the NO_x sensor is correctly installed. See the SCR after treatment system matching and installation specification for details.
- Step 3: Check the NO_x sensor harness; make sure that the communication and power supply are normal.
- Step 4: Check the exhaust back pressure; the exhaust back pressure affects the molecular number entering the NO_x sensor, thus affecting the NO_x measurement.
- Step 5: Check the proportions of NO and NO₂ in the exhaust gas; if the NO₂ proportion is higher, the measured NO_x value is higher.
- Step 6: Check and calibrate the data if necessary; confirm that the release of sending and receiving of NO_x sensor related message are correct.

IX) Ammonia smell

- Step 1: Read the flash code based on the flash code lamp, decide the fault point; focus on the urea injection amount related faults, including parts: speed sensor, fuel injector, air intake pressure/temperature sensors, exhaust gas temperature sensor, spray nozzle, and urea pressure sensor.
- Step 2: Check the speed sensor and its harness; the speed signal is one basis for calculating the urea injection amount.
- Step 3: Check the fuel injection; if the actual fuel injection amount is less than the set amount, the urea injection amount will be relatively too much.
- Step 4: Check the air intake pressure/temperature sensors and their harnesses; the air intake is one basis for calculating the urea injection amount.
- Step 5: Check the exhaust gas temperature sensor and its harness; the exhaust gas signal is one basis for calculating the urea injection amount.
- Step 6: Check the urea pressure sensor and its harness; if the measuring difference of urea pressure signal is excessive, it will cause the correction of urea injection amount based on urea pressure is larger, which will lead to too much urea injection.

Step 7: Check the spray nozzle and its harness; if the nozzle is stuck at the normally open position, the urea injection amount will exceed the set amount too much.

Step 8: Check and calibrate the data if necessary; make sure that the calibration of engine original emission and air intake are precise.

X) Urea crystallization

Step 1: Read the flash code based on the flash code lamp, decide the fault point; focus on the faults related to NO_x conversion efficiency and NO_x signal.

Step 2: Too much urea injection amount is one cause of urea crystallization, please refer to the check method and steps of Type IX fault.

Step 3: Check the design and material of exhaust pipe.

Step 4: Check the design and material of spray nozzle base.

Step 5: Check whether the injection direction of nozzle meets the specification.

Step 6: Check and calibrate the data if necessary; make sure that the calibration of engine original emission and air intake are precise.

Part IV Diesel Engine Disassembly and Assembly

4.1 Overview

During the engine disassembly and assembly, please adhere to the instructions in this manual strictly and note the danger signs and safety signs indicated in this manual to ensure personal safety and avoid accidents.

The disassembly procedure is in reverse order to that of assembly, so, if no special remark is required, only one kind of steps will be given in this manual.

The tightening torque of special bolts will be given in the related installation steps; please refer to the Part V Tightening Torque of Standard Bolts if no special remark is given.

4.1.1 Danger signs

This is a world-recognized warning sign. In this manual, the sign is used to emphasize the importance of the following information. Make sure that you understand the consequence of hazardous conditions and how to avoid such dangers. The violation of such warning information can lead to property loss, personal injury and even personal casualty.

The common danger signs are usually used to indicate general warning. In this manual, the warning information are classified as per the levels of hazard effect (minor injury-related, severe injury-related, and death related).



This warning sign indicates a potential hazard which can lead to serious injury even death or great property loss, if the occurrence cannot be avoided



This warning sign indicates a potential hazard which can lead to slight injury or property loss, if the occurrence cannot be avoided. It can also be used to hazardous operation warning.

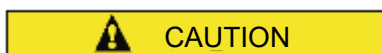

The cautions in this manual can indicate how to properly operate and safely use the engine manufactured by the company. However, the potential hazards cannot be removed by reading the manual. The considerations will not be beneficial to the correct use unless the implication is properly understood.

The warning information in the manual cannot cover all possible conditions! To apply an application or method beyond those recommended in this manual, make sure that the operation will never cause any danger to you, to others or to the equipment.

4.1.2 Safety signs







Table 4-1 Safety signs

Figure	Definition
	Wear hand protector
	Wear ear protector
	Wear eye protector
	Wear head protector
	Wear foot protector
	Wear protective mask
	Wear protective clothing
	No open flame
	No smoking
	No mobile phone
	Danger: battery acid
	Danger: live cable, electric shock hazard
	Combustibles
	Stay away from suspended heavy object
	Fire extinguisher nearby

Many potential dangers can be present unexpectedly when the engine is in running. Therefore, this manual cannot warn each potential danger specifically. To apply a procedure beyond special recommendation, make sure that the procedure runs safely without any property loss.

4.1.3 Tools used

Table 4-2 Tools

Figure	Definition
	2.5mm hexagon wrench
	5mm hexagon wrench
	8mm socket
	Slotted screwdriver
	Special tool
	10mm flat-ended hexagon wrench

To use a method or tool beyond those recommended in this manual, the user shall always ensure the personal safety, avoid danger of life to the user or to others, meanwhile, make sure that the use, maintenance or repair method will not result in damage risk or safety hazard.

4.1.4 Health protection considerations

The following “health care considerations” are specified to reduce the risk of engine maintenance staffs suffering from any contamination.

- a) Avoid repeated exposure to used oil for a long time;
- b) Wear the protective clothing and water-proof gloves properly, if available;
- c) Do not place the oily rag in the pocket;
- d) Avoid contaminating clothes especially underwear with oil;
- e) Wash working clothes regularly, and throw away the oil-impregnated clothes and shoes that cannot be cleaned up;
- f) In case of cut and injury, take first-aid measures as soon as possible;
- g) Before working, always apply some protective cream which will make it easier to remove the oil in case that the skin is contaminated with mineral oil;
- h) Use soap and hot water, or liquid soap and nail brush to wash hands for the convenience of removing all oil stains. If the grease secreted by skin is washed off, the product containing lanum can moisturize the skin;
- i) Do not clean the skin with any gasoline, kerosene, fuel, thinner or solvent;

- j) If the skin is discomfort, seek for medical care immediately;
- k) Remove oil from the parts before transportation, if available;
- l) If the eyes are under threaten, wear goggles or protective mask. Always prepare eyes wash liquid within reach;
- m) To repair the engine, do not splash oil or other liquid on the floor. If hydrocarbon or other liquid leaks unexpectedly, take all essential measures to isolate the area to keep the environment clean and to protect the personnel from injury;
- n) The hydrocarbon, ethylene, glycol or petroleum shall be transferred, stored and recycled under the safety and environment standard in the local country.

4.1.5 Environmental protection measures

For used oil and hydrocarbon handling, refer to the relevant environmental protection regulations. Consult the local officials for details.

4.1.6 Considerations for engine disassembly and assembly

Most of engine use, maintenance and repair concerned accidents are caused because the safety rules and basic precautions are not observed. Therefore, you shall be aware of the danger lying ahead and take the corresponding measures to avoid the accident. Only the well-trained personnel with required skills and appropriate tools can operate, maintain and repair the engine.

The violation of instructions in the manual can lead to serious accident, and even endanger life. Weichai Power Co., Ltd. cannot foresee all potential dangers, meanwhile, the rules and instructions specified in this manual are not meant to be comprehensive.

Before continuing the maintenance or repair, place “DO NOT USE” sign board or similar signs on the starter switch.

Take necessary precautions for using barring bar;

Make sure that the repair area and the surroundings are applicable for safe operation;

Make sure that the surrounding of service shop or engine is clean and tidy;

Before working, remember to remove the ring, necklace and watch, and wear well fitted working clothes;

Before working, verify whether the corresponding protective equipment (goggles, gloves, shoes, mask, working cloth, helmet etc.) are within the validity;

Do not use the failure or inappropriate tools.

During the maintenance or repair, shut down the engine.

4.2 Engine Block Group

4.2.1 Disassembly and assembly of engine block group

4.2.1.1 Exploded view of engine block group

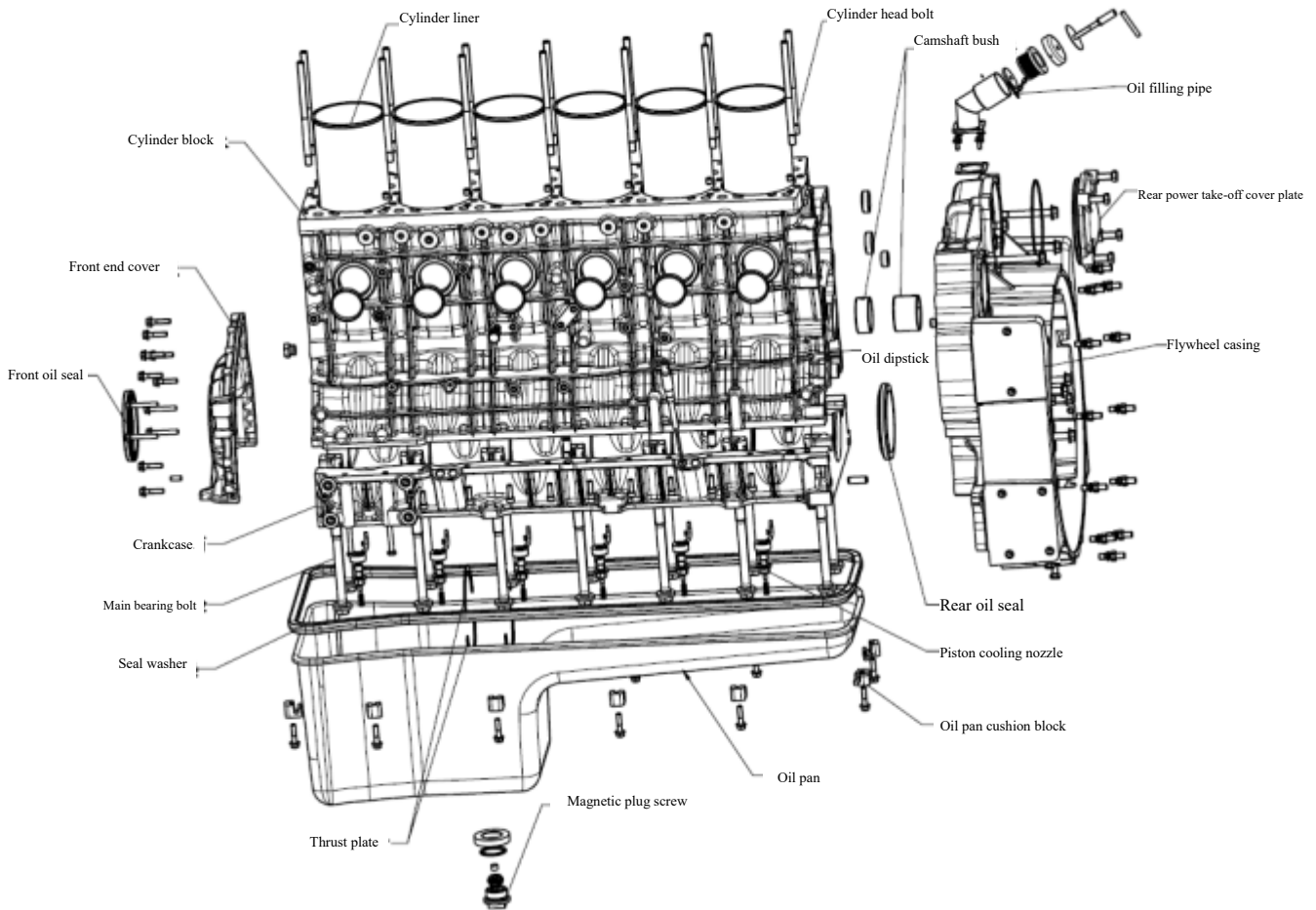

Figure 4-1 Exploded view of engine block group

4.2.1.2 Disassembly of engine block group

The disassembly procedure is as follows:

- 1) Disassemble the oil pan. Refer to “disassembly of oil pan assembly” for details;
- 2) Disassemble the oil dipstick. Refer to the “disassembly of oil dipstick assembly” for details;
- 3) Disassemble the oil filling pipe. Refer to “disassembly of oil filling pipe assembly” for details;
- 4) Disassemble the flywheel housing. Refer to “disassembly of flywheel housing assembly” for details;
- 5) Disassemble the rear oil seal;
- 6) Disassemble the front end cover. Refer to “disassembly of front end cover assembly for details;
- 7) Disassemble the front oil seal;
- 8) Unscrew the secondary bolts of cylinder head and camshaft bush. Unscrew the main bearing bolts and crankcase fastening bolts. Disassemble the crankcase. Remove the oil gallery plug screw, etc. Refer to “disassembly of cylinder block preassembly” for details;
- 9) Disassemble the thrust plate. Refer to “disassembly of thrust plate” for details;
- 10) Disassemble the piston cooling nozzle. Refer to “disassembly of piston cooling nozzle” for details.

4.2.1.3 Assembly of engine block group

The assembly procedure is in reverse order to that of disassembly.

4.2.2 Disassembly and assembly of cylinder block preassembly

4.2.2.1 Exploded view of cylinder block preassembly

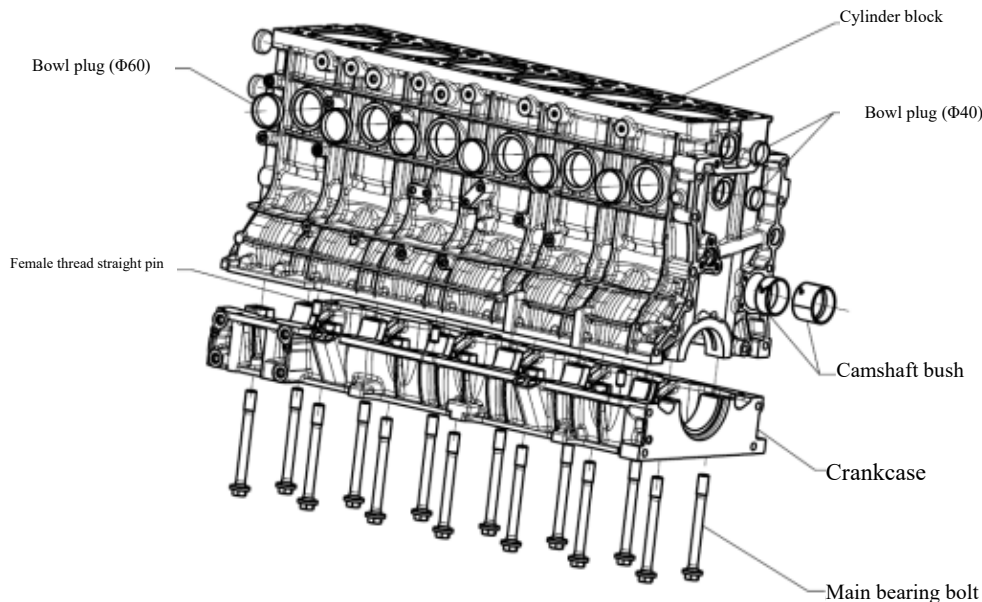

Figure 4-2 Exploded view cylinder block preassembly

4.2.2.2 Disassembly of cylinder block preassembly

- 1) Remove the female thread straight pin;
- 2) Disassemble the camshaft bush;
- 3) Unscrew the main bearing bolts;
- 4) Disassemble the crankcase.

4.2.2.3 Inspection and maintenance of cylinder block preassembly

- 1) Disassemble the camshaft bush with special tools. Take care to protect other bushes during disassembling.
- 2) Before assembling, check carefully the inner surface of camshaft bush for scratches. Replace the camshaft bush if necessary. Align the oil hole in camshaft bush with the oil hole of camshaft bore of engine block.
- 3) Before assembling, take care to clean the top surface of crankcase and lower plane of cylinder block. The top surface of crankcase should be applied with sealant.
- 4) Assemble the main bearing bolts. Tighten them symmetrically in sequence indicated in the following figure. Before assembling, apply clean lubricating oil to bearing surface of crankcase and threads of main bearing bolts.

Torque control: first time, tighten with a small-torque pneumatic wrench; second time, tighten up to 80 Nm; third time, tighten up to 140 Nm; fourth time: turn by 70° in sequence; fifth time, turn by 70° in sequence again; sixth time, turn by 70° in sequence again.

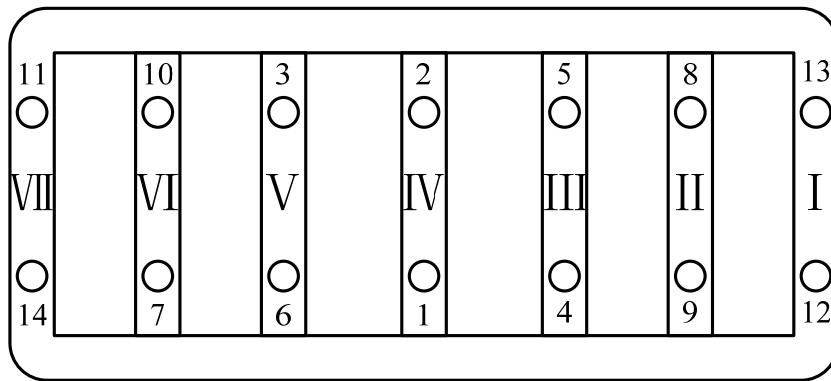

Figure 4-3 Tightening sequence of main bearing bolts

4.2.2.4 Assembly of cylinder block preassembly

The assembly procedure is in reverse order to that of disassembly.

4.2.3 Disassembly and assembly of piston cooling nozzle

4.2.3.1 Exploded view of piston cooling nozzle

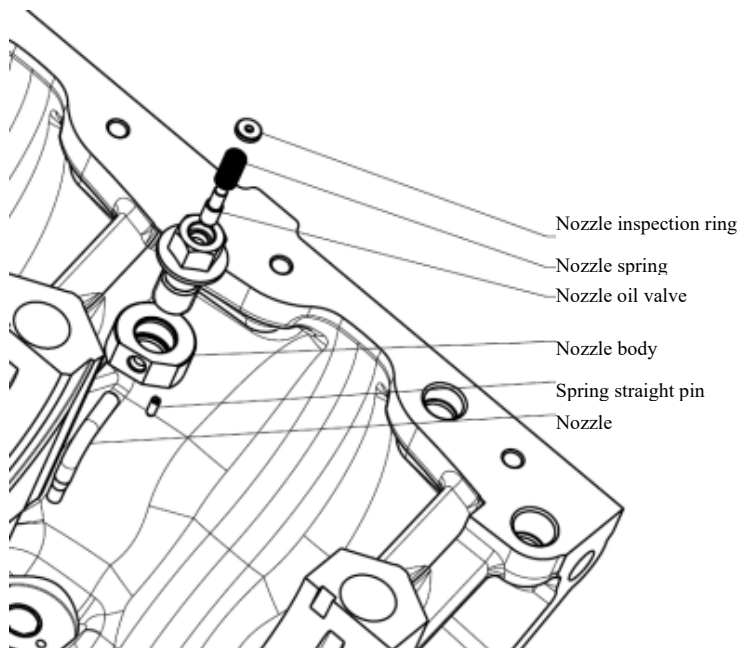

Figure 4-4 Exploded view of piston cooling nozzle

4.2.3.2 Disassembly of piston cooling nozzle

- 1) Unscrew the hollow bolt;
- 2) Disassemble the nozzle assembly;
- 3) Disassemble the spring straight pin.

4.2.3.3 Inspection and maintenance of piston cooling nozzle

- 1) The tightening torque of hollow bolt is 20-30Nm;

2) Before assembling, check if the locating pin is missing or damaged and replace it if necessary. Align the locating pin with the pinhole in the engine block, and knock gently the nozzle body with a copper hammer to completely fit the locating pin into the pinhole in engine block.

4.2.3.4 Assembly of piston cooling nozzle

The assembly procedure of piston cooling nozzle is in reverse order to that of disassembly.

4.2.4 Disassembly and assembly of thrust plates

4.2.4.1 Exploded view of thrust plates

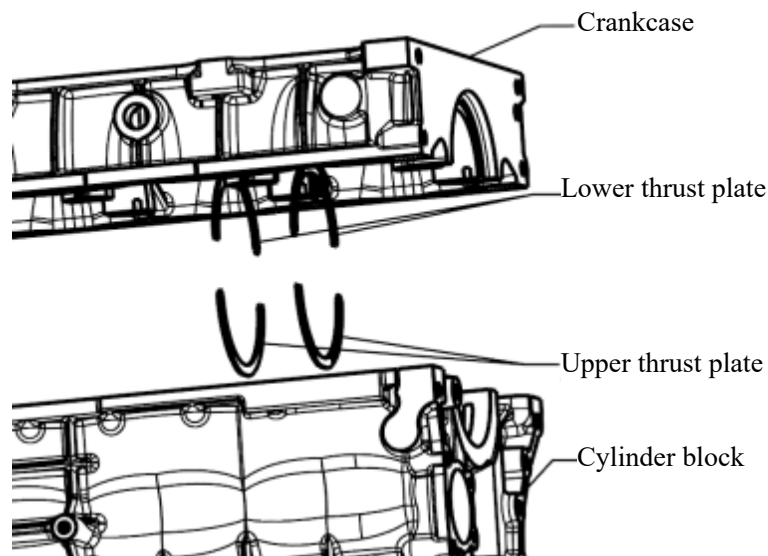

Figure 4-5 Exploded view of thrust plates

4.2.4.2 Disassembly of thrust plates

- 1) Disassemble the crankcase;
- 2) Disassemble the crankshaft;
- 3) Disassemble the thrust plates.

4.2.4.3 Inspection and maintenance of thrust plates

1) The thrust plates should be used in pairs. When assembling, first install the crankshaft into the engine block, and install the upper thrust plate (earless); apply grease to the lower thrust plate and attach it to the crankcase and assemble it together with the crankcase. The oil groove side of thrust plate is directed to the crank arm side.

4.2.4.4 Assembly of thrust plates

- 1) Assemble the crankshaft;
- 2) Assemble the upper thrust plate;
- 3) Assemble the lower thrust plate.

4.2.5 Disassembly and assembly of front and rear oil seals

4.2.5.1 Exploded view of front and rear oil seal assembly

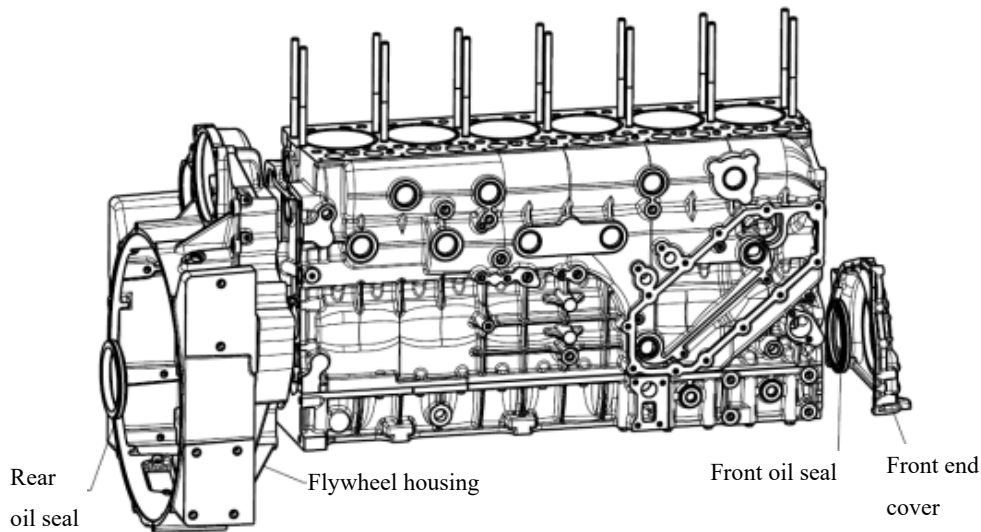

Figure 4-6 Exploded view of oil seal assembly

4.2.5.2 Disassembly of front and rear oil seals

- 1) Disassemble the front end cover;
- 2) Disassemble the front oil seal;
- 3) Disassemble the flywheel housing;
- 4) Disassemble the rear oil seal.

4.2.5.3 Inspection and maintenance of front and rear oil seals

- 1) Once disassembled, the oil seals cannot be reused any more.
- 2) Before installing the oil seal, clean the mounting hole and oil seal; no dirt is allowed. Special tools should be used to install the oil seal; the oil seal should be pressed in steadily. Before installation, the oil seal and press-fit tools should be lubricated with oil.

4.2.5.4 Assembly of front and rear oil seals

- 1) Assemble the front end cover;
- 2) Assemble the front oil seal;
- 3) Assemble the flywheel housing;
- 4) Assemble the rear oil seal.

4.2.6 Disassembly and assembly of front end cover

4.2.6.1 Exploded view of front end cover

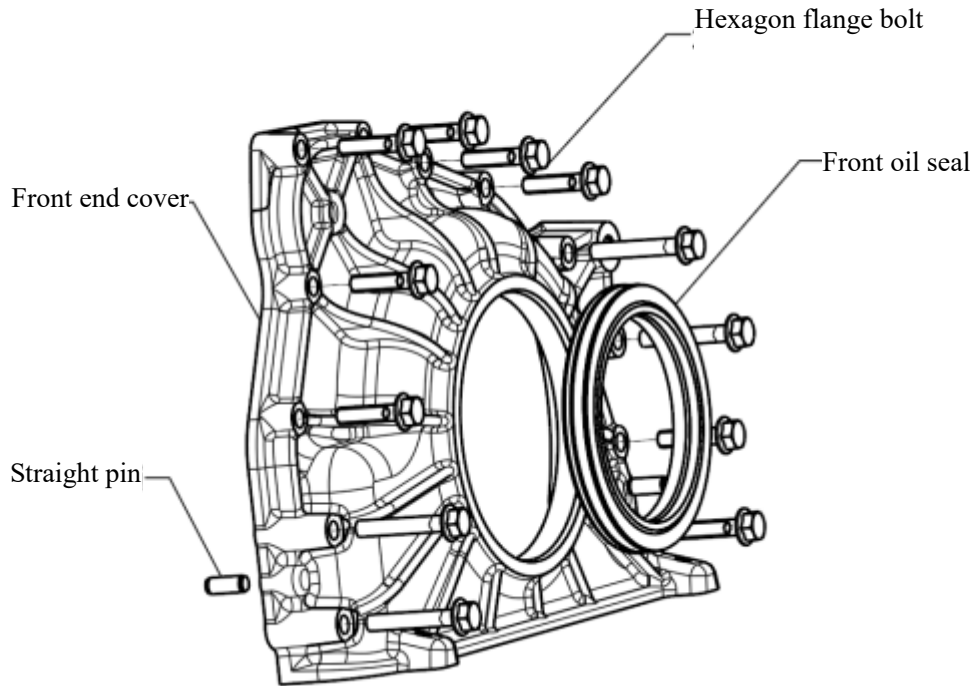

Figure 4-7 Exploded view of front end cover

4.2.6.2 Disassembly of front end cover

- 1) Unscrew the fastening bolts to front end cover and disassemble the front end cover;
- 2) Remove the locating straight pin of front end cover;
- 3) Disassemble the front oil seal.

4.2.6.3 Inspection and maintenance of front end cover

- 1) The fastening bolts to front end cover should be precoating sealant type;
- 2) Evenly apply sealant onto the interface between the cylinder block and front end cover; take care to prevent impact damages to binding face between the front end cover and engine block and the oil pan.

4.2.6.4 Assembly of front end cover

- 1) Mount the locating straight pin;
- 2) Mount the front end cover, and tighten the fastening bolts;
- 3) Press fit the front oil seal.

4.2.7 Disassembly and assembly of flywheel casing

4.2.7.1 Exploded view of flywheel casing

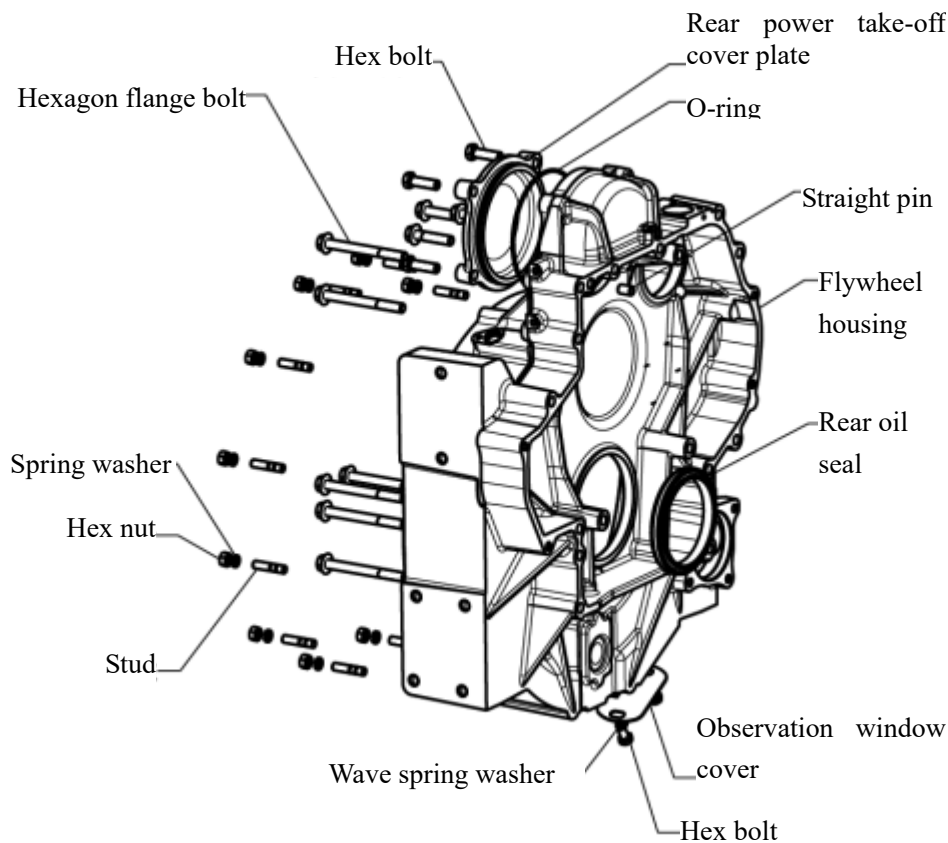

Figure 4-8 Exploded view of flywheel housing

4.2.7.2 Disassembly of flywheel housing

- 1) Unscrew the fastening bolts of rear power take-off cover plate and disassemble the rear power take-off cover plate;
- 2) Unscrew the fastening bolts of observation window cover and disassemble the observation hole cover;
- 3) Unscrew the studs at outer edge of flywheel housing;
- 4) Unscrew the fastening bolts of flywheel housing diagonally;
- 5) Disassemble the flywheel housing, straight pin and rear oil seal.

4.2.7.3 Inspection and maintenance of flywheel housing

- 1) Coat adhesive to the bolts of flywheel housing and tighten them symmetrically; before installing, apply oil on the bolt flange face; the bolts of flywheel housing can be reused for two times;
- 2) When installing, the binding face between the cylinder block and flywheel housing shall be applied with sealant evenly and continuously. Take care to prevent impact damages to flywheel housing when hoisting it.
- 3) After lubricating the threads and bearing surfaces of flywheel bolts, screw the bolts into the threaded holes and tighten them diagonally. The tightening torque is 110-140Nm.

4.2.7.4 Assembly of flywheel housing

- 1) Install the straight pin, and install the flywheel housing in place;
- 2) Screw on the bolts and tighten the fastening bolts to flywheel housing diagonally;

- 3) Screw on the studs at outer edge of flywheel housing;
- 4) Install the rear power take-off cover plate;
- 5) Press fit the rear oil seal;
- 6) Install the observation hole cover.

4.2.8 Disassembly and assembly of oil pan

4.2.8.1 Exploded view of oil pan

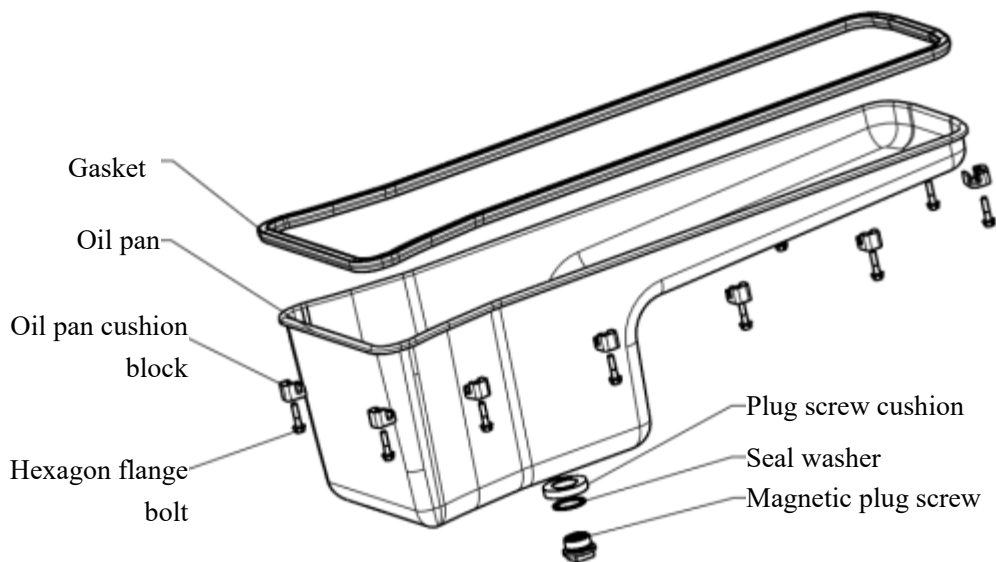

Figure 4-9 Exploded view of oil pan

4.2.8.2 Disassembly of oil pan

- 1) With the oil pan of diesel engine facing upward;
- 2) Unscrew the tightening bolts of oil pan;
- 3) Disassemble the oil pan cushion blocks;
- 4) Disassemble the oil pan and gasket;
- 5) Disassemble the magnetic plug screw, seal washer and plug screw cushion.

4.2.8.3 Inspection and maintenance of oil pan

- 1) Drain off the oil before disassembling the oil pan. Place the oil container under the oil drain plug, and unscrew the plug with a plug wrench to drain the oil.
- 2) The fastening bolts of oil pan shall be tightened in sequence indicated in the following figure with torque of 22-29Nm;

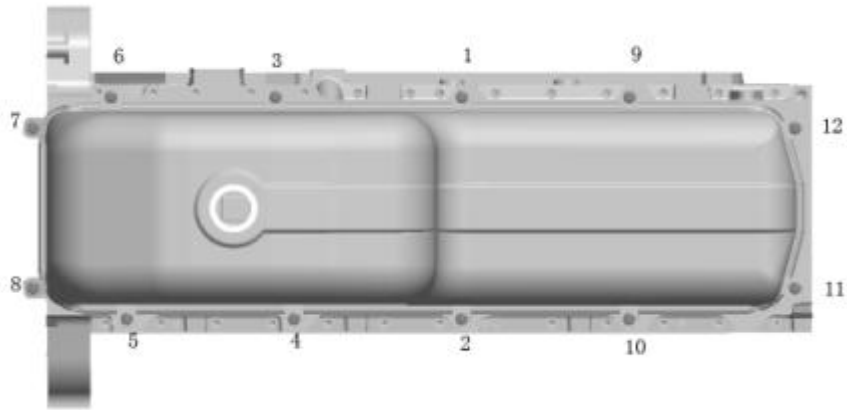

Figure 4-10 Tightening sequence of oil pan fastening bolts

4.2.8.4 Assembly of oil pan

The assembly procedure of oil pan is in reverse order to that of disassembly.

4.2.9 Disassembly and assembly of cylinder head

4.2.9.1 Exploded view of cylinder head

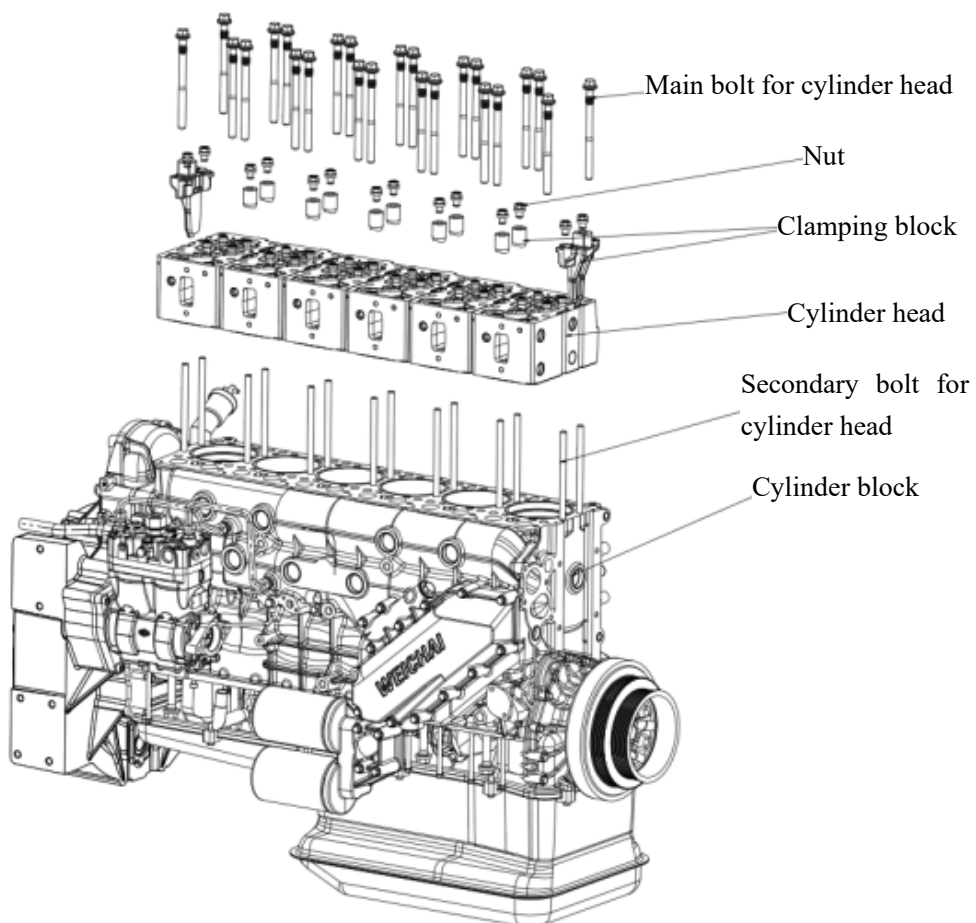

Figure 4-11 Exploded view of cylinder head

4.2.9.2 Disassembly of cylinder head

Before disassembling the cylinder head, first disassemble the parts installed on it. We need to disassemble the intake manifold and exhaust manifold, fuel piping and harnesses, cylinder head cover, oil-gas separator and gas bleeder. Disassembling procedure is as follows:

- 1) Unscrew the nuts of secondary bolts for cylinder head, and take off the clamping blocks. For the clamping block, there are two structures: one is installed between two cylinder heads, and the other is installed on the cylinder head at front and rear side of engine;
- 2) Unscrew the main bolts for cylinder head;
- 3) Disassemble the fuel injector. As the spray nozzle of fuel injector is projecting out of the bottom plane of cylinder head, before disassembly the cylinder head, make sure that all the fuel injectors have been disassembled, or otherwise the fuel injector nozzle will be easily damaged when placing the cylinder head;
- 4) Disassemble the cylinder head. Place the disassembled cylinder head on a paperboard to avoid wear on top surface of combustion chamber and other sealing surfaces. If it is necessary to disassemble more than one cylinder head, we need to mark the cylinder number on the cylinder heads to ease subsequent analysis of and solutions to any problems;
- 5) Disassemble the cylinder head gasket. If it is necessary to disassemble more than one cylinder head gasket, we need to mark the cylinder number on the cylinder head gaskets to ease subsequent analysis of any problems;
- 6) If it is necessary to replace or to inspect the secondary bolts for cylinder head, we need to disassemble the secondary bolts of cylinder head;
- 7) Disassemble the rocker arm bracket, intake and exhaust valves and other valve mechanisms;
- 8) If it is necessary to inspect or replace the valve rod seal, then disassemble it with either a special tooling or with a pair of pliers clamping the outer sidewalls of the valve rod seal, and lift and rotate it to take off the valve rod seal; once disassembled, the valve rod seal cannot be reused any more.

4.2.9.3 Inspection and maintenance of cylinder head

- 1) Before disassembling the cylinder head, first check the junction between cylinder head and the engine block for water, oil and gas leakages as well as other abnormalities. If any of such problems exists, replace the cylinder head gasket to see if the problem remains; refer to this section for disassembly and assembly methods of cylinder head gaskets.
- 2) Check carefully the appearance of cylinder head for color change and cracks; perform dye check if cracks are detected.
- 3) Before disassembly the valve train, check the valve sinkage. The valve sinkage is the vertical distance from the valve bottom face to the bottom plane of cylinder head, and the difference between the measured value and required value may indirectly reflect the degree of wear between the valve and the valve seat. The valve sinkage can be measured with a depth micrometer, as shown in Figure 4-12.

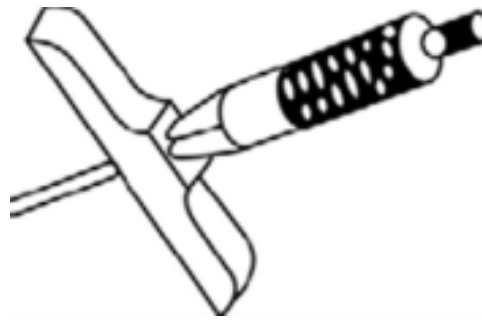

Figure 4-12 Depth micrometer

Refer to Table 4-3 for the required values of valve sinkage. If the valve sinkage exceeds the permissible range, it is necessary to confirm the wear on valve and valve seat. The wear on valve seat can be checked by measuring the valve sinkage after the new valve is installed. If the valve sinkage still exceeds the required value, then it is necessary to replace the cylinder head so as to ensure the reliability of diesel engine. If the valve sinkage does not exceed the permissible value, disassemble the valve and check if the sealing surface between the valve and the valve retainer has obvious wear or abnormal damage.

Table 4-3 Required value of valve sinkage

	Required value of valve sinkage (mm)
Intake valve	± 0.2
Exhaust valve	± 0.2

- 4) After the valve train is disassembled, check the inside of intake and exhaust passages of cylinder head for water leakage; in case of any water leakage, it is necessary to clean the cylinder head and perform dye check to identify the location of problems, and replace the cylinder head if necessary.
- 5) Clean the cylinder head, particularly the surface of combustion chamber, valve seat, intake and exhaust valves and intake and exhaust passages; remove the carbon deposit, viscose, etc. from the surfaces and check the conditions of surfaces.
- 6) Check the bore of valve guide. The bore of valve guide is the contact area between the valve guide and the valve; if the wear exceeds the permissible value, the guiding effect will be affected and therefore, the operational reliability of diesel engine is reduced. The size of bore of valve guide can be measured with an inside micrometer, as shown in Figure 4-13. The permissible range of valve guide bore diameter is 9-9.015 mm; if it is exceeded, it is necessary to replace the cylinder head to ensure the operational reliability of diesel engine.

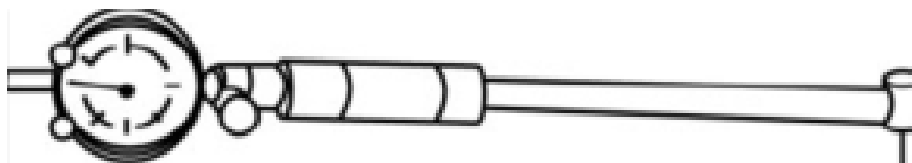

Figure 4-13 Inside micrometer

- 7) Disassemble the cylinder head gasket. Check if the cylinder head gasket is damaged and analyze the causes; no matter whether it is damaged, a new gasket shall be used once disassembled.

8) Before disassembly, check if the rubber lip of valve rod seal is damaged, if the spring is ineffective and if there is other abnormalities. However, it is necessary to replace the valve rod seal whenever it is disassembled.

4.2.9.4 Assembly of cylinder head

1) Installation of secondary bolt for cylinder head.

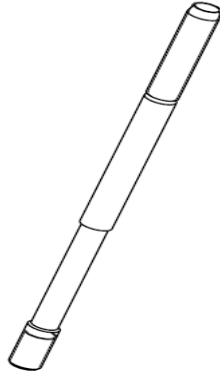

Figure 4-14 Secondary bolt for cylinder head

- ① The secondary bolt for cylinder head can be used for three times; Please replace the bolts after they have been used for three times;
 - ② Apply anaerobic thread locker 262 on the screwing in portion of cylinder head bolt (the end with shorter thread);
 - ③ Clean the threaded hole in the cylinder block;
 - ④ Tighten the bolt with torque of (20+10) Nm.
- 2) Installation of the cylinder head gasket

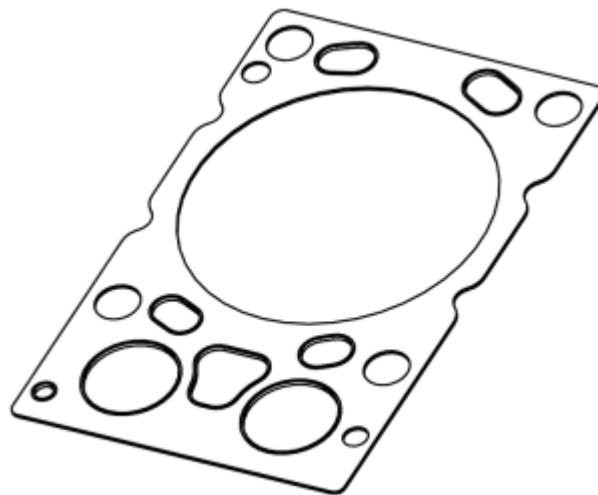

Figure 4-15 Cylinder head gasket

- ① The cylinder head gasket can only be used once, and it must be replaced once the cylinder head is overhauled;
- ② Clean the inner wall of cylinder liner, and apply clean lubricating oil; Clean the top surface of engine block, and then install the cylinder head gasket with the pin holes aligned;

④ Check if the holes in the cylinder head gasket are aligned with those in the cylinder block; Check if the cylinder head gasket has been correctly installed.

3) Installation of valve rod seal

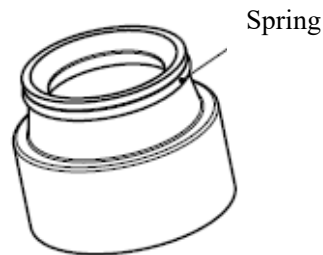

Figure 4-16 Valve rod seal

- ① The valve rod seal can only be used once, and it must be replaced once it is overhauled;
- ② Check if the valve rod seal is defective, and if spring of valve rod seal is intact;
- ③ Install the valve rod seal on the valve guide;
- ④ Apply lubricating oil onto the lip of valve rod seal;
- ⑤ Press fit the valve rod seal with special tool and rubber hammer.

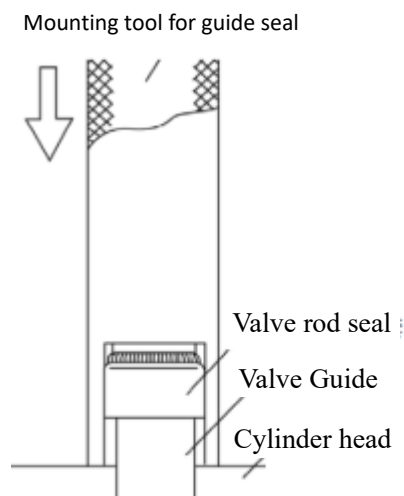

Figure 4-17 Installation of valve rod seal

4) Installation of cylinder head

- ① Carefully clean the cylinder head and ensure that it is free of dirt like dust and sand, and then clean the lower plane of cylinder head;
- ② Make sure that there is no foreign material inside the air passage, water passage and cylinder liner, and the cylinder head gasket and lower plane of cylinder head are clean;
- ③ Before tightening the bolts of cylinder head, the cylinder head shall be located with pin and plane location method;
- ④ Install the cylinder head.

5) Installation of clamping block

- ① Clean the clamping blocks;
- ② After the clamping block bearing surface is applied with clean lubricating oil, install them in sequence onto the cylinder head; The amount of lubricating oil applied should be appropriate, and take care to prevent the lubricating oil from entering into the seams among the cylinder heads;
- ③ The clamping blocks shall be installed with their grooves in the same direction with the seams among cylinder heads;
- ④ Screw by hand the nut onto the secondary bolt to the cylinder head.

6) Installation of cylinder head bolt

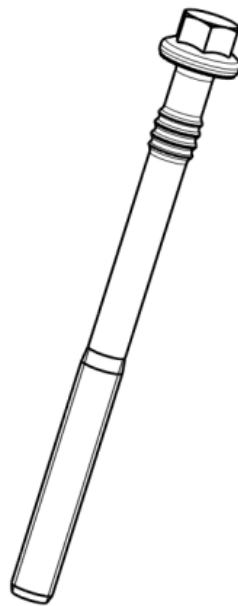

Figure 4-18 Main bolt for cylinder head

- 1) Main bolt for cylinder head can only be used for three times;
- 2) Center in sequence the cylinder heads, and apply an appropriate amount of clean lubricating oil onto the threads, bearing surfaces at the shoulder of main bolts for cylinder head and flange nuts, and then install them onto the cylinder head, secondary bolt for cylinder head and clamping block respectively;
- 3) Tighten with torque wrench the main bolts to cylinder head to (60 ± 6) Nm and the nuts of secondary bolts to cylinder head to (25 ± 3) Nm;
- 4) Knock the clamping blocks to let them fall in place;
- 5) Rotate in sequence the nuts of secondary bolts with a torque wrench by $120^\circ\pm 5^\circ$ and mark the nuts;
- 6) Rotate in sequence the main bolts with a torque wrench by $120^\circ\pm 5^\circ$ and mark the bolts;
- 7) Rotate in sequence the nuts of secondary bolts with a torque wrench by $120^\circ\pm 5^\circ$ and mark the bolts;
- 8) Rotate in sequence the main bolts with a torque wrench by $120^\circ\pm 5^\circ$ and mark the bolts.

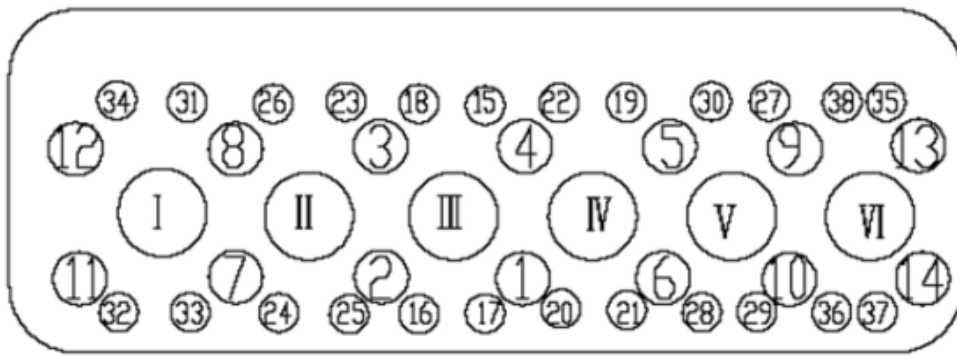

Figure 4-19 Main bolts for cylinder head

The numbers of bolts in Figure 3-19 include:

The secondary bolts of M12×1.5 are numbered from 1 to 14 (studs);

The main bolts are numbered from 15 to 38.

4.2.10 Disassembly and assembly of cylinder head cover

4.2.10.1 Exploded view of cylinder head cover

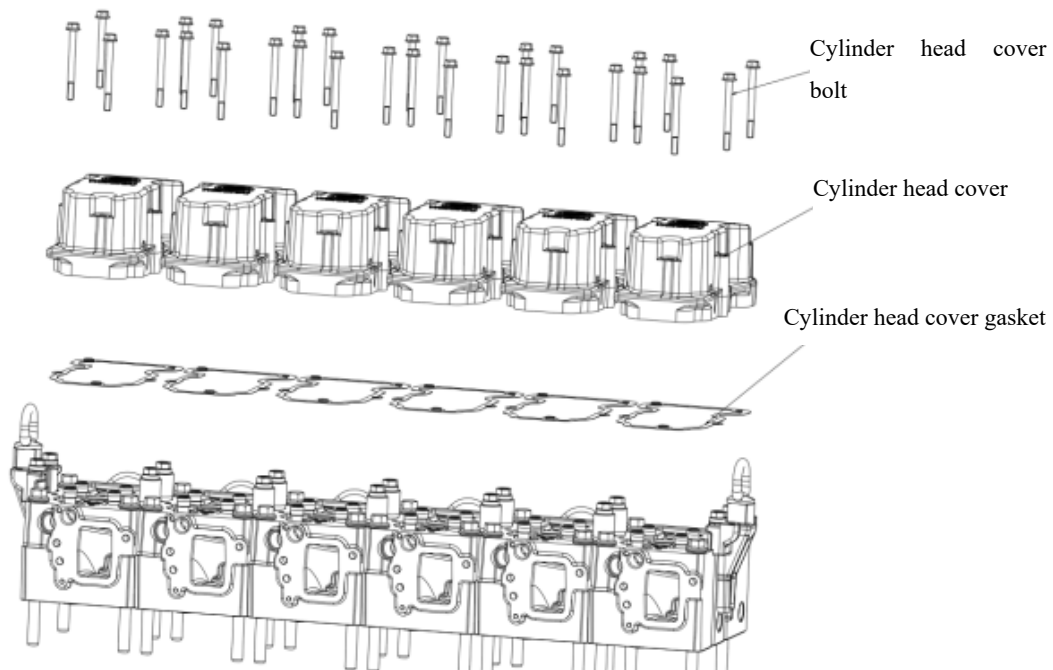

Figure 4-20 Exploded view of cylinder head cover

4.2.10.2 Disassembly of cylinder head cover

Loosen in sequence the bolts of cylinder head cover, and take out the cylinder head cover and gasket vertically, as shown in Figure 4-20.

4.2.10.3 Inspection and maintenance of cylinder head cover

1) Check the cylinder head cover for cracks, wear and other damages, and replace the cylinder head cover if necessary.

2) If there is sign of oil leak at cylinder head gasket, it is necessary to check if the cylinder head gasket is ineffective and check the degree of surface wear on upper plane of cylinder head and the sealing surface of cylinder head cover; if there is sign of oil leak, it is necessary to replace the cylinder head cover gasket and check if there is still oil leak.

4.2.10.4 Assembly of cylinder head cover

- 1) The cylinder head gasket can only be used once; and it must be replaced whenever the cylinder head is overhauled. Before installing the cylinder head gasket, first check the new cylinder head gasket for manufacture and use defects and damages.
- 2) Clean the upper surface of cylinder head, and correctly install the cylinder head gasket.
- 3) Clean the cylinder head cover, and correctly install it onto the cylinder head.
- 4) Fit and tighten the bolts for cylinder head cover.

4.2.11 Disassembly and assembly of engine lifting eye

4.2.11.1 Exploded view of engine lifting eye

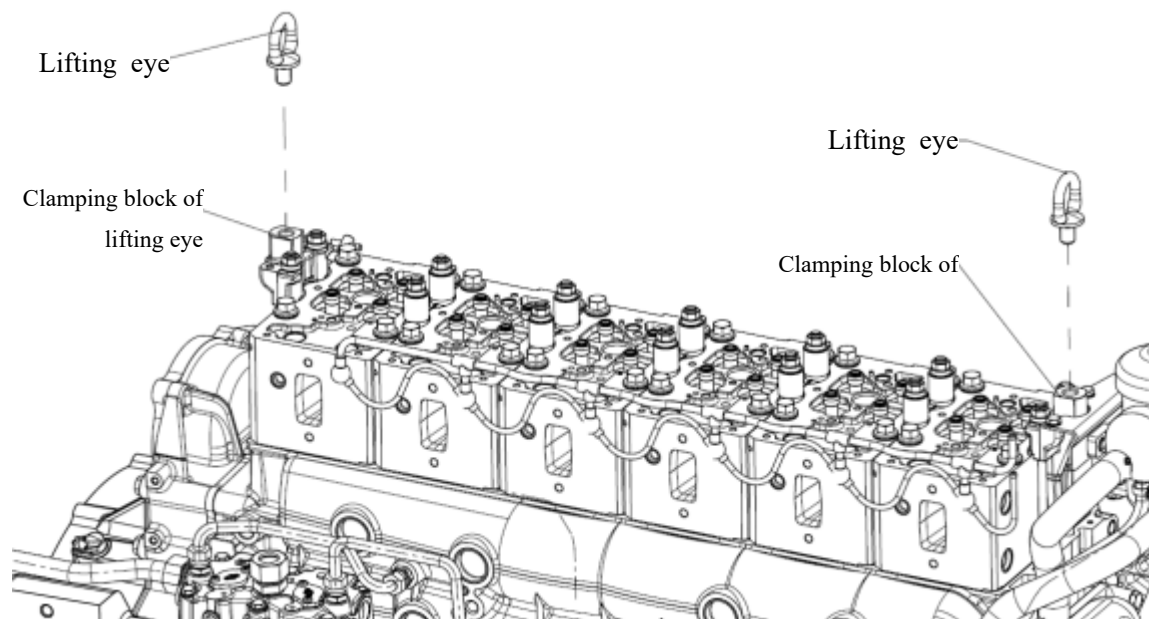

Figure 4-21 Exploded view of lifting eye

4.2.11.2 Disassembly of engine lifting eye

The lifting eyes are bolted to the clamping blocks for lifting the engine. To disassemble it, loosen the thread to take out the lifting eye.

4.2.11.3 Inspection and maintenance of engine lifting eye

Perform disassembling inspection on the lifting eye for cracks, deformation and other failure modes. If there are above-said failure modes, to prevent safety accidents, the lifting eye should be replaced.

4.2.11.4 Assembly of engine lifting eye

The assembly procedure of engine lifting eye is in reverse order to that of disassembly.

4.2.12 Disassembly and assembly of oil-gas separator

4.2.12.1 Exploded view of oil-gas separator

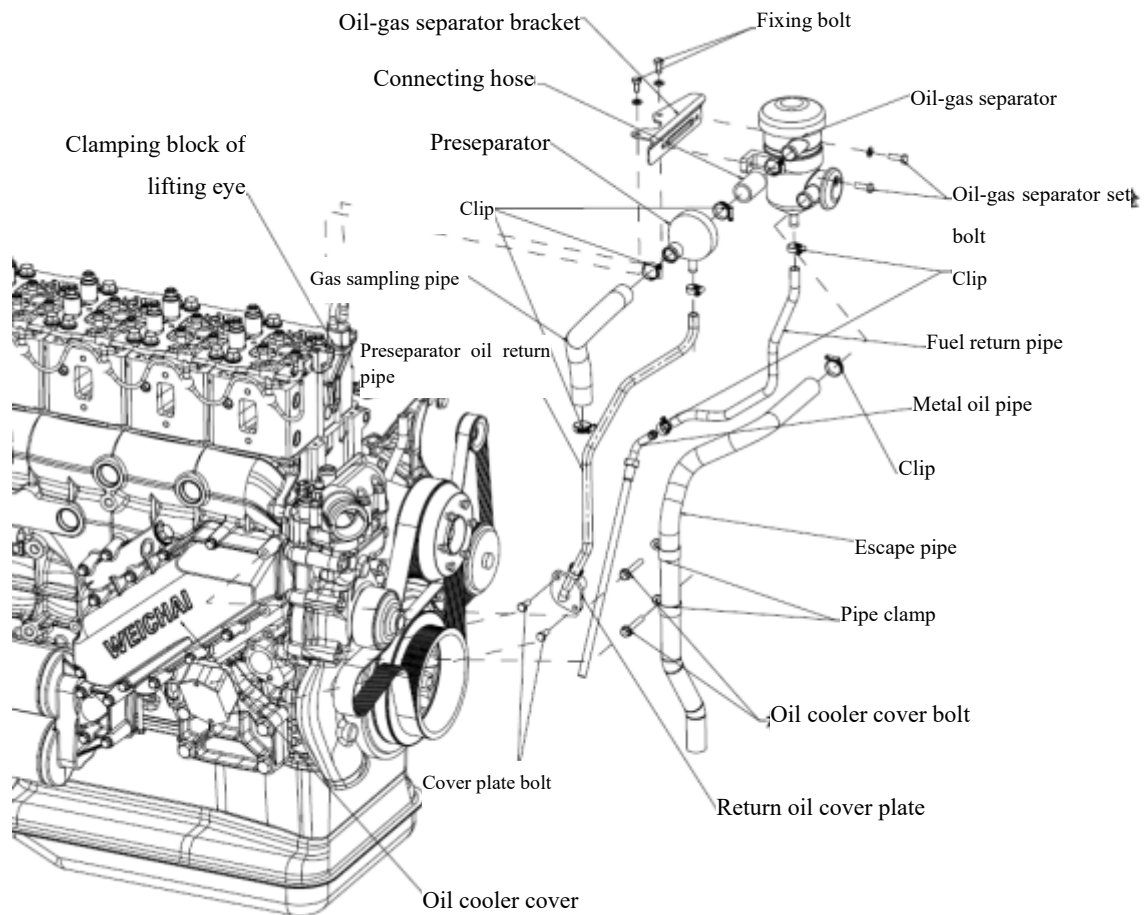

Figure 4-22 Exploded view of oil-gas separator

4.2.12.2 Disassembly of oil-gas separator

- 1) Unscrew the two fixing bolts for oil-gas separator bracket;
- 2) Disassemble the hose clips between the oil-gas separator and the pre-separator;
- 3) Disassemble the hose clips on the oil return pipe and escape pipe of oil-gas separator.

If further disassembly is necessary, the oil-gas separator can be disassembled according to Figure 4-22.

4.2.12.3 Inspection and maintenance of oil-gas separator

- 1) Check the appearance of various parts for damages, cracks, etc. and hose for hardening, fragmentation and other failure modes; if the above problems exist, then the affected parts should be replaced;
- 2) Whether the oil-gas separator is obstructed can be checked by charging air into the intake pipe of pre-separator; if the air flow is not free, then we can connect the high pressure air to various pipe joints of

oil-gas separator to eliminate all impurities and greasy dirt in the oil-gas separator. If through the above operations, the pre-separator remains obstructed, then the pre-separator shall be replaced.

3) Whether the oil-gas separator is obstructed can be checked by charging air into the intake pipe of oil-gas separator; if the air flow is not free, then we can disassemble the oil-gas separator and clean the filter screen therein. If through the above operations, the oil-gas separator remains obstructed, then the oil-gas separator shall be replaced.

4.2.12.4 Assembly of oil-gas separator

The assembly procedure of oil-gas separator is in reverse order to that of disassembly. Make sure the positions of various hoses and joints are correct as per Figure 4-22. At the same time, make sure that the installed angle of hoses is correct and their fixed position is conform to the diesel engine.

4.2.13 Disassembly and assembly of oil dipstick

4.2.13.1 Exploded view of oil dipstick

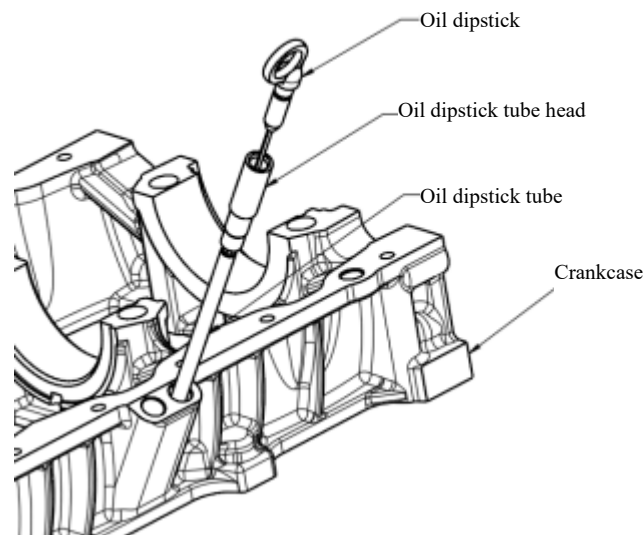

Figure 4-23 Exploded view of oil dipstick

4.2.13.2 Disassembly of oil dipstick

- 1) Pull out the oil dipstick;
- 2) Disassemble the oil dipstick tube;
- 3) Separate the oil dipstick tube head and oil dipstick.

4.2.13.3 Inspection and maintenance of oil dipstick

- 1) When installing, check if the O-ring of oil dipstick comes off;
- 2) To ensure that the oil level is correct, the oil dipstick tube shall be extended below the oil level, without leaving a space. After fixing the oil dipstick tube as required, check if the oil dipstick can be easily pushed in/pulled out.

4.2.13.4 Assembly of oil dipstick

The assembly procedure of oil dipstick is in reverse order to that of disassembly.

4.2.14 Disassembly and assembly of oil filling pipe

4.2.14.1 Exploded view of oil filling pipe

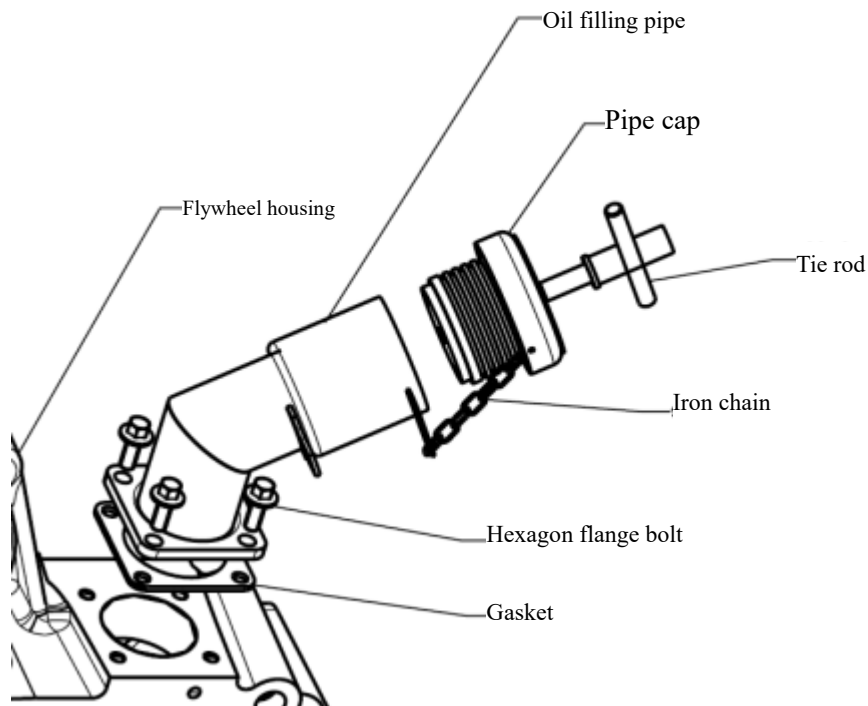

Figure 4-24 Exploded view of oil filling pipe

4.2.14.2 Disassembly of oil filling pipe

- 1) Unscrew the hexagon flange bolts for the oil filling pipe, and remove the oil filling pipe;
- 2) Disassemble the gasket;
- 3) Rotate the tie rod anticlockwise to pull out the pipe cap; and disassemble the oil filling pipe and the pipe cap.

4.2.14.3 Inspection and maintenance of oil filling pipe

- 1) After filling oil, rotate the tie rod clockwise to tighten the pipe cap;

4.2.14.4 Assembly of oil filling pipe

The assembly procedure of oil filling pipe is in reverse order to that of disassembly.

4.2.15 Disassembly and assembly of air bleeder

4.2.15.1 Exploded view of air bleeder

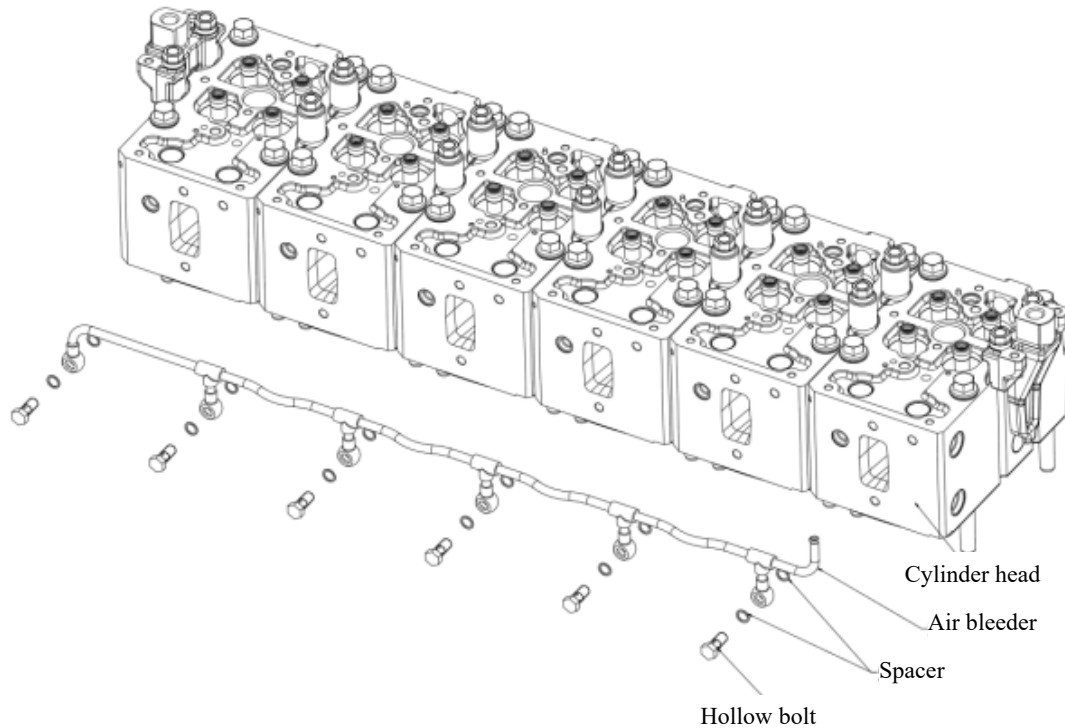

Figure 4-25 Exploded view of air bleeder

4.2.15.2 Disassembly of air bleeder

- 1) Disassemble in sequence the hollow bolts on the air bleeder;
- 2) Take off the air bleeder and spacer.

4.2.15.3 Inspection and maintenance of air bleeder

- 1) Before disassembly, check the air bleeder for sign of water leak, and check the air bleeder for cracks, wear, corrosion and other damages; replace the air bleeder if there are cracks; the causes for corrosion affecting the reliability of diesel engine shall be identified and the air bleeder shall be replaced.
- 2) If there is water leak at various hollow bolts, then we can replace the hollow bolts and spacers and tighten them, then we will check for sign of water leak again.

4.2.15.4 Assembly of air bleeder

- 1) Clean the air bleeder juncture plane;
- 2) Install the spacers onto the hollow bolts;
- 3) Fit the hollow bolt and spacer onto the air bleeder;
- 4) Install the spacer at the other side onto the hollow bolt;
- 5) Fit the air bleeder onto the cylinder head, and tighten in sequence the hollow bolts.

4.3 Crankshaft connecting rod system

4.3.1 Disassembly and assembly of crankshaft connecting rod system

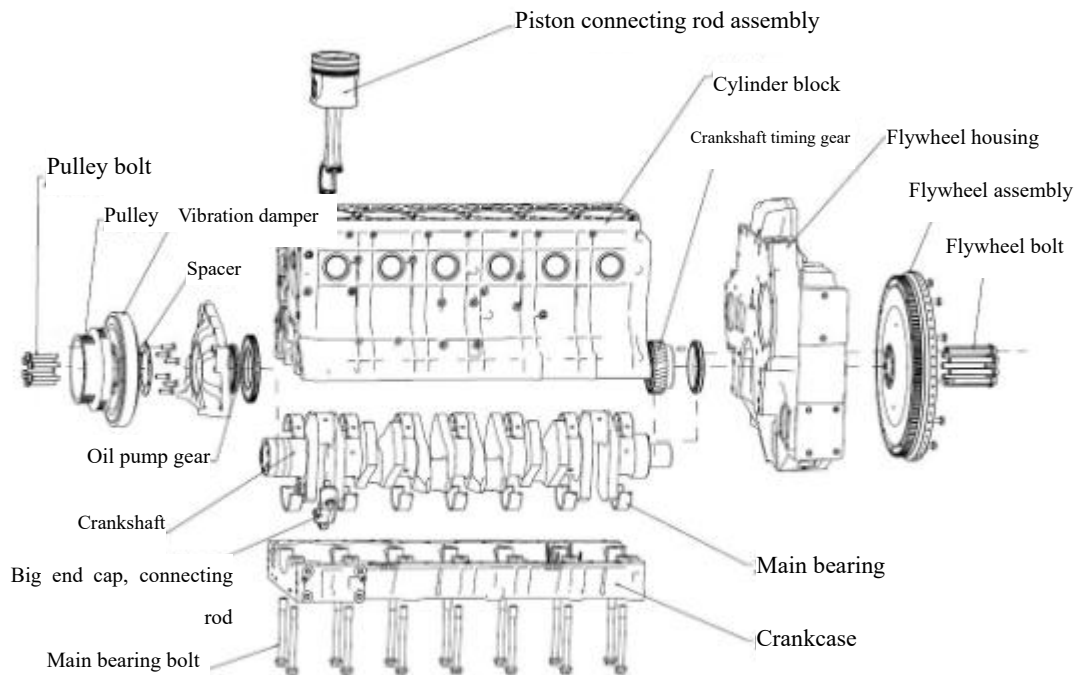

Figure 4-26 Exploded view of crankshaft connecting rod system

4.3.2 Disassembly and assembly of crankshaft flywheel group

4.3.2.1 Disassembly and assembly of crankshaft

4.3.2.1.1 Disassembly of crankshaft

- 1) Place the engine crankcase with the main bearing cap facing upward; unscrew the main bearing bolts and store them in sequence.
- 2) Unscrew the flywheel bolts and remove the flywheel and bearing at flywheel end; take out the front and rear thrust plates and oil seals; unscrew the bolts for belt pulley at front end, and take out the belt pulley and vibration damper. Place the crankshaft on a support (the crankshaft shall be placed vertically if it will be stored for a long time).
- 3) Store all disassembled parts by category as required.

4.3.2.1.2 Check and maintenance of crankshaft

- 1) Check if the fillets of main journal and connecting rod journal of crankshaft are cracked; check the junction between crankshaft and bearing; check the oil passage for abnormalities like cracks.
- 2) Check the wear on main journal and connecting rod journal for wear, line shaped wear, metal spalling and cracks.
- 3) Check the wear on the oil seals.

- 4) Check the main bearing bolts for failure modes like thread failure.
- 5) Check the bolt holes in flange face of crankshaft for cracks.
- 6) Check the crankshaft journal for wear, bend and distortion.

4.3.2.1.3 Assembly of crankshaft

- 1) Place the crankshaft on support frame. Impact damage shall be avoided.
- 2) Knock straight pin into pinhole at rear end of crankshaft.
- 3) Heat the oil pump gear for 10s, and then press fit it into the front end of crankshaft. Make sure that the distance between the outer end face of gear and front end face of crankshaft is in range of (26.5 ± 0.3) mm.
- 4) Check the fitting surfaces of crankshaft for impact damages; eliminate or replace it if necessary. Clean the cavity of oil duct with compressed air. Make sure that the oil duct is clean and unobstructed.
- 5) Grind the lower plane of cylinder block, and remove oil with cleaner, and then wipe it with a towel.
- 6) Make sure that the cylinder block junction surface is clean and free of burrs.
- 7) Clean with cleaner and wipe with a towel the main bearing hole of cylinder block, and then press fit the upper bearing of main bearing into the bottom hole.
- 8) Lift the crankshaft assembly, and clean the oil duct with compressed air and clean the main journal and connecting rod journal with a towel; then lower the crankshaft slowly into the cylinder block, and lower the main journal into the bearing shell.
 - ① Before assembling the crankshaft, lubricate the upper bearing with oil.
 - ② Before assembling, check carefully the friction pairs of crankshaft for impact damages, and eliminate them if necessary.
 - ③ When lifting and assembling, impact damages are strictly prohibited.
 - ④ Before assembling, make sure that the oil gallery holes and friction pairs are clean and tidy.
- 9) Fit two upper thrust plates; make sure that the oil grooves of thrust plates face outward (facing the crankshaft). Before fitting in the thrust plates, the junction surface between the thrust plate and the bearing cap shall be coated with oil.
- 10) The main journals shall be applied with clean lubricating oil.
- 11) The lower plane of cylinder block shall be coated with sealant, with the sealant line continuous and even. While maintaining the oil seal flat, without distortion or deformation, place it horizontally into the seal groove in the lower plane of cylinder block with special tooling.
- 12) Press fit the lower bearing shell and lower thrust plate (with the oil groove facing crankshaft side) into the crankcase and install the crankcase.
- 13) Apply clean lubricating oil onto the bolt supporting surface of crankcase and threads of main bearing bolts; loosen the main bearing bolts, and then pre-tighten all the main bearing bolts in sequence shown in the following figure.

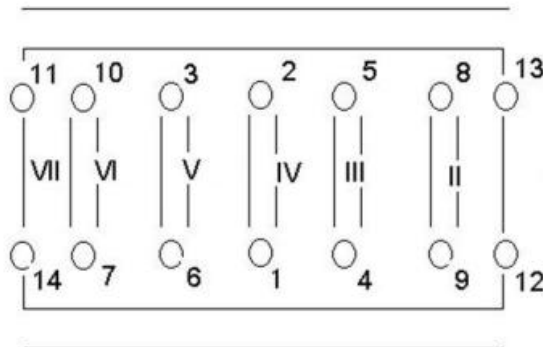

Figure 4-27 Tightening sequence of main bearing bolts

① First tighten it slightly, and then pre-tighten it to (80 ± 5) Nm, then tighten it to (140 ± 5) Nm, and at last rotate by three $(70\pm5)^\circ$ to complete the installation of crankshaft.

14) Measure the axial clearance of crankshaft which shall normally be $(0.06-0.25)$ mm.

4.3.2.2 Disassembly and assembly of crankshaft bearing shell

4.3.2.2.1 Exploded view of crankshaft bearing shell

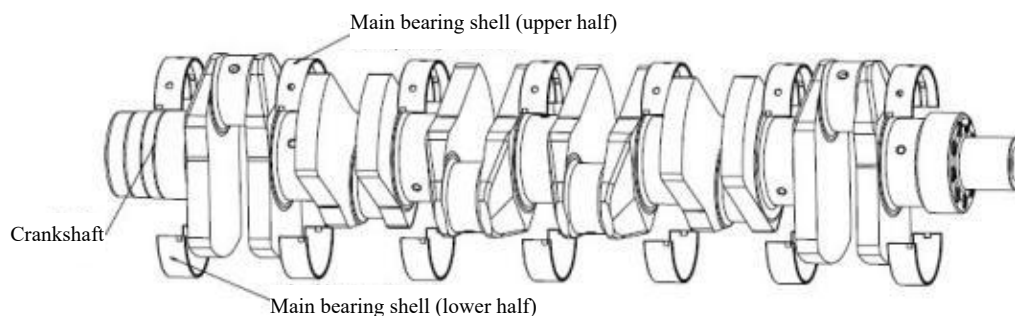

Figure 4-28 Exploded view of crankshaft bearing shell

4.3.2.2.2 Disassembly of crankshaft bearing shell

Push out by hand the bearing shell from one side, and mark the disassembled bearing shell corresponding to the saddle bore in the engine block and the crankcase.

4.3.2.2.3 Inspection and maintenance of crankshaft bearing shell

- 1) Clean the bearing shell and check it for wear.
- 2) Check the bearing shell for metal spalling, locating lip damage and transverse cracks.

4.3.2.2.4 Assembly of crankshaft bearing shell

- 1) First clean the main bearing shell and bottom hole and wipe them up.
- 2) If the bearing shells are not replaced, when assembling, fit the bearing shells into cylinder block (upper bearing) and crankcase (lower bushing), respectively, according to sequence of disassembly; be careful to

distinguish the upper half and lower half of bearing shell, the one with oil groove is upper half; if new bearing shells are used, install them directly. When installing, be sure to align the lips and apply a small amount of oil.

4.3.2.3 Disassembly and assembly of flywheel and gear ring

4.3.2.3.1 Exploded view of flywheel

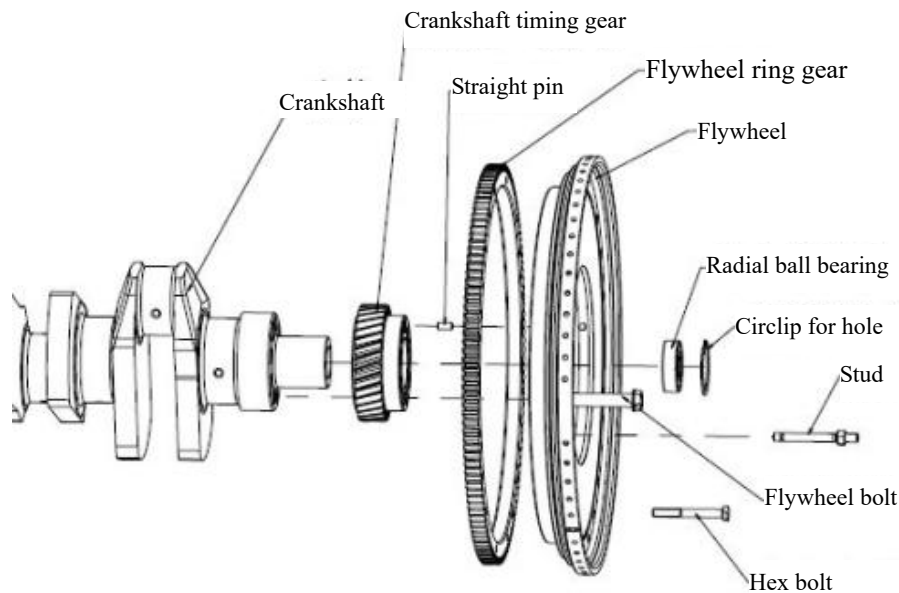

Figure 4-29 Exploded view of flywheel

4.3.2.3.2 Disassembly of flywheel

The disassembly procedure is in reverse order to that of assembly.

4.3.2.3.3 Inspection and maintenance of flywheel

- 1) Check the flywheel bolts for failures like thread failure.
- 2) Check the flywheel surface for crushing.
- 3) Check if the flywheel ring gear is damaged.

4.3.2.3.4 Assembly of flywheel

- 1) Fasten the flywheel ring gear and the flywheel with hex bolts.
- 2) Fit the rear oil seal of crankshaft onto the crankshaft gear, and press fit the rear oil seal with special tooling.
- 3) Knock the straight pin down to the timing gear of crankshaft.
- 4) After the flywheel guide rod is inserted into the bolt hole of crankshaft, install the flywheel assembly, and pre-tighten the flywheel bolts diagonally. Lubricate the threads and bearing surfaces of flywheel bolts.
- 5) Tighten the flywheel bolts.

There are nine flywheel bolts (M14×1.5). Tightening by hand: After lubricating the threads and bearing surfaces of flywheel bolts with oil, install the bolts into the threaded holes and tighten them diagonally with tightening torque of 105_0^{+20} Nm, and then rotate by $270^\circ \pm 5^\circ$.

6) Replace any flywheel bolts which cannot meet the torque requirements after rotating by the specified angle.

4.3.3 Disassembly and assembly of piston and connecting rod mechanism

4.3.3.1 Disassembly and assembly of piston and connecting rod group

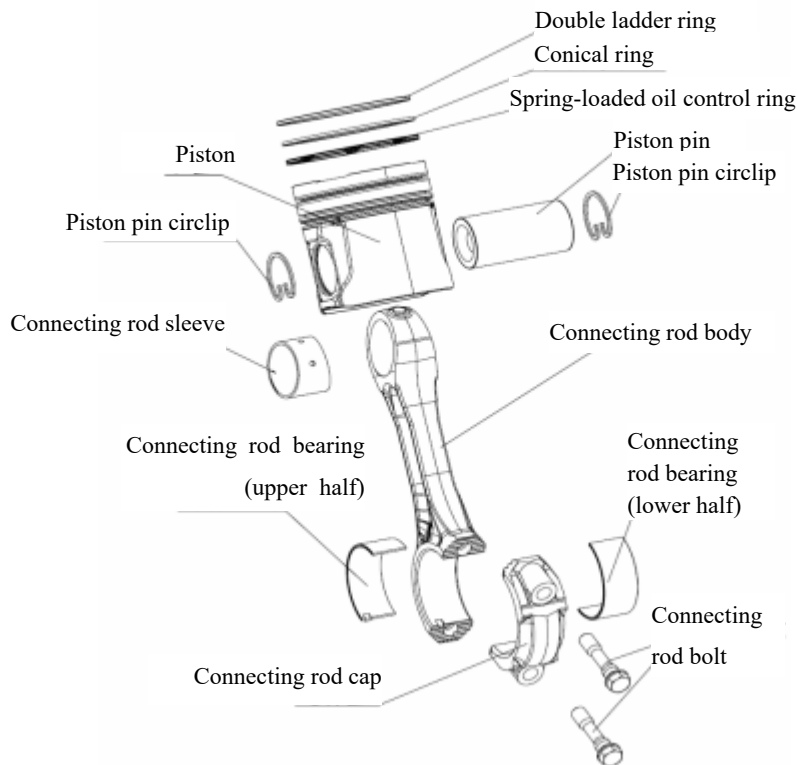

Figure 4-30 Exploded view of piston and connecting rod group

4.3.3.1.1 Disassembly of piston and connecting rod group

Be careful to clear the carbon deposition on top of cylinder so as not to damage the interior of the cylinder liner. Incline the engine and rotate the flywheel until the piston reaches the BDC, and disassemble the connecting rod bolts and connecting rod cap. Rotate the flywheel to make the piston at TDC, and knock out the piston with a wood hammer. Operate carefully not to have the connecting rod big end stuck by the cylinder liner. Place the bearing shell and connecting rod cap in their original sequence.

4.3.3.1.2 Assembly of piston and connecting rod group

- 1) Install a circlip for hole into the circlip groove with an internal circlip pliers, and rotate the circlip to ensure that it is completely installed.
- 2) Insert the connecting rod small end into the piston cavity, and align the small end with the piston pin hole, and then insert the piston pin, and finally insert the piston pin circlip at the other side. The opening of circlip should be 30° off the piston centerline, and the two rings should stagger by 60° . Make sure that the direction of oblique parting face of connecting rod is the same with that of the oil inlet port of piston cooling oil duct; apply proper amount of clean lubricating oil to the hole in connecting rod small end and piston pin before installation.

3) Hang the preassembled piston and connecting rod onto the pallet in sequence of cylinder number; fit the spring-loaded oil control ring, conical ring and double ladder ring into the piston ring grooves in sequence with piston ring mounting pliers. Make sure that the piston rings are installed in the ring grooves in parallel, and they shall not be distorted. The face of piston ring with “TOP” shall be upward, and the rings shall rotate smoothly in the ring grooves.

4) Adjust the direction of ring openings: the opening of the first ring is located with offset angle of 30° from the center line of piston pin; the second ring should stagger by 120° from the opening of the first ring; and the oil control ring should stagger by 120° respectively from the first and second rings, and is at the vertical bisector of center line of piston ring. Refer to the following figure.

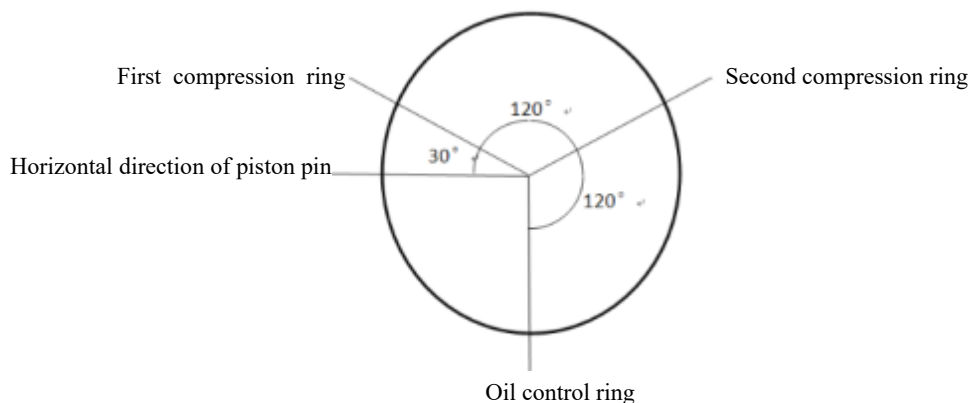

Figure 4-31 Piston ring installation angle

5) Clean the internal of cylinder liner, the crank arm of crankshaft and the piston and connecting rod assembly, and apply clean lubricating oil onto kinematic pairs.

6) Rotate the engine flywheel until the pistons of cylinder 1 and 6 are at BDC, and then while directing the front end of arrow on piston toward the front end of cylinder block, place gently the piston and connecting rod assembly into the cylinder liner. Hold the piston ring compressor closely against the cylinder liner. Push the piston into the cylinder liner with compressor. And then pull down the connecting rod to fit it onto the crankshaft journal.

Tightening of connecting rod bolts:

Tightening by hand: first, tighten slightly, and then tighten symmetrically with tightening torque of 115Nm, and then rotate by $90^\circ \pm 5^\circ$;

Tightening with auto-wrench: first, tighten slightly, and then tighten symmetrically with tightening torque of 80Nm, and then rotate by $153^\circ \pm 5^\circ$.

Make sure that the piston cylinder number is the same with cylinder number, and the connecting rod cap and connecting rod body are used in pairs, and apply clean lubricating oil before fitting the connecting rod bolts. Install the rest cylinders in the same way.

4.3.3.2 Disassembly and assembly of piston

4.3.3.2.1 Disassembly of piston

Carefully disassemble the circlips at both sides of piston pin with internal circlip pliers, and push out the piston pin, and then remove the connecting rod body. Number the pistons according to cylinder number respectively, and put them in order.

Disassemble the first ring, second ring and oil control ring respectively with the piston ring mounting pliers, and mark them respectively.

4.3.3.2.2 Inspection and maintenance of piston

- 1) Check the piston surface and inner cavity, surfaces of piston ring and piston pin for burrs, greasy dirt or impact damages. Check the fillet of throat of combustion chamber and piston pin boss for cracks; replace them if necessary.
- 2) Check the external of piston ring, the upper and lower end faces of piston rings for abnormal worn.
- 3) The weight group character “G” of pistons used in the same engine shall be consistent.
- 4) After the piston rings are installed on the piston, the pistons must not collide with each other.

4.3.3.2.3 Assembly of piston

Fit the piston pin circlip, piston pin and connecting rod body one by one on piston.

4.3.3.3 Disassembly and assembly of connecting rod group

4.3.3.3.1 Exploded view of connecting rod

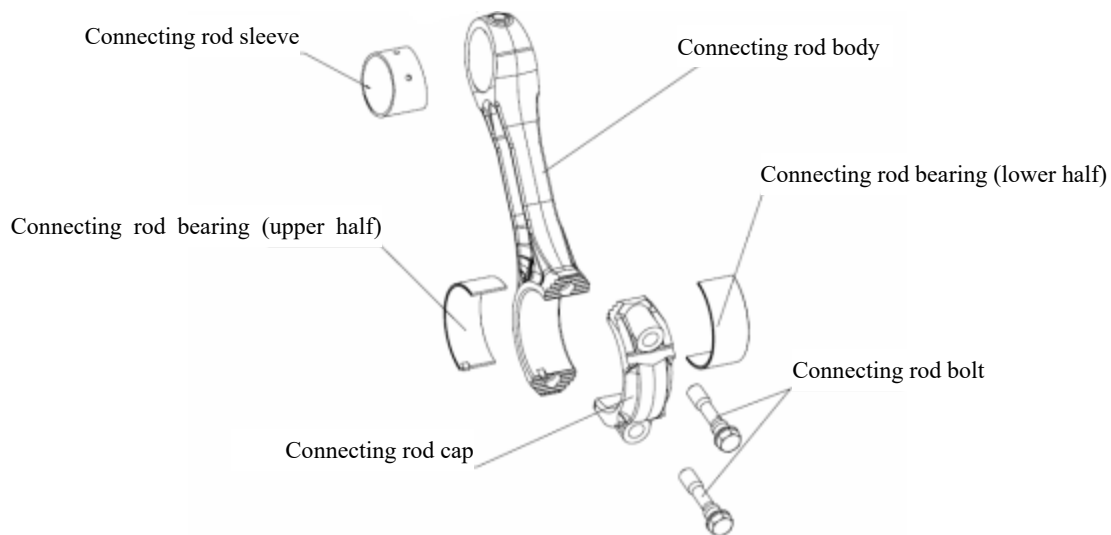

Figure 4-32 Exploded view of connecting rod

4.3.3.3.2 Disassembly of connecting rod

Carefully disassemble the circlips at both sides of piston with internal circlip pliers, and push out the piston pin, and then remove the connecting rod body. Number the connecting rod bodies respectively, and put them in order.

4.3.3.3.3 Inspection and maintenance of connecting rod

- 1) Check the big and small ends of connecting rod for burrs and impact damages, and make sure that there is no crack, deformation or color change around the oil hole in small end bushing.
- 2) Check the side faces of connecting rod for abnormal wear; check whether the connecting rod body is bent.
- 3) Check whether the alloy layer of connecting rod bushing is abnormally worn and there is sign of metal spalling.

- 4) The cylinder number on connecting rod body and connecting rod cap must be consistent; the weight group character “G” of connecting rods used in the same engine shall be consistent.
- 5) If either of the connecting rod body or connecting rod cap is worn or damaged, then both of them shall be replaced altogether.
- 6) If there are crushing damages on the connecting rod body, replace it.
- 7) The connecting rod bolts cannot be reused.

4.3.3.3.4 Assembly of connecting rod

- 1) Press fit connecting rod bushing into special clamping fixture and check the alignment of oil holes.
- 2) Fit the connecting rod bearing into the connecting rod and connecting rod bearing cap, respectively. Make sure that the locating lips of the connecting rod bearings can be fit into the grooves in connecting rod big end and connecting rod cap.
- 3) Insert the connecting rod small end into the piston cavity, and align the small end with the piston pin hole, and then insert the piston pin, and finally insert the piston pin circlip at the other side.

4.3.4 Disassembly and assembly of connecting rod bearing

4.3.4.1 Exploded view of connecting rod bearing

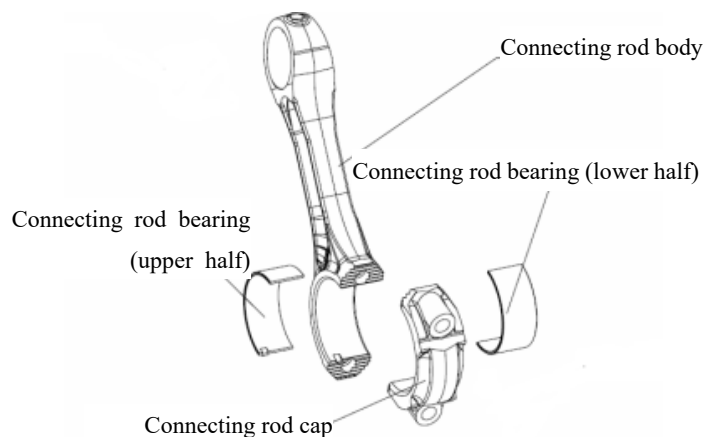

Figure 4-33 Exploded view of connecting rod bearing

4.3.4.2 Disassembly of connecting rod bearing

Apply radial force and tangential force onto connecting rod bearing shell to force the bearing to leave the assembly position, and take out the bearings. Number them according to cylinder number and put them in order.

4.3.4.3 Inspection and maintenance of connecting rod bearing

- 1) Check the appearance of bearing for scuffing damages or burrs.
- 2) Before installing the connecting rod bearing shell, clean the bottom hole and bearing; no lubricating oil is allowed at the bottom hole and the back of bearing.
- 3) If there is corrosion, cavitation erosion, exfoliation corrosion or scratch, the connecting rod bearing shall be replaced.
- 4) Check the wear on connecting rod bearing to see if there is sign of color change, metal spalling, slipping in alloy layer.

4.3.4.4 Assembly of connecting rod bearing

Apply radial force and tangential force onto the connecting rod bearing shell to force the bearing to leave the end face of connecting rod cap and to enable the edge of connecting rod big end enter into the assembly position so as not to cause scratch damage to steel backing. Make sure that the locating lip of the connecting rod bearing shell directly faces the groove in connecting rod big end and connecting rod cap. After installation, make sure to apply lubricating oil to the inner face of bearing.

4.3.5 Disassembly and assembly of vibration damper and crank pulley

4.3.5.1 Exploded view of shock absorber and crank pulley

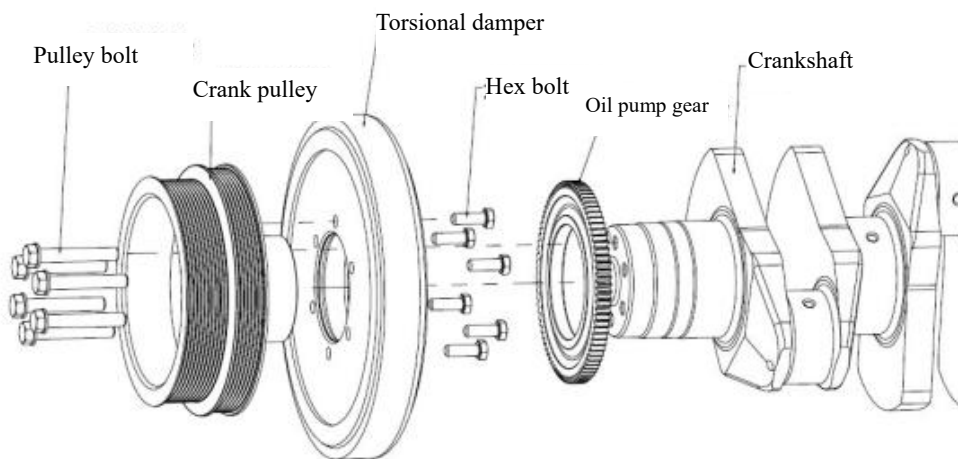

Figure 4-34 Exploded view of vibration damper and crank pulley

4.3.5.2 Disassembly and assembly of vibration damper and crank pulley

Unscrew the pulley bolts, take out the pulley and vibration damper, unscrew the hex bolts, and then take out the crank pulley and torsional vibration damper one by one.

4.3.5.3 Inspection and maintenance of vibration damper and crank pulley

- 1) Check the vibration damper for impact damage, deformation, etc.
- 2) Check if the pulley is damaged, and check the tightening place of pulley for crushing damage.
- 3) Check the pulley bolts for damage.

4.3.5.4 Assembly of vibration damper and crank pulley

After the oil pump gear is installed, first fix the torsional vibration damper and crank pulley together with hex bolts, and then tighten them to the crankshaft flange with pulley bolts.

4.4 Valve train

4.4.1 Disassembly and assembly of valve train

4.4.1.1 Exploded view of valve train

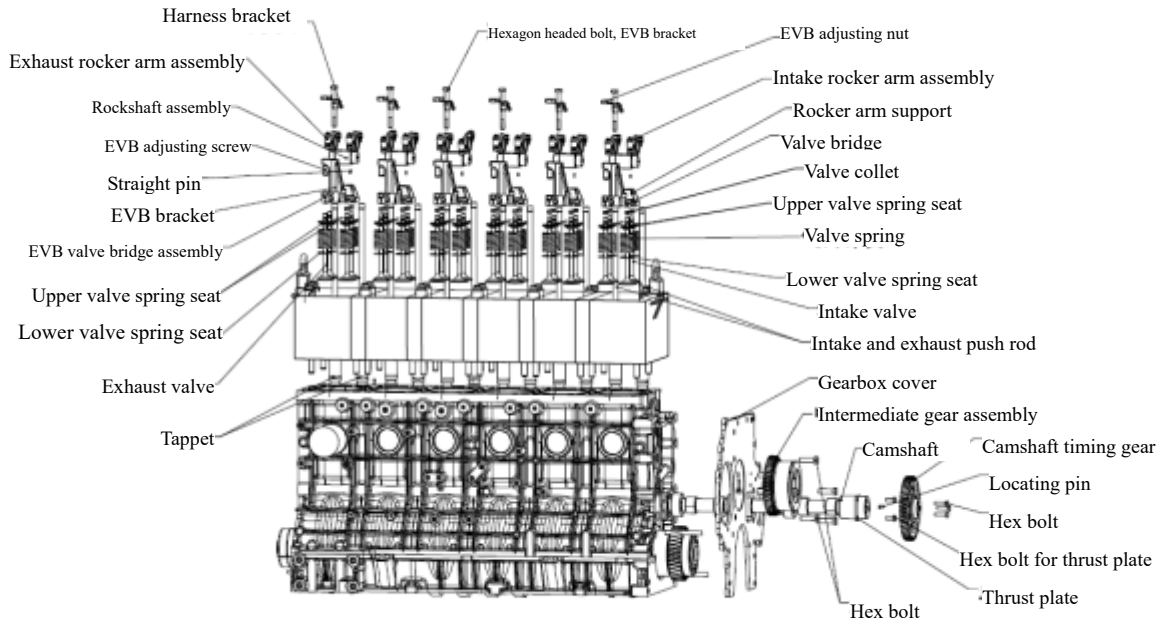

Figure 4-35 Exploded view of valve train

4.4.1.2 Disassembly of valve train

- 1) Disassemble the rocker arm and rockshaft;
- 2) Disassemble the intake and exhaust valves;
- 3) Disassemble the tappet and push rod;
- 4) Disassemble the camshaft and camshaft timing gear;
- 5) Disassemble the intermediate gear.

4.4.1.3 Assembly of valve train

- 1) Assemble the intermediate gear;
- 2) Assemble the camshaft and camshaft timing gear;
- 3) Assemble the tappet and push rod;
- 4) Assemble the intake and exhaust valves;
- 5) Assemble the rocker arm and rockshaft.

4.4.2 Disassembly and assembly of camshaft

4.4.2.1 Exploded view of camshaft

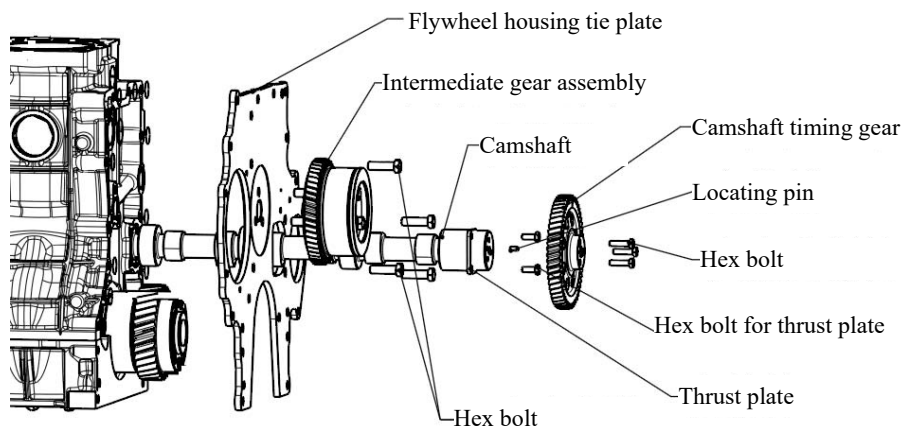

Figure 4-36 Exploded view of camshaft

4.4.2.2 Disassembly of camshaft

- 1) Rotate the camshaft, and check the camshaft and the timing gear for rotate flexible;
- 2) Check the camshaft for axial float with a dial gauge, as compared with the previous;
- 3) Check the backlash of timing gear;
- 4) On the assembly and disassembly workbench for engine, rotate the crankshaft until the camshaft timing gear is at the TDC of the first cylinder. Check if the camshaft fixing bolts are loose; remove the hexagon camshaft bolts, timing gear and locating pin;
- 5) Unscrew the hexagon headed bolts of camshaft thrust plate; disassemble the thrust plate and the camshaft.

4.4.2.3 Inspection and maintenance of camshaft

- 1) Check the cam surface in contact with the tappet for wear; check the main journal for seizing and wear;
- 2) Check if the timing gear bolts are bent or deformed, and check the camshaft timing gear for tooth broken or serious wear.

4.4.2.4 Assembly of camshaft

After disassembling, check the camshaft and timing gear; in case of wear or big deviation in other parameters, the camshaft shall be repaired or replaced.

- 1) Wipe the camshaft hole with a towel, check the camshaft hole for impact damages, and then apply appropriate amount of lubricating oil inside the camshaft bush with an oil can. If there are damages in the camshaft hole, the camshaft cannot be used after repair.
- 2) Fit the camshaft guide tool and camshaft sliding sleeve into the camshaft hole, clean the camshaft and check it for impact damages; align the cylinder at the end of guide tooling with the cylinder at head of camshaft, and then put the camshaft through the camshaft hole; after the camshaft is installed, take out the camshaft guide tool and camshaft sliding sleeve. When fitting in the camshaft, take special care to avoid damage to camshaft bush.

- 3) Install the camshaft thrust plate. Apply clean lubricating oil on both sides of camshaft thrust plate, rotate the camshaft, which shall rotate freely; apply Loctite 242 sealant to threads of thrust plate bolts, and the tightening torque shall be (35 ± 3) Nm.
- 4) Grind the rear end face of cylinder block, remove oil from it and then clean it; the junction surface shall be flat and clean; knock the straight pin into the rear end face of crankshaft, after that fit the flywheel housing tie plate and then tighten the four fastening bolts.
- 5) Apply special sealant onto the tie plate, and the sealant line should be continuous and even.
- 6) Tighten the camshaft thrust plate and timing gear onto the camshaft with bolts, the counter bore in tie plate must be aligned with the marked teeth of camshaft timing gear.

4.4.3 Disassembly and assembly of rocker arm and rockshaft

4.4.3.1 Exploded view of rocker arm and rockshaft

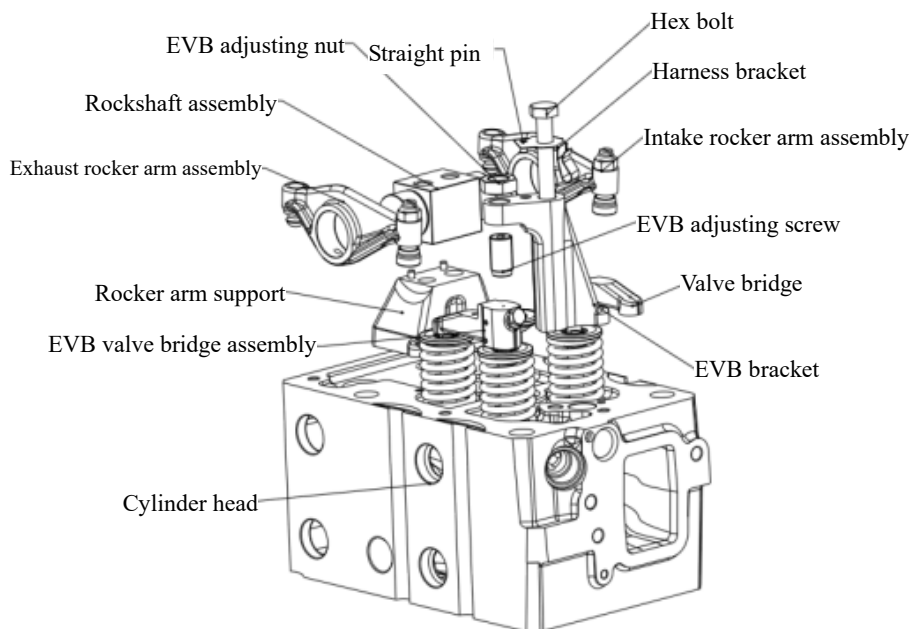

Figure 4-37 Exploded view of rocker arm and rockshaft

4.4.3.2 Disassembly of rocker arm and rockshaft

- 1) Rotate the crankshaft to see if the rocker rotates freely.
- 2) Measure various valve clearances and check their changes.
- 3) If the rocker arm cannot rotate freely or if the valve clearances change dramatically, loosen the hex head screws and gently take out the EVB support, rockshaft assembly, intake and exhaust rocker arm and rocker arm support; mark them in order not to confuse.

4.4.3.3 Inspection and maintenance of rocker arm and rockshaft

- 1) Clean the rocker arm, and check its appearance for defects like cracks.
- 2) Check the rocker arm bore for wear and scratch, and measure its diameter.

- 3) Check the sphere-pin and rocker arm for wear.
- 4) Check if various oil passages are blocked.
- 5) Measure the diameters of the rocker arm hole and rockshaft, and calculate the fit clearance.
- 6) Check the wear on EVB adjusting screw, and check the EVB support for cracks or wear.

4.4.3.4 Assembly of rocker arm and rockshaft

- 1) Place the rocker arm on the operating platform, screw the adjusting screw onto the rocker arm and install the nut for inspection;
- 2) Fit straight pin into the pinhole in lower plane of rocker arm shaft completely; the straight pin should be free of cracks;
- 3) Tighten the hex head screws in two M5 bolt holes on both sides of rocker arm shaft; for screws without precoating sealant, Loctite 271 sealant shall be applied; after the screws are fit, the screw head shall be (0-1) mm deeper than the side face of rocker arm shaft;
- 4) Assemble the rocker arm support and the rocker arm shaft together; the two parts shall be bond tightly; apply a small amount of lubricating oil onto the rocker arm shaft and then fit the rocker arm assembly, which shall be able to rotate freely; fit two hex bolts into the rocker arm shaft seat;
- 5) Knock straight pin into the pinhole in upper plane of EVB support completely; screw the adjusting screw into the EVB support and install the EVB adjusting screw without tightening;
- 6) Install the harness support for fuel injectors onto the EVB support and insert the hex bolts, and the harness support for fuel injector shall be set with locating pin;
- 7) After the valve push rod is installed, place the valve bridge and EVB valve bridge assembly onto the intake and exhaust valves respectively;
- 8) Fit the rocker arm assembly and pre-tighten it; the pinhole at underside of rocker arm support shall be aligned with the locating pin in upper plane of cylinder head and be fit in place; fit the rocker arm sphere-pin into the round hole of valve push rod;
- 9) Install the EVB support assembly and pre-tighten it; The pinhole at underside of EVB support shall be aligned with the locating pin in upper plane of cylinder head and be fit in place;
- 10) Tighten the bolt to rocker arm bracket; tighten the hold-down bolt to EVB support;
- 11) Check and adjust the intake and exhaust valve clearances;
- 12) Rotate the engine flywheel to TDC of cylinder 1, that is, when the scale mark on flywheel is aligned with the scale mark on flywheel housing, from which we can judge the compression stroke TDC of cylinder 1;
- 13) Adjust the intake valve clearances of cylinders 1, 2 and 4, and the exhaust valve clearances of cylinders 1, 3 and 5; the intake valve clearance shall be (0.38 ± 0.03) mm; the exhaust valve clearance shall be (0.58 ± 0.03) mm, and the EVB clearance shall be (0.38 ± 0.03) mm; The tightening torque of adjusting nuts of intake and exhaust valves shall be (45 ± 5) Nm; the tightening torque of EVB nut shall be $(50-65)$ Nm;
- 14) The exhaust valve clearance shall be adjusted as follows:

Fully loosen the EVB adjusting screw, adjust the locknut and adjusting screw for exhaust valve clearance, adjust the exhaust valve clearance to (0.58 ± 0.03) mm; insert a feeler gauge below the EVB adjusting screw and adjust

the EVB clearance to (0.38 ± 0.3) mm; then the piston in the EVB valve bridge shall be fully compressed to bottom.

15) Install the fixing device for engine barring onto the flywheel housing and tighten two hexagon nuts at outer side, and the rotate the engine flywheel to TDC of cylinder 6;

16) Adjust the intake valves of cylinders 3, 5 and 6 and exhaust valve clearance of cylinders 2, 4 and 6. The piston of cylinder 6 shall be at the TDC. The intake valve clearance shall be (0.38 ± 0.03) mm; the exhaust valve clearance shall be (0.58 ± 0.03) mm, and the EVB clearance shall be (0.38 ± 0.03) mm;

17) Check at cold state the valve timing of cylinder 1: the intake valve is open at $(20\pm 5)^\circ$ before TDC, and exhaust valve is close at $(21\pm 5)^\circ$ after TDC.

4.4.4 Disassembly and assembly of tappet and push rod

4.4.4.1 Exploded view of tappet and push rod

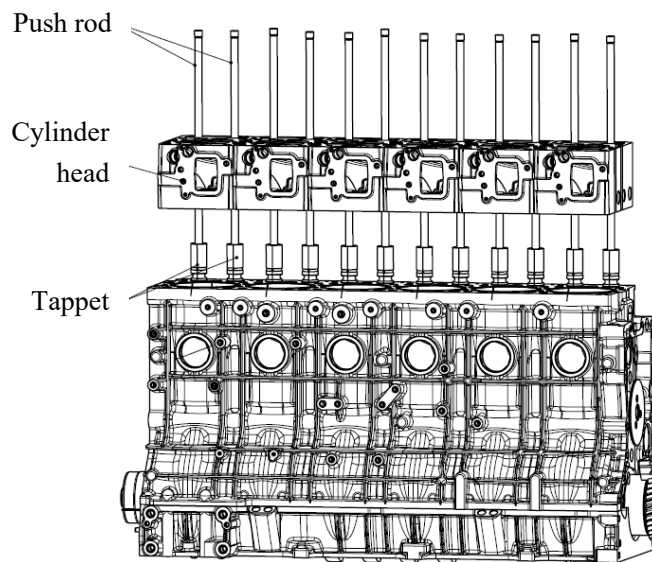

Figure 4-38 Exploded view of tappet and push rod

4.4.4.2 Disassembly of tappet and push rod

- ① After disassembling the rocker arms and the rockshafts, remove the push rods directly and place them in order.
- ② After disassembling the cylinder head (see the disassembly of cylinder head for details), remove the tappets and place them in order.

4.4.4.3 Inspection and maintenance of tappet and push rod

- ① Clean the tappets and push rods;
- ② Check the oil passages of tappet and push rod for smoothness;
- ③ Check the push rods for deformation and check the surface for abrasion;
- ④ Check the ball joint and concave end of push rod for abrasion;
- ⑤ Check the surface and bottom of tappet for abrasion;

- ⑥ Check the internal concave end of tappet for abrasion.

4.4.4.4 Assembly of tappet and push rod

- ① Check the tappets and push rods for any abnormality and replace when necessary. Before assembling the tappet, clean them with compressed air and check the oil hole for smoothness.
- ② Apply clean lubricating oil evenly on the outer ring and bottom of valve tappet;
- ③ Install tappet into tappet hole with special installation tools and no damages shall be made on tappet and tappet hole during installation;
- ④ After assembling cylinder head (see the assembly of cylinder head for details), clean the push rod with compressed air and check the oil hole for smoothness;
- ⑤ Apply clean lubricating oil on push rod and a sufficient amount of lubricating oil must be applied on the ball head and the concave end;
- ⑥ Install push rod with the ball joint facing downwards.

4.4.5 Disassembly and assembly of valve

4.4.5.1 Exploded view of valve

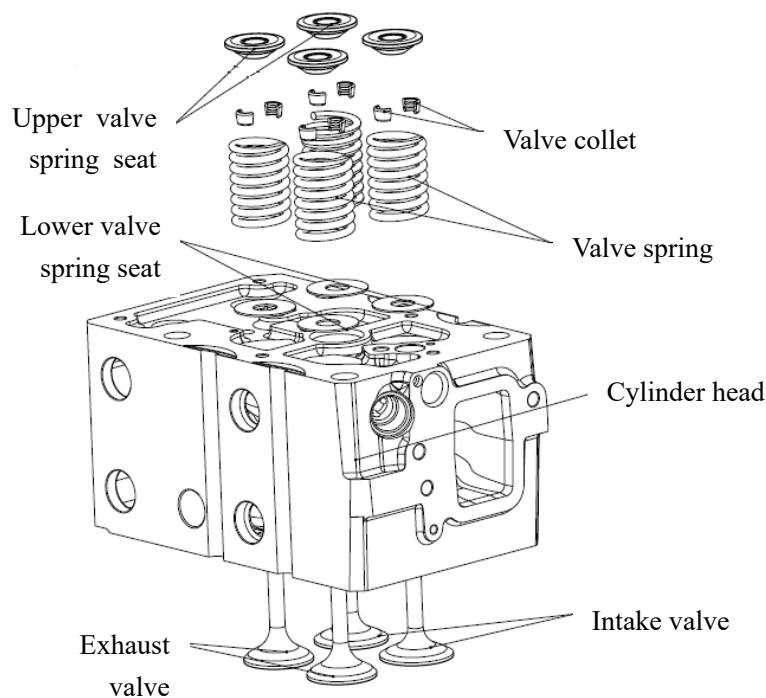

Figure 4-39 Exploded view of valve

4.4.5.2 Disassembly of valve

- ① Compress the valve springs with valve spring compressor, valve spring pliers or other tools, take out the valve collets and remove upper valve spring seat and internal and external valve springs.
- ② Remove the valves from valve seats.

4.4.5.3 Inspection and maintenance of valve

- ① Check the valve rod and its end surface for abrasion.
- ② Check the valve cone for abrasion or damage.
- ③ Check the valve cone for carbon deposit.
- ④ Check the end surface of valve disc for carbon deposit or sintering.

4.4.5.4 Assembly of valve

The valve shall be replaced in case of abrasion, carbon deposit or severe sintering etc.

- ① Apply molybdenum disulfide evenly on the rods of intake and exhaust valves, install the intake and exhaust valves in cylinder head to make sure that the intake and exhaust valves can move smoothly in the valve guide.
- ② Install three locating pins completely in the upper surface of every cylinder head.
- ③ Install the lower valve spring seat, place protective sleeves for valve rod on the valve guides of intake and exhaust valves and then install the valve rod seal cartridges;

Notes: The internal spring of valve rod seal cartridge must be checked for intactness before assembling.

- ④ Install the valve spring.
- ⑤ Install the upper valve spring seat, compress the valve spring and install the valve collets.
- ⑥ After assembling the valve collets, tap the intake and exhaust valves with rubber hammer to make sure correct installation. For valve collet or upper valve spring seat which is not installed in place, find out the causes and install again.

4.4.6 Disassembly and assembly of intermediate gear

4.4.6.1 Exploded view of intermediate gear

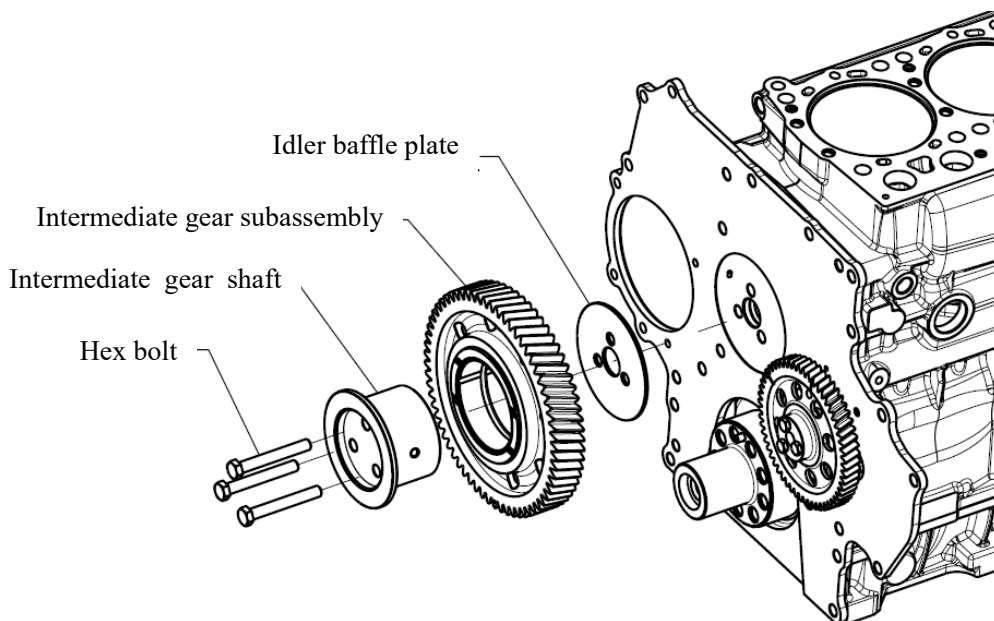

Figure 4-40 Exploded view of intermediate gear

4.4.6.2 Disassembly of intermediate gear

- ① Check the mounting marks of intermediate gear bolts, and confirm whether the bolts has moved.

② Unscrew the three M12 hex bolts of intermediate gear, remove the intermediate gear subassembly, intermediate gear shaft and idler baffle plate together with the three bolts and prevent the idler baffle plate falling down.

4.4.6.3 Inspection and maintenance of intermediate gear

- ① Check the threads of mounting bolts for intactness.
- ② Check every gear for metal flaking and breakage; Check the bearing surface of bolt for crushing and check the threaded or through holes on gear for deformation.
- ③ Check the shaft and the bushing of intermediate gear for abnormal abrasion and every oil hole for blockage.

4.4.6.4 Assembly of intermediate gear

- ① Before assembly, check the intermediate gear subassembly, intermediate gear shaft, hex bolts and idler baffle plate for manufacturing and use defects and damages.
- ② Install the flywheel housing connecting plate and the camshaft timing gear, rotate the camshaft timing gear to make the pinhole on gear web aligned with the pinhole on flywheel housing connecting plate and install the pin for locating. At this time, one groove of gear surface shall align with the counterbore of flywheel housing connecting plate.
- ③ Install two studs in flywheel housing connecting plate and install the idler baffle plate.
- ④ The intermediate gear subassembly is made of a large gear and a small gear through hot installation and located by pins. Insert the intermediate gear shaft into the hole of intermediate gear subassembly from the large gear side, locate and install it with studs, screw out the studs, install and tighten the M12 hex bolts. The timing mark of large gear shall align with that of camshaft timing gear (the outer ring groove of inner hub of the large gear shall align with the other groove on the teeth surface of the camshaft timing gear).

4.5 Intake and exhaust system

4.5.1 Disassembly and assembly of intake and exhaust system

4.5.1.1 Exploded view of intake and exhaust system

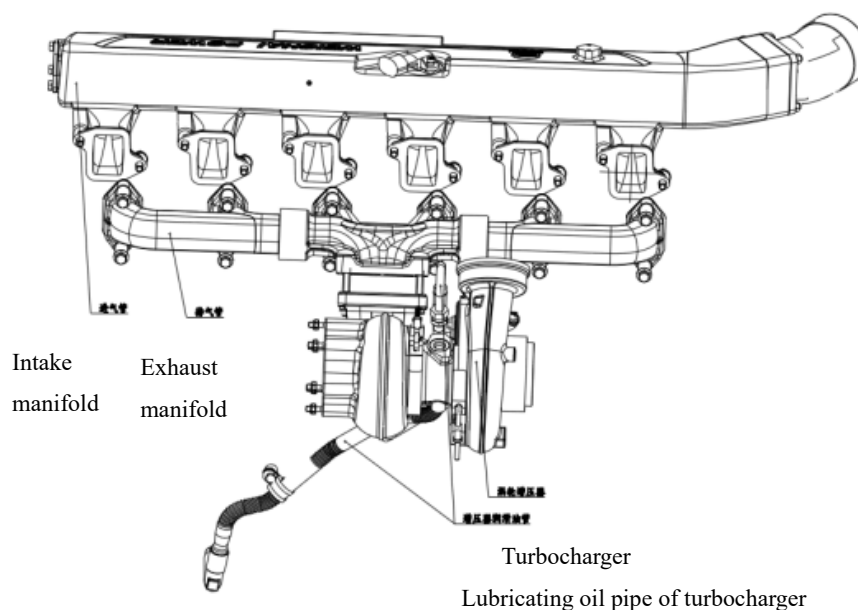

Figure 4-41 Exploded view of intake and exhaust system

4.5.1.2 Disassembly of intake and exhaust system

- 1) Disassemble the lubricating oil pipe of turbocharger
- 2) Disassemble the turbocharger
- 3) Disassemble the exhaust manifold
- 4) Disassemble the intake manifold

4.5.1.3 Assembly of intake and exhaust system

The assembly procedure is in reverse order to that of disassembly.

4.5.2 Disassembly and assembly of intake manifold

4.5.2.1 Exploded view of intake manifold

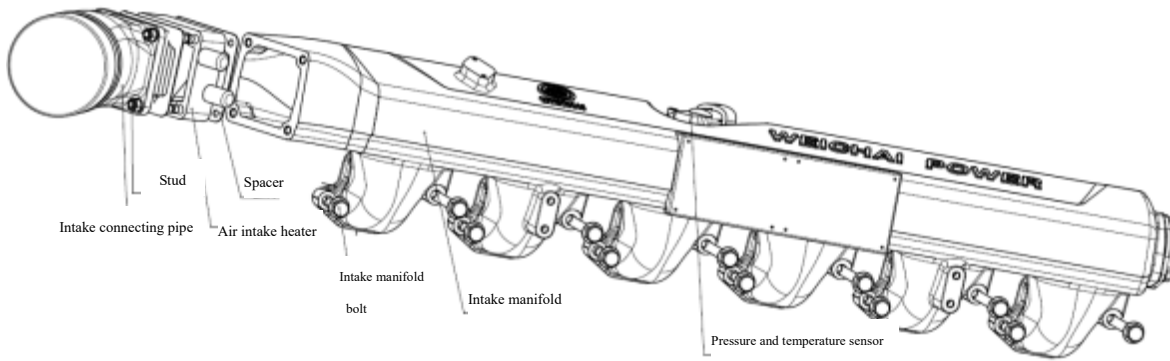

Figure 4-42 Exploded view of intake manifold

4.5.2.2 Disassembly of intake pipe

- 1) Disassemble the intake connecting pipe;
- 2) Disassemble the air intake heater;
- 3) Disassemble the intake manifold bolts;
- 4) Disassemble the intake manifold;
- 5) Disassemble the spacer of intake manifold.

4.5.2.3 Inspection and maintenance of intake manifold

- a) Inspection of pressure and temperature sensor

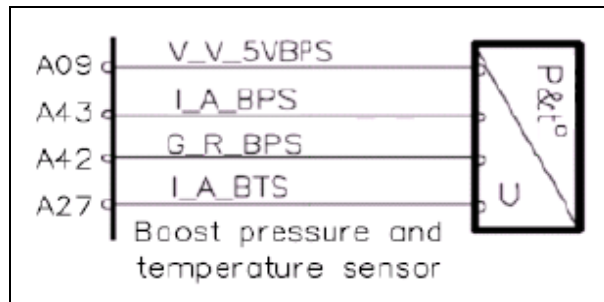

Figure 4-43 ECU pin diagram

Check and measure the harness connection of intake pressure and temperature sensor and the sensor for damages and anomalies.

b) Inspection of intake pipeline

The engine intake pipeline shall be kept unblocked; check if there are cracks, etc. in the intake manifold; if necessary, tighten the intake pipeline and ensure the tightness of intake system. Check if the intake heater is in good condition.

4.5.2.4 Assembly of intake manifold

The assembly procedure is in reverse order to that of disassembly.

4.5.3 Disassembly and assembly of exhaust manifold

4.5.3.1 Exploded view of exhaust manifold

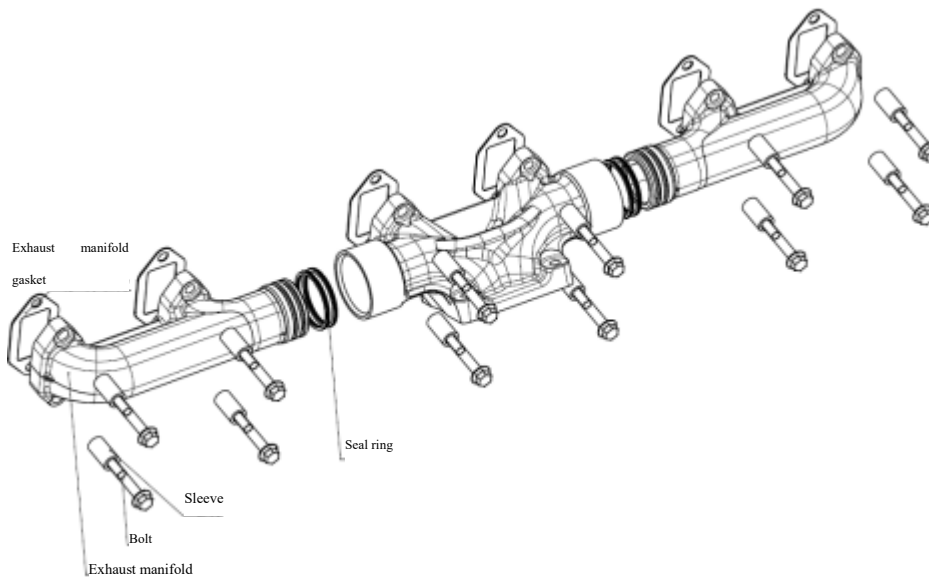

Figure 4-44 Exploded view of exhaust manifold

4.5.3.2 Disassembly of exhaust manifold

- 1) Disassemble the exhaust manifold bolts;
- 2) Disassemble the sleeve;
- 3) Disassemble the exhaust manifold;
- 4) Disassemble the gasket of exhaust manifold;
- 5) Disassemble the exhaust manifold seal ring

4.5.3.3 Inspection and maintenance of exhaust manifold

Check if the exhaust manifold is blocked and if the bolts (heat-resistant bolts) are loose, and if there are cracks or leak in the exhaust manifold.

4.5.3.4 Assembly of exhaust manifold

The assembly procedure is in reverse order to that of disassembly. The seal rings shall be installed with their openings staggered 180°.

4.5.4 Disassembly and assembly of turbocharger

4.5.4.1 Exploded view of turbocharger

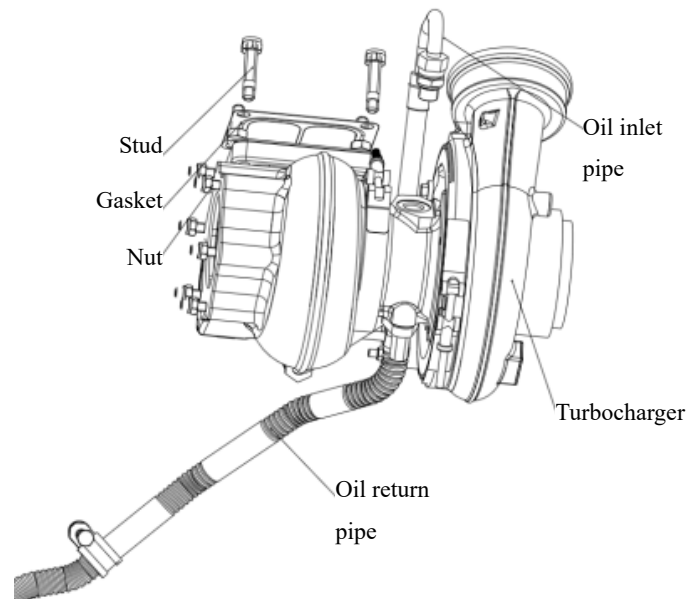

Figure 4-45 Exploded view of turbocharger and lubricating oil pipe

4.5.4.2 Disassembly of turbocharger

- 1) Disassemble oil return pipe of turbocharger
- 2) Disassemble oil inlet pipe of turbocharger
- 3) Disassemble the turbocharger

4.5.4.3 Inspection and maintenance of turbocharger

- 1) Check the connection between the turbocharger and the engine piping, and tighten it if necessary;
- 2) Check the turbocharger for gas and oil leak, and remove it immediately, if any;
- 3) Check the turbocharger fastening screws for looseness and remove any fault immediately, if any;
- 4) Check the air filter, and clean it if there is excessive dust.

When disassembly the turbocharger, if there is any failure that cannot be eliminated, then the turbocharger shall be delivered to our production or service department for troubleshooting.

- 5) Unscrew the fastening screws of compressor volute casing, gently shake the compressor volute casing around the impeller, and knock the casing outward evenly with a rubber hammer. Take care to prevent the casing from colliding with the impeller blade, and the shaft end nut shall not be loosened.
- 6) Remove the oil dirt from the impeller passage and casing cavity with petrol.
- 7) When reinstalling the compressor volute casing, tighten the fastening screws as per specifications, and the tightening torque shall be 15 Nm.

Notice: If it is necessary to disassemble the shafting assembly, please seek help from professionals or Weichai Power.

4.5.4.4 Assembly of turbocharger

The assembly procedure is in reverse order to that of disassembly.

4.6 Fuel system

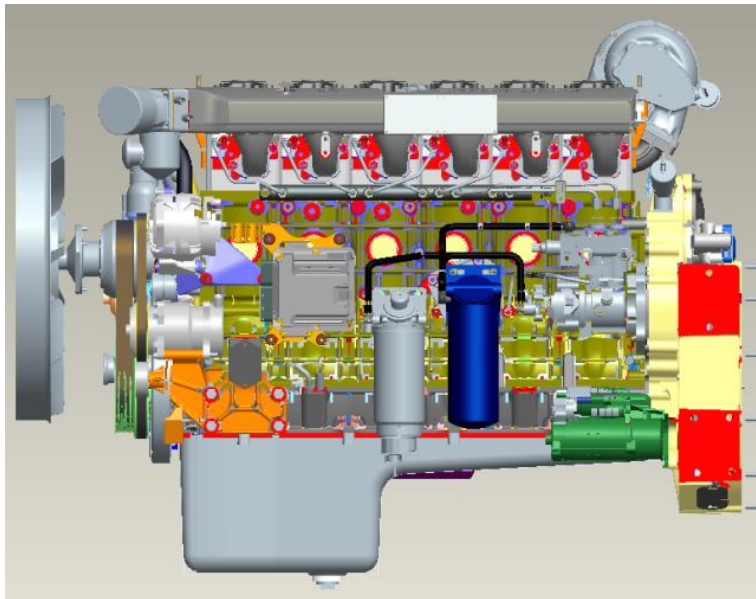

Figure 4-46 Layout of fuel system

4.6.1 Disassembly and assembly of fuel system

4.6.1.1 Exploded view of fuel system

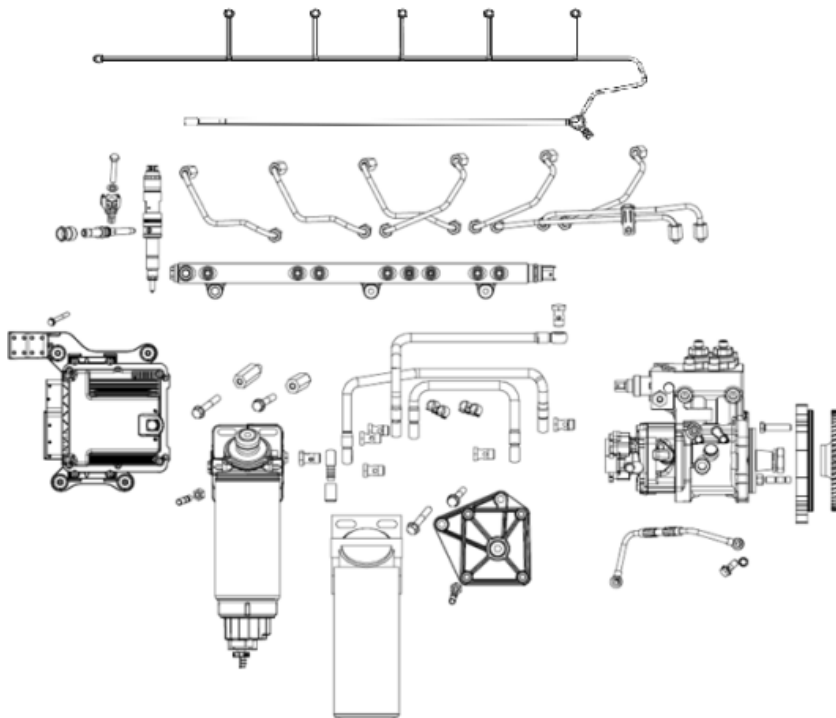

Figure 4-47 Exploded view of fuel system

4.6.1.2 Disassembly of fuel system

- 1) Disassemble the harness;

- 2) Disassemble the low pressure fuel pipe;
- 3) Disassemble the high pressure fuel pipe;
- 4) Disassemble the high pressure connector
- 5) Disassemble the fuel injector;
- 6) Disassemble the ECU;
- 7) Disassemble the filter;
- 8) Disassemble the high pressure fuel pump.

4.6.1.3 Assembly of fuel system

The assembly procedure is in reverse order to that of disassembly.

4.6.2 Disassembly and assembly of common rail pipe

4.6.2.1 Exploded view of common rail pipe

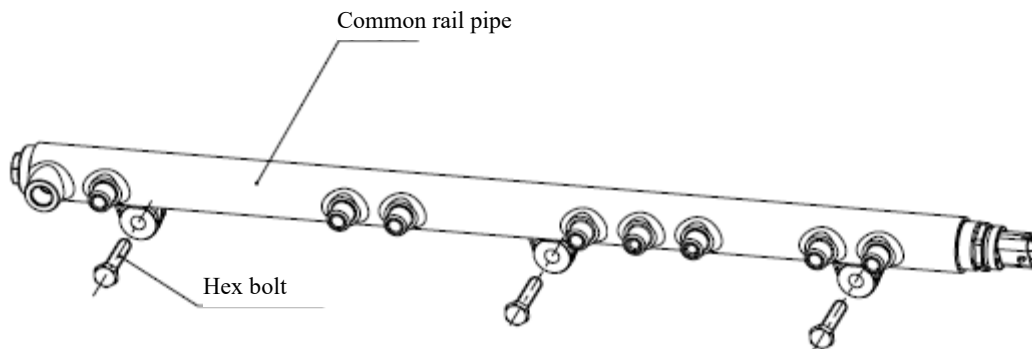

Figure 4-48 Exploded view of common rail pipe

4.6.2.2 Disassembly of common rail pipe

- 1) Disassemble the three fixing bolts for common rail pipe;
- 2) Disassemble the common rail pipe.

4.6.2.3 Assembly of common rail pipe

The assembly procedure is in reverse order to that of disassembly.

4.6.3 Disassembly and assembly of ECU

4.6.3.1 Exploded view of ECU

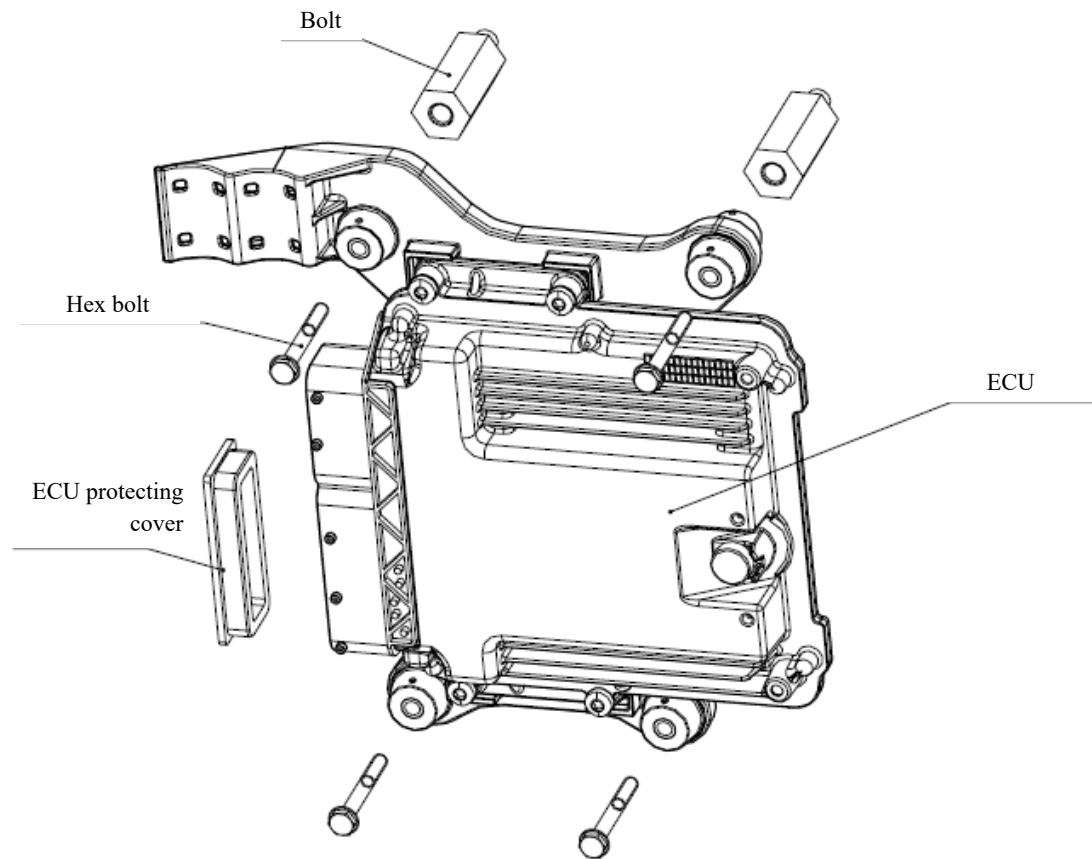

Figure 4-49 Exploded view of ECU

4.6.3.2 Disassembly of ECU

- 1) Disassemble the four fixing bolts for ECU;
- 2) Disassemble the ECU;
- 3) Disassemble the two set screws for supporting the ECU.

4.6.3.3 Inspection and maintenance of ECU

- 1) Check if the bolts and screws for fixing the ECU are reliably connected; and if they are loose, they shall be tightened with a wrench.
- 2) Check if the ECU pins are in good condition.

4.6.3.4 Assembly of ECU

The assembly procedure is in reverse order to that of disassembly.

4.6.4 Disassembly and assembly of fuel injection pump

4.6.4.1 Exploded view of fuel injection pump

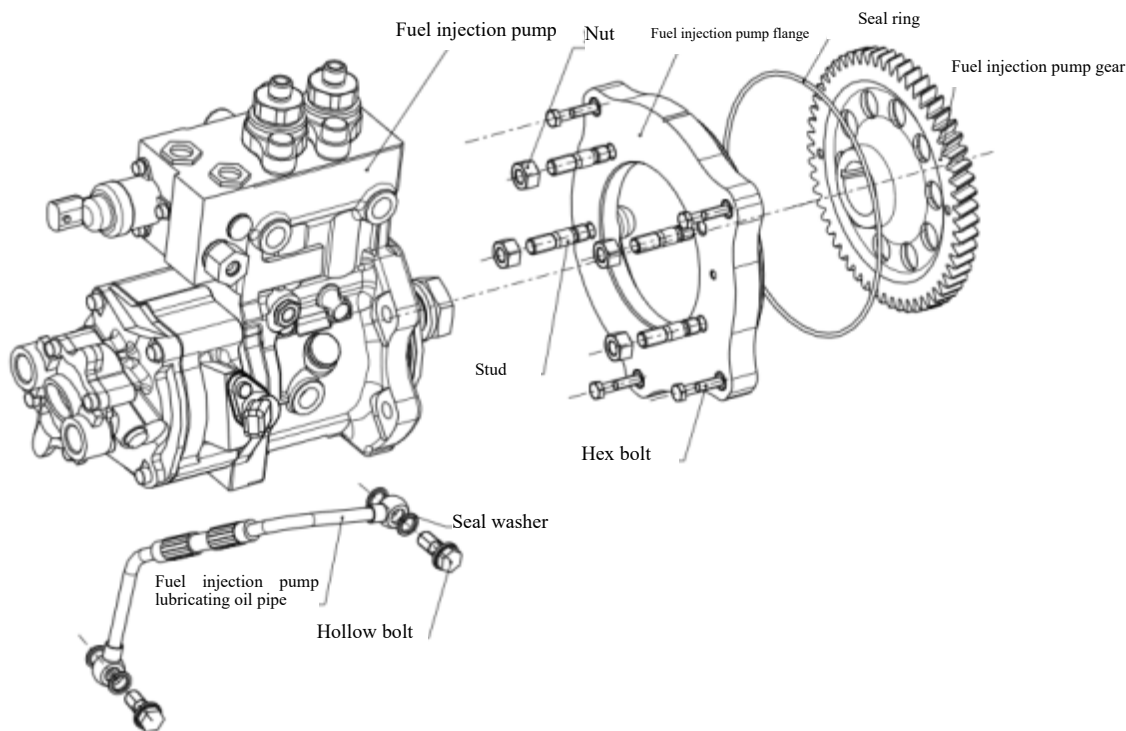

Figure 4-50 Exploded view of fuel injection pump

4.6.4.2 Disassembly of fuel injection pump

- 1) Disassemble the hex nuts between the fuel injection pump flange and gear case;
- 2) Disassemble the fuel injection pump and gear from the engine;
- 3) Disassemble the locknuts for fuel injection pump;
- 4) Disassemble the hex bolts between the fuel injection pump and the flange;
- 5) Disassemble the fuel injection pump flange.

4.6.4.3 Inspection and maintenance of fuel injection pump

See Figure 4-51 for structure of fuel injection pump. Rotate the flywheel and make the cylinder 1 of diesel engine to TDC of compression stroke, the scale marks on fuel injection pump gear and gearbox shall be aligned, as shown in Figure 4-52.

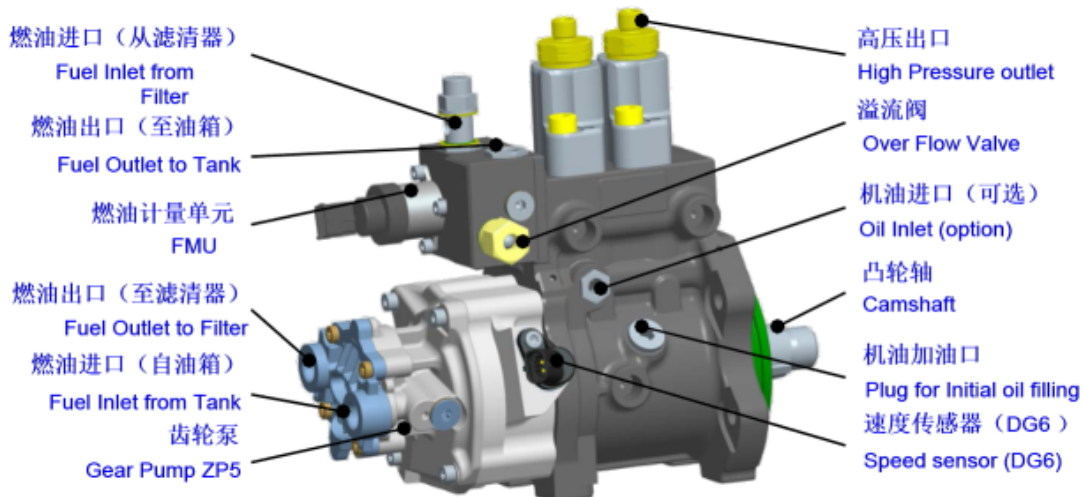

Figure 4-51 Structure diagram of fuel injection pump

4.6.4.4 Assembly of fuel injection pump

- 1) Install the fuel injection pump flange, and apply a small amount of lubricating oil onto the rubber ring of fuel injection pump.
- 2) Screw the hex bolts between the fuel injection pump and the flange.
- 3) Install the fuel injection pump gear, and the locknuts to fuel injection pump gear shall be M24×1.5, and shall be tightened to (250-300) Nm.
- 4) Rotate the flywheel and make the cylinder 1 of diesel engine to TDC of compression stroke; rotate the fuel injection pump gear until the scale mark on fuel injection pump gear aligns with the scale mark on fuel injection pump flange, and then install the fuel injection pump. Seeing through the inspection window at front end of gear case, the scale mark on fuel injection pump gear shall align with the scale mark on the gear case.
- 5) Install the hex nuts between the fuel injection pump and gear casing.

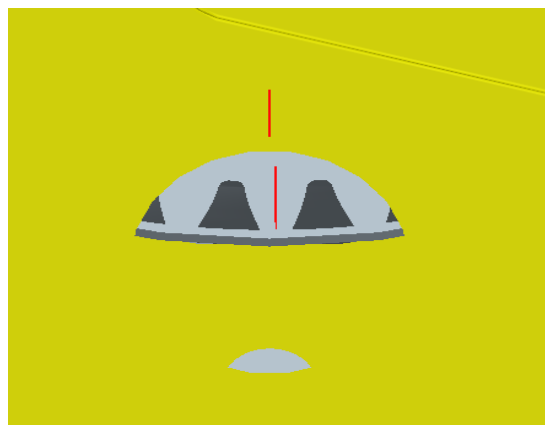

Figure 4-52 Fuel injection pump timing diagram

4.6.5 Disassembly and assembly high pressure fuel pipe

4.6.5.1 Exploded view of high pressure fuel pipe

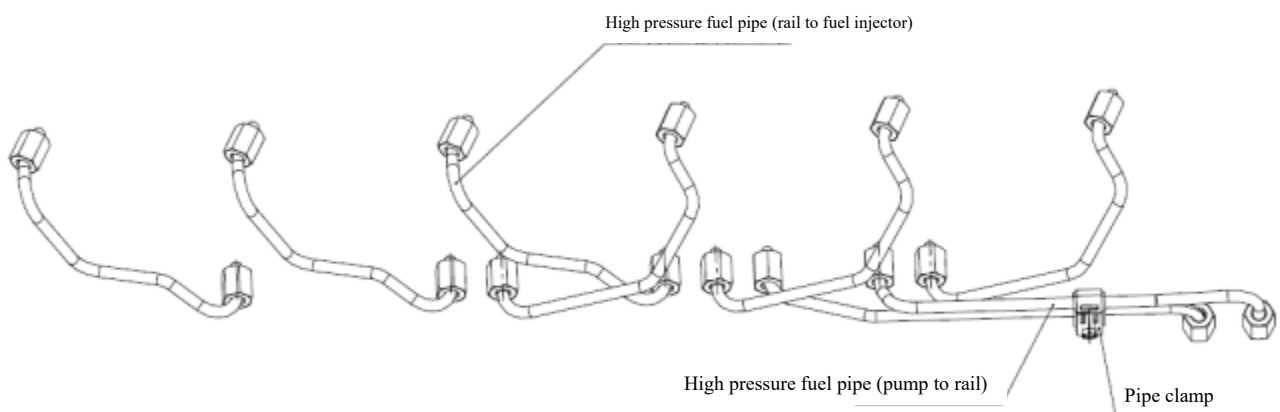

Figure 4-53 Exploded view of high pressure fuel pipe

4.6.5.2 Disassembly of high pressure fuel pipe

- 1) Disassemble the support for fixing the high pressure fuel pipe.
- 2) Disassemble the high pressure fuel pipe.

4.6.5.3 Inspection and maintenance of high pressure fuel pipe

- 1) Check if the high pressure fuel pipe connection nut is loose, and tighten it if necessary.
- 2) Check if there is air in high pressure fuel pipe: loosen the high pressure fuel pipe of a cylinder, and use a starter to drive the diesel engine to operate until fuel flows continuously out of the high pressure fuel pipe! (It is not recommended to disassemble the high pressure fuel pipe frequently.)

4.6.5.4 Assembly of high pressure fuel pipe

The assembly procedure is in reverse order to that of disassembly.

Note: The tightening torque of tight nuts for high pressure fuel pipe: at fuel injector end, (30-40) Nm; at rail end and oil pump end, (30-40) Nm.

4.6.6 Disassembly and assembly of fuel injector

4.6.6.1 Exploded view of fuel injector

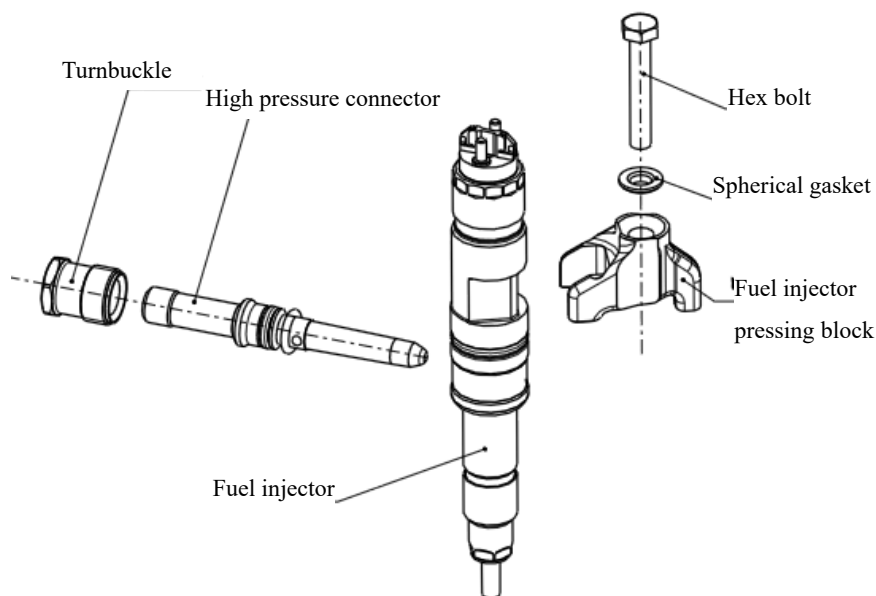

Figure 4-54 Exploded view of fuel injector installation pipe

4.6.6.2 Disassembly of fuel injector

- 1) Disassemble two hex bolts for fixing the fuel injector pressing block.
- 2) Disassemble the fuel injector pressing block and fixing block.
- 3) Take out the fuel injector assembly from the cylinder head.

4.6.6.3 Inspection and maintenance of fuel injector

The fuel injector nozzle can only be replaced at special Bosch service stations.

Marking of nameplate on oil injector:

Marking position: at electromagnetic valve on fuel injector top;

Note: Fuel injectors with different part numbers cannot be mixed in use, and fuel injectors of China III and Euro V cannot be mixed in use.



Figure 4-55 Fuel injector marking specification

4.6.6.4 Assembly of fuel injector

The assembly procedure is in reverse order to that of disassembly.

Note: The M8 fastening bolts to fuel injector (two bolts are of different lengths) shall be tightened symmetrically and their lateral clearance shall be consistent, i.e. (13-15) Nm.

4.6.7 Disassembly and assembly of fuel filter

4.6.7.1 Exploded view of fuel filter

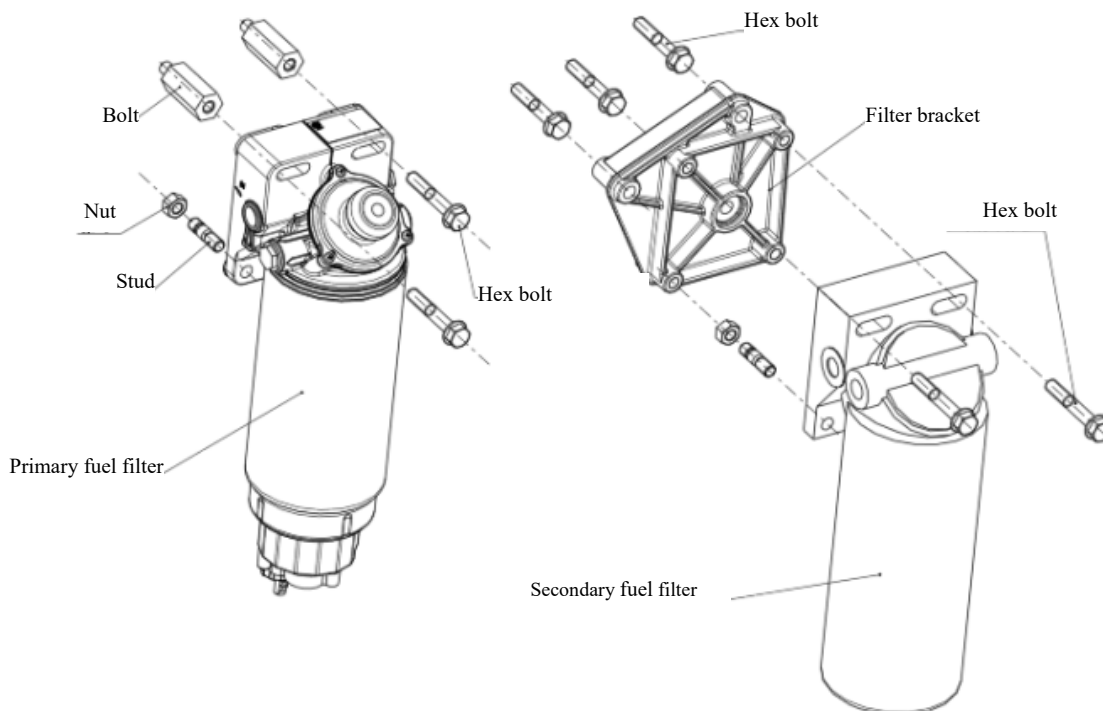

Figure 4-56 Exploded view of fuel filter

4.6.7.2 Disassembly of fuel filter

- 1) Disassemble the low pressure fuel pipe connected with the primary filter and secondary filter.
- 2) Disassemble the stud for fixing the primary filter.

- 3) Disassemble the hex bolt for fixing the primary filter.
- 4) Disassemble the screw for fixing the primary filter.
- 5) Disassemble the stud for fixing the secondary filter.
- 6) Disassemble the hex bolt for fixing the secondary filter.
- 7) Disassemble the hex bolt for fixing the filter bracket.

4.6.7.3 Inspection and maintenance of fuel filter

Irregularly check the water level in water cup of primary fuel filter, and drain water; replace the fuel filter element in around every 20,000 km.

4.6.7.4 Assembly

- 1) Disassemble the primary fuel filter element and secondary filter element with an appropriate wrench.
- 2) Clean the filter seat.
- 3) Apply oil onto the new filter element gasket.
- 4) Tighten by hand the filter element in place until the seal ring is in contact with the filter seat sealing surface.
- 5) Tighten with an appropriate wrench the filter element by 3/4-1 turn.
- 6) Unscrew the bleeder plug screw of the primary fuel filter, pump fuel with the hand pump on the primary fuel filter until fuel flows from the bleeder plug screw, and then tighten the bleeder plug screw.
- 7) Unscrew the hollow bolt at fuel outlet of secondary fuel filter, pump fuel with the hand pump on the fuel supply pump until fuel flows from the loosened hollow bolt, and then tighten the hollow bolt.

4.6.7.5 Assembly of fuel filter

The assembly procedure of fuel filter is in reverse order to that of disassembly.

4.6.8 Disassembly and assembly of low pressure fuel pipe

4.6.8.1 Exploded view of low pressure fuel pipe

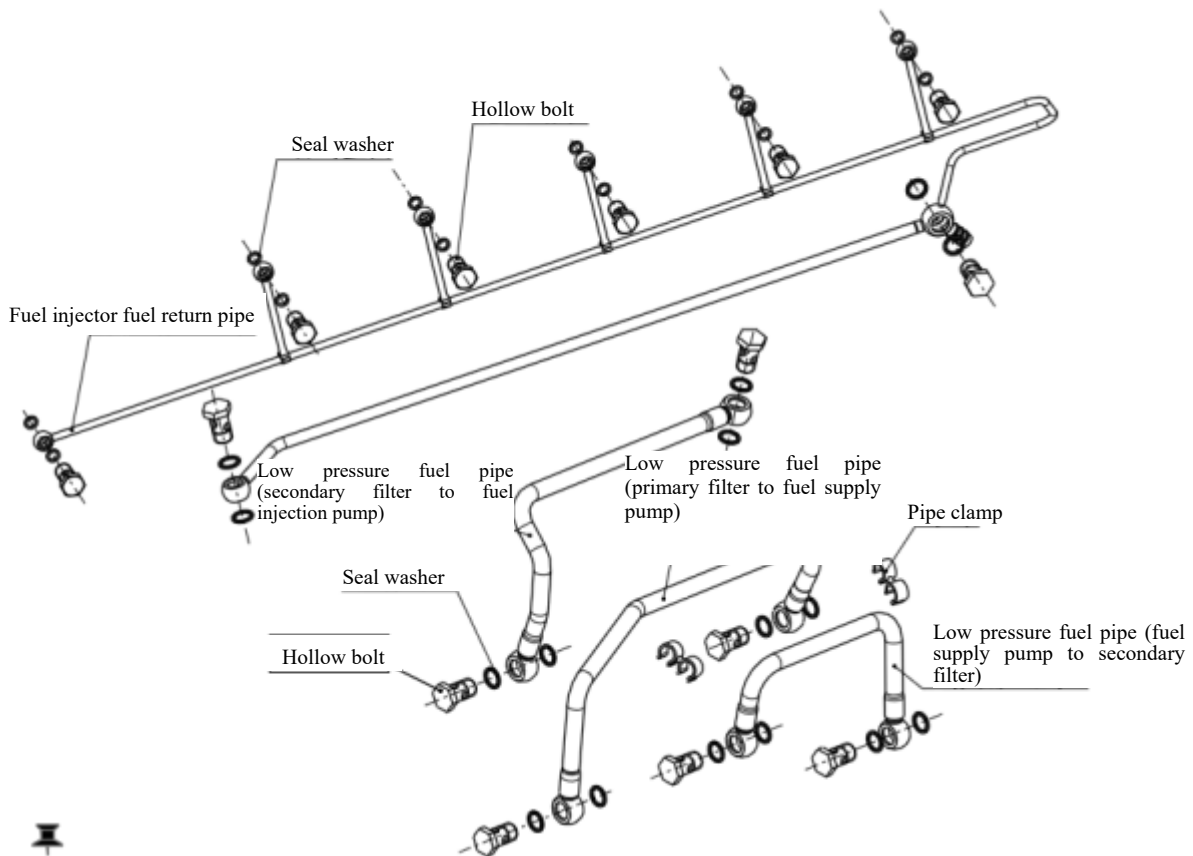

Figure 4-57 Exploded view of low pressure fuel pipe

4.6.8.2 Disassembly of low pressure fuel pipe

Disassemble the pipe clamp:

- 1) Disassemble the hollow bolt;
- 2) Disassemble the low pressure fuel pipe.

4.6.8.3 Inspection and maintenance of the low pressure fuel pipe

- 1) Be sure to prevent the low pressure fuel pipe from getting twisted and bent; pay special attention when using the rubber or plastic hoses.
- 2) The low pressure fuel pipe, connector and hydraulic component must be connected reliably to avoid leak.
- 3) The fuel pipe and connector shall not be made of metallic materials containing copper, zinc, lead or tin.
- 4) The fuel supply pipe and fuel return pipe shall be placed below the minimum fuel level in fuel tank, and the tank shall be provided with vent hole with filter screen.
- 5) Ensure certain clearance between the openings of fuel inlet and return pipes to prevent the bubbles brought by the return oil from being sucked into the inlet fuel pipe again, and at the same time to help lower the temperature of fuel sucked in.
- 6) The fuel return pipe shall be placed below the minimum fuel level in fuel tank to prevent air from entering along the fuel return pipe into the fuel pump after engine stop and cause difficulty in startup of engine.

7) The ventilation system of fuel tank shall be provided with appropriate air filter screen to prevent the dirt particles or other contaminants from entering into the fuel tank so as to reduce pollution of fuel, prolong the service life of filters, and reduce wear of the high pressure common rail system assembly. Check if there is air in the low pressure fuel passage and discharge the air therein.

8) Method of air removing: mainly to remove air in primary filter. Unscrew the bleed screw on the primary filter, operate the hand pump on the primary filter until fuel flows continuously out of the bleed screw.

4.6.8.4 Assembly of low pressure fuel pipe

The assembly procedure of low pressure fuel pipe is in reverse order to that of disassembly.

4.6.9 Disassembly and assembly of harness

4.6.9.1 Exploded view of harness

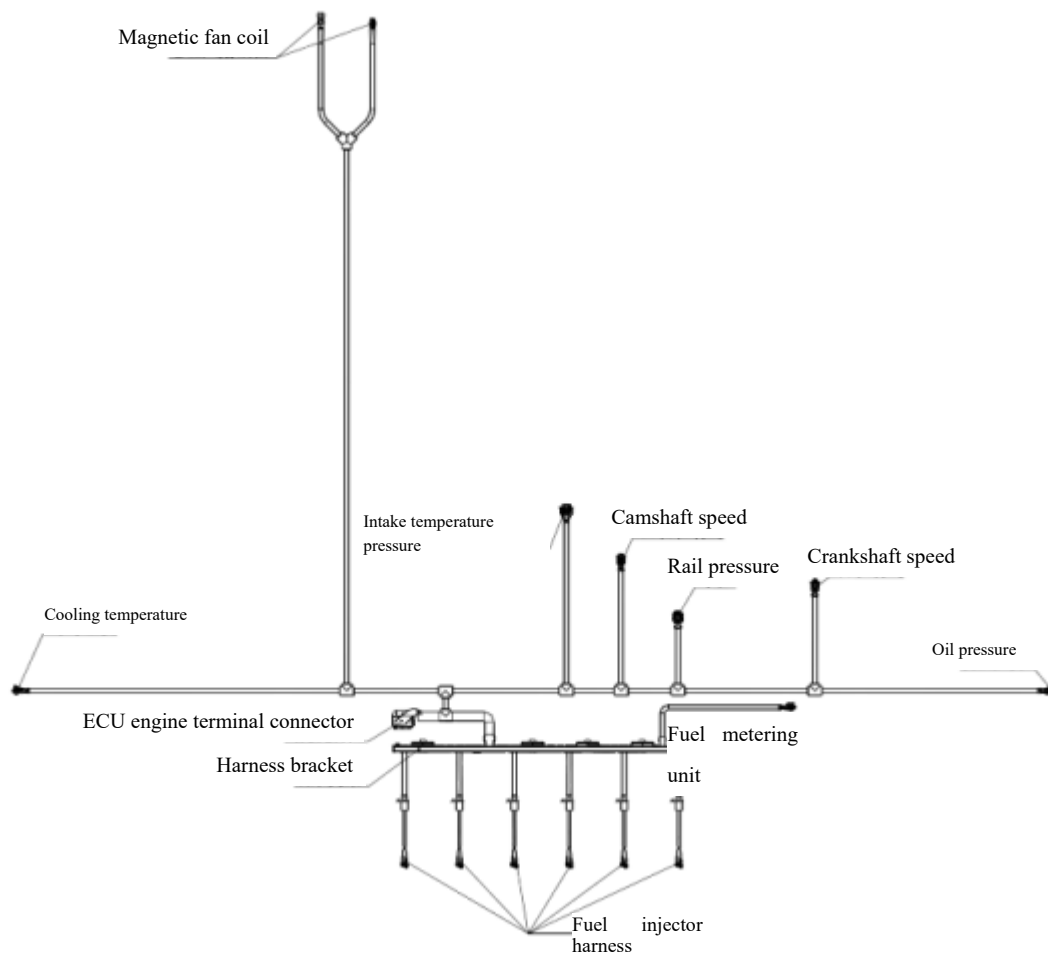

Figure 4-58 Engine harness diagram

4.6.9.2 Disassembly of harness

- 1) Disassemble the strap and support for fixing the harness.
- 2) Disassemble the harness connector and fuel injector harness terminal.
- 3) Disassemble the support for fixing the fuel injector harness.

4.6.9.3 Inspection and maintenance of harness

- 1) Make sure that at the harness connector, the harness is not over-bent, and the wire connection is not influenced by the greasy dirt, water, chips, mud and other impurities. If there are bare metal wire joints, the same shall be wrapped with insulating tape respectively to avoid short circuit.
- 2) The connection between the wire conductor and the joint shall not be directly sprayed with water.
- 3) For connection between the harness cable and the connector, there shall not be visible exposure of wire in the air and the insulating sheath shall be complete.

4.6.9.4 Assembly of harness

The assembly procedure of harness is in reverse order to that of disassembly.

4.7 Cooling system

4.7.1 Overview of cooling system

For WP12 series diesel engine, the water pump is installed at the front end of diesel engine, and the water inlet and outlet cavities of diesel engine are all designed at the exhaust side of cylinder block, with the water return cavity above the water inlet cavity. At the end of water outlet pipe, duplex thermostats are provided. The two thermostats are designed at inside of the water pump. The thermostat has two outlets, one leading to the water tank, and the other to the pump inlet, i.e. the short circulation. The WP12 diesel engine is provided with three thermostats that will open at different temperature (76°C, 83°C and 71°C). When the temperature of cooling water reaches the above values, the thermostats will open, and the cooling water is pumped into the engine block after being cooled through the radiator; but when the temperature of cooling water falls below these values, thermostats will cut off the afore-said passage, and the cooling water will directly enter into the inlet of water pump to allow the diesel engine to heat up as soon as possible to reach thermal state required for operation, and to avoid wear due to low temperature, so as to prolong the service life of diesel engine.

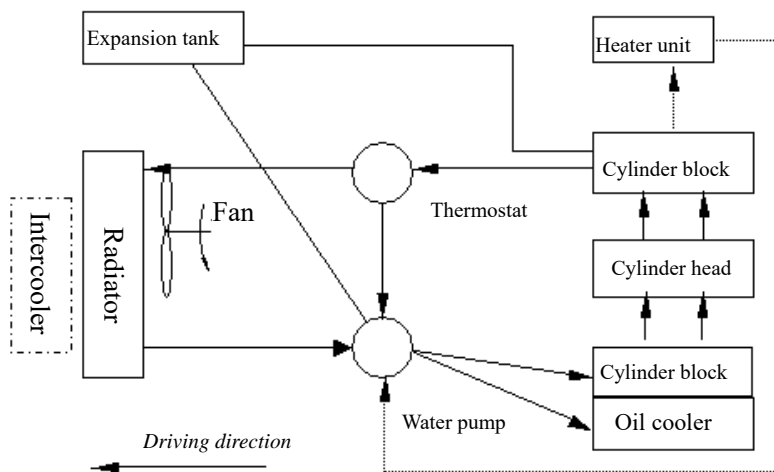

Figure 4-59 Cooling passage diagram of WP12 series diesel engine

4.7.1.1 Expansion tank

This part will be provided by the vehicle manufacturer. The detailed functions of the expansion tank include:

- ◆ To receive the coolant expanded when it is heated.
- ◆ To receive the coolant overflowing together with air from the vent line, and to separate air from the system.
- ◆ To store a certain amount of coolant to compensate for leak loss.

- ◆ To stabilize and limit the pressure of cooling system.
- ◆ Convenient for filling of coolant or inspection on liquid level.

All the cooling systems of WP12 series diesel engine must be provided with an independent or semi-independent expansion tank. The pressure in expansion tank shall be maintained at 50kPa, and the expansion tank shall be placed at least 400 mm above the diesel engine and radiator, at the peak of circulating water route of the entire cooling system. If necessary, when designing the expansion tank, partitions shall be provided inside the tank so as to prevent the cooling liquid from surging in case the vehicle is speeding up, slowing down or making a turn.

The capacity of expansion tank shall be no less than 15% of the total volume of coolant in the cooling system, while the air volume shall be approximately 7-12% of the total filling volume of the cooling system. That is, when filling the coolant for the first time, you can fill up to 60% of volume of expansion tank at most, and the rest 40% is left for expansion of coolant.

4.7.1.2 Exploded view of cooling system

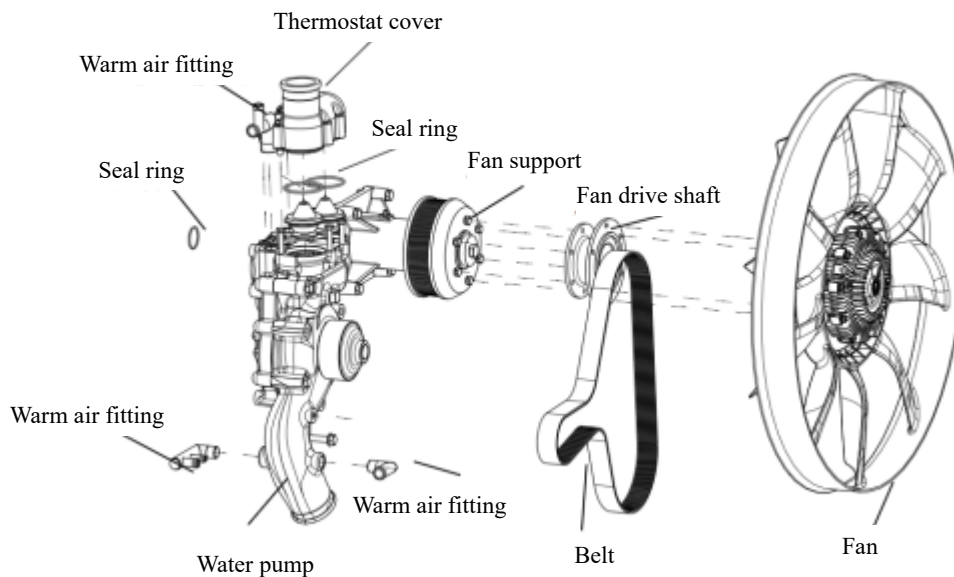

Figure 4-60 Exploded view of cooling system of WP12 series diesel engine

4.7.1.3 Disassembly of cooling system

- 1) Disassemble the fan and fan support;
- 2) Disassemble the belt and tensioner;
- 3) Disassemble the water pump;
- 4) Disassemble the thermostat.

4.7.2 Disassembly and assembly of water pump

4.7.2.1 Exploded view of water pump

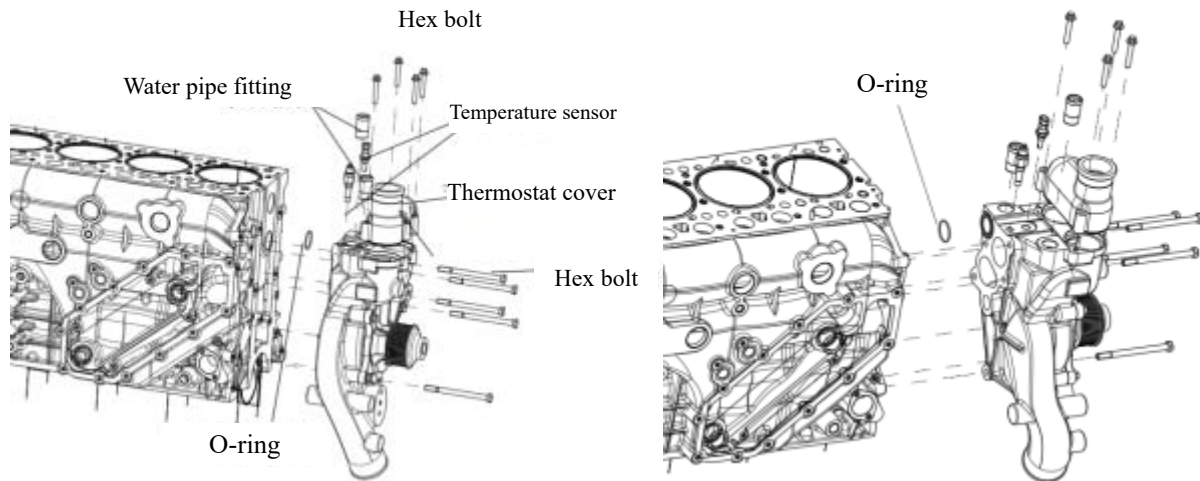

Figure 4-61 Exploded view of water pump

4.7.2.2 Disassembly of water pump

Unscrew the five bolts to disassemble the water pump, and then unscrew the bolts to disassemble the thermostat cover.

4.7.2.3 Inspection and maintenance of water pump

Check if the water pump rotates flexibly, check the seal ring for damages, and replace the affected if necessary.

4.7.2.4 Assembly of water pump

- 1) Grind the junction surface between the front end of cylinder block and back cover of water pump, clean them and then apply sealant on them. Apply Loctite 518 sealant onto the junction surfaces of the back cover of water pump and the cylinder block.
- 2) Insert appropriate O-ring into junction surface of back cover of water pump.
- 3) Install the water pump assembly and tighten it with bolts. Before installing, make sure to check if the pulley is rotating flexibly.

4.7.3 Disassembly and assembly of thermostat

4.7.3.1 Exploded view of thermostat

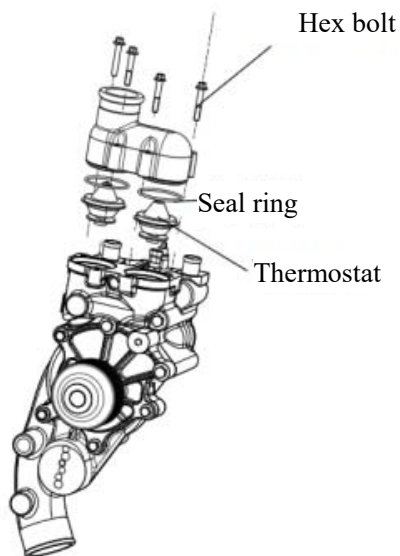

Figure 4-62 Exploded view of thermostat

4.7.3.2 Disassembly of thermostat

Disassemble the hex bolts to take out the thermostat.

4.7.3.3 Inspection and maintenance of thermostat

Check if the thermostat and seal ring are damaged, and replace them if necessary.

4.7.3.4 Assembly of thermostat

First unscrew the thermostat cover, put the thermostat into the water pump, and then add two O-rings and install the thermostat cover and tighten the bolts.

4.7.4 Disassembly and assembly of fan

4.7.4.1 Exploded view of fan

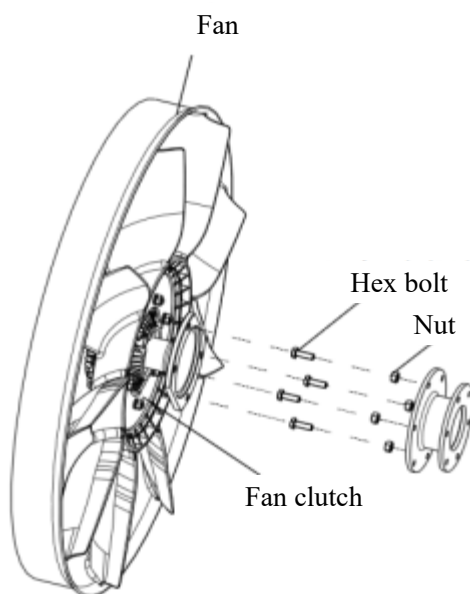

Fan drive shaft

Hex bolt

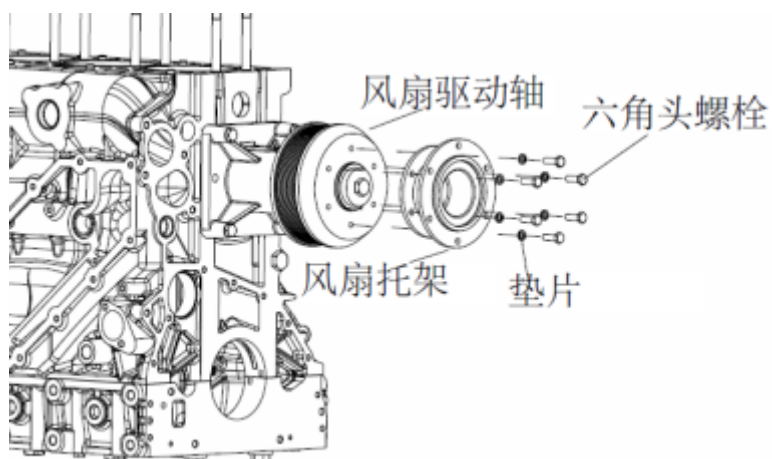

Figure 4-63 Exploded view of fan and fan drive shaft

4.7.4.2 Disassembly of fan

- 1) Disassemble four hex bolts for fixing the fan;
- 2) Disassemble six hex bolts for fixing the fan drive shaft.

4.7.4.3 Inspection and maintenance of fan

- 1) Check the fan blade for cracks and other damages, check if it rotates smoothly, and replace the fan if necessary.
- 2) Check the fan drive shaft for cracks. It is necessary to check the failure of drive shaft and replace the drive shaft if necessary.

4.7.4.4 Assembly of fan

- 1) Install the fan drive shaft with six hex bolts onto the fan support and tighten the bolts.
- 2) Install the fan with four bolts onto the fan drive shaft and tighten the bolts.

4.7.5 Disassembly and assembly of belt and tensioner

4.7.5.1 Exploded view of belt and tensioner

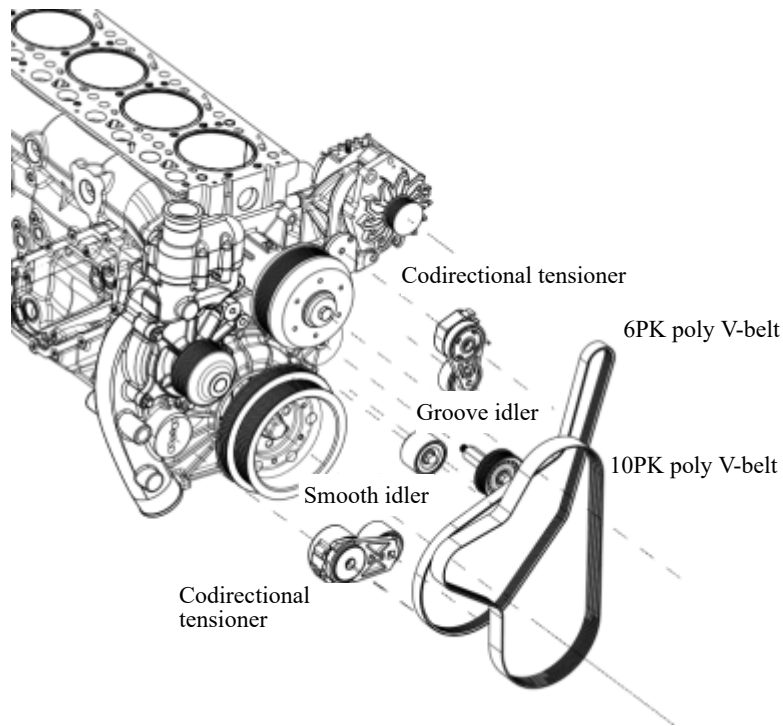

Figure 4-64 Exploded view of belt and tensioner

4.7.5.2 Disassembly of belt and tensioner

Rotate the codirectional tensioner anticlockwise with a wrench to take out the belt; unscrew the tensioner bolts and idler bolts with a wrench respectively, and remove the idler and tensioner.

4.7.5.3 Inspection and maintenance of belts and tensioner

Before disassembly, check the angle degree of tensioner to check if it is close to the limiting stopper. If it is rather close, then it is necessary to replace the belt, and check if the tensioner and idler are damaged, and replace them if necessary.

4.7.5.4 Assembly of belt and tensioner

- 1) Install the crank pulley onto the crankshaft.
- 2) Screw the crank pulley bolts and tighten them. First pre-tighten the bolts with tightening torque of 45Nm, and then rotate them by 135°.
- 3) Install the belt idler with bolts at left lower side of water pump and the front support of engine.
- 4) Install the belt tensioner at right lower side of water pump and alternator bracket.

Install the belt. After the belt is installed, pull out the pin for belt tensioner with pliers, then the belt will be tensioned automatically. When pulling out the pin for belt tensioner, make sure that the belt and the belt tensioner are aligned.

4.8 Lubricating system

4.8.1 Overview of lubricating system

The functions of lubricating system include reducing wear, flushing, cooling and rust protection. The oil shall be selected according to Weichai's corporate standards. Multi-grade oil is preferable as it is beneficial to cold start performance. The multi-grade oil used all year round like 15W40 can only be used under specified

temperature range. In case of occasional low temperature, you can take measures to preheat the oil or to use the oil that is fit for the ambient temperature.

Note: The WP12 series diesel engine shall not use lubricating oil of grades CE, CD, CC, CB and CA. Remember to replace the oil filter element whenever replacing the oil!

The WP12 series diesel engine mainly adopts pressure lubrication; the oil pump sucks in the oil from oil pan through the strainer, and then force the oil into the oil filter and oil cooler, and then reaching the position to be lubricated through oil piping system. The majority of oil reaches the main bearing and arrives at the connecting rod bearing through the oil holes in the crankshaft. The surface of cylinder liner and piston pin are lubricated with oil sprayed by the piston cooling nozzle. For the valve control system, turbocharger, common rail fuel pump, air compressor and intermediate gear bearing, pressure lubrication is adopted also. The piston top is cooled by the oil sprayed into the inner cooling cavity. The oil is cooled by cooling water through the oil cooler. The oil pressure in oil circulation system is regulated through the pressure-limiting valve in the oil pump body. The oil passage layout diagram of WP12 series diesel engine is shown in figure 4-65.

When starting the diesel engine, as the oil temperature is low and the oil viscosity is high, the oil pressure will be excessively high in a short time. However, as the diesel engine water temperature rises, the oil temperature will rise, and the oil pressure will gradually fall. When the water temperature of diesel engine at full load is 80-95°C, the normal oil pressure will be 350-550kPa.

4.8.1.1 Exploded view of lubricating system

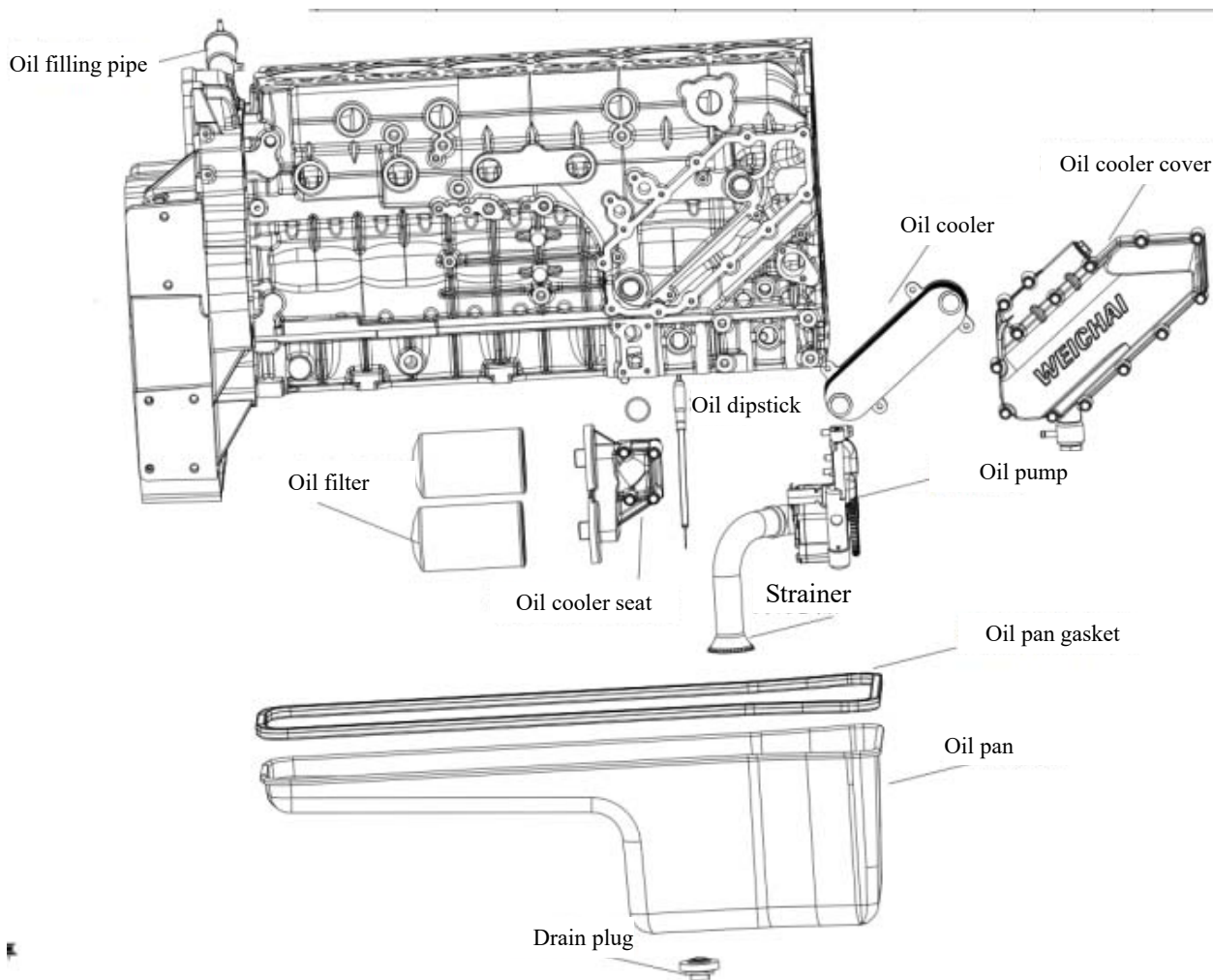

Figure 4-65 Oil passage layout diagram of WP12 series diesel engine

4.8.1.2 Disassembly of lubricating system

- 1) Disassemble the oil pan and oil dipstick and drain plug; please refer to the disassembly instructions for engine block assembly.
- 2) Disassemble the strainer.
- 3) Disassemble the oil pump.
- 4) Disassemble the oil cooler cover.
- 5) Disassemble the oil cooler.
- 6) Disassemble the oil filter.
- 7) Disassemble the oil filter seat.

4.8.1.3 Assembly of lubricating system

The assembly procedure is in reverse order to that of disassembly.

4.8.2 Disassembly and assembly of oil pump

4.8.2.1 Exploded view of oil pump

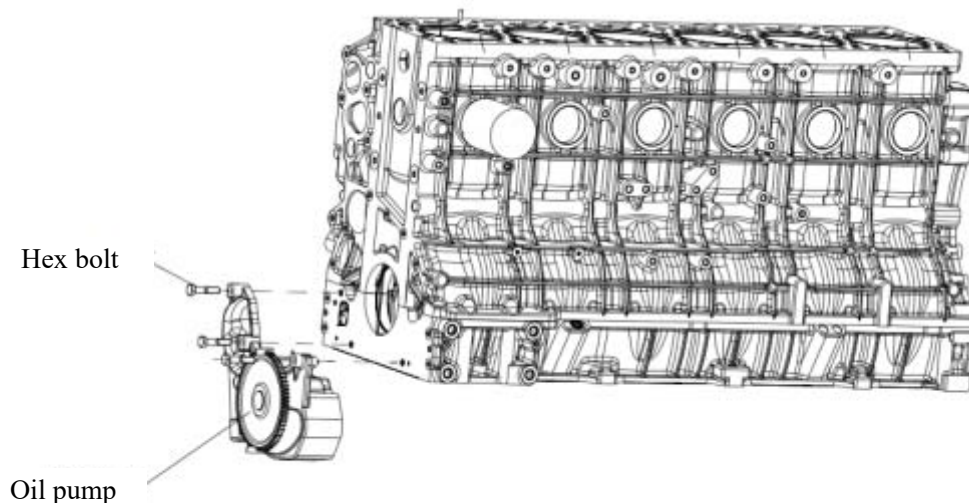

Figure 4-66 Exploded view of oil pump

4.8.2.2 Disassembly of oil pump

- 1) Unscrew the hex bolts;
- 2) Disassemble the oil pump.

4.8.2.3 Inspection and maintenance of oil pump

- 1) Check the oil pump for cracks and other damages; check if the oil pump drive gear can rotate freely.
- 2) Replace the oil pump if necessary.

4.8.2.4 Assembly of oil pump

- 1) Before assembling, first check the oil pump and hex bolts and make sure that they are free of manufacturing and use defects and damages.

- 2) Clean the junction surface between the crankcase and the oil pump.
- 3) Install the hex bolts and tighten them.

4.8.3 Disassembly and assembly of oil filter and oil filter seat

4.8.3.1 Exploded view of oil filter and oil filter seat

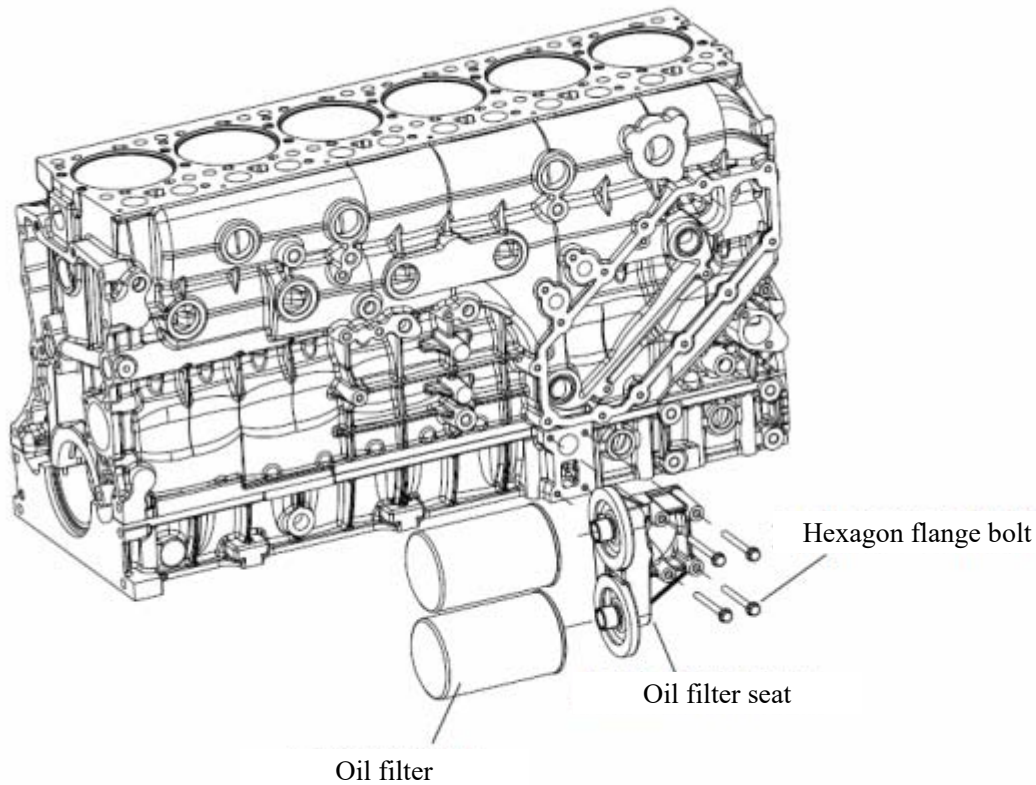

Figure 4-67 Exploded view of oil filter and oil filter seat

4.8.3.2 Disassembly of oil filter and oil filter seat

First, disassemble the oil filter with special tooling; unscrew the four bolts for fixing the oil filter seat, and then disassemble the oil filter seat.

4.8.3.3 Inspection and maintenance of oil filter and oil filter seat

- 1) Check the filter for impact damages and check the junction surface between the oil filter seat and oil filter for oil leakage; replace them if necessary.
- 2) Check the bolt and threads for deformation, and replace them if necessary.

4.8.3.4 Assembly of oil filter and oil filter seat

- 1) Polish the junction surface between the oil filter and the engine block, and clean the inner chamber of oil filter seat with compressed air.
- 2) Take out the spin-on oil filter element and install it on the oil filter seat.

4.8.4 Disassembly and assembly of oil cooler cover

4.8.4.1 Exploded view of oil cooler cover

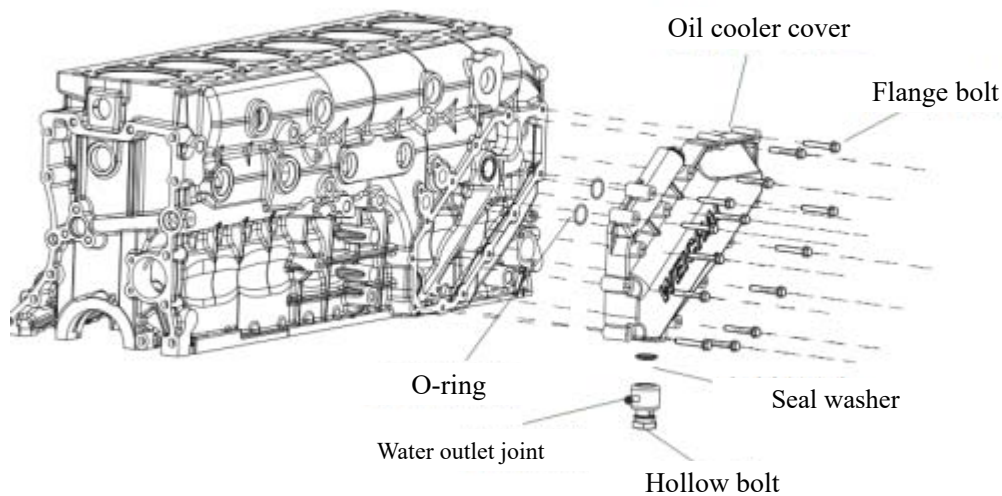

Figure 4-68 Exploded view of oil cooler cover

4.8.4.2 Disassembly procedure of oil cooler cover

Before disassembling, first drain off the coolant from the engine, and loosen the hollow bolts on the oil cooler cover in sequence, then remove the oil cooler cover and O-ring.

4.8.4.3 Inspection and maintenance of oil cooler cover

- 1) Check the oil cooler cover for cracks and other damages, and replace the oil cooler cover if necessary.
- 2) Check the seal ring of oil cooler cover for damages; if there is water leak, then check if the seal ring is failure, and replace the seal ring.

4.8.4.4 Assembly of oil cooler cover

- 1) Before installing the oil cooler cover, first check the oil cooler cover and the seal ring to make sure that there is no manufacture and use defects or damages.
- 2) Clean the junction surface between the oil cooler cover and the engine block, and install the oil cooler cover.
- 3) Screw the bolts to oil cooler cover and tighten them.
- 4) Install the water outlet joint, which shall be applied with seal washer at the two ends of the joint, and then tighten the hollow bolts.

4.8.5 Disassembly and assembly of oil cooler

4.8.5.1 Exploded view of oil cooler

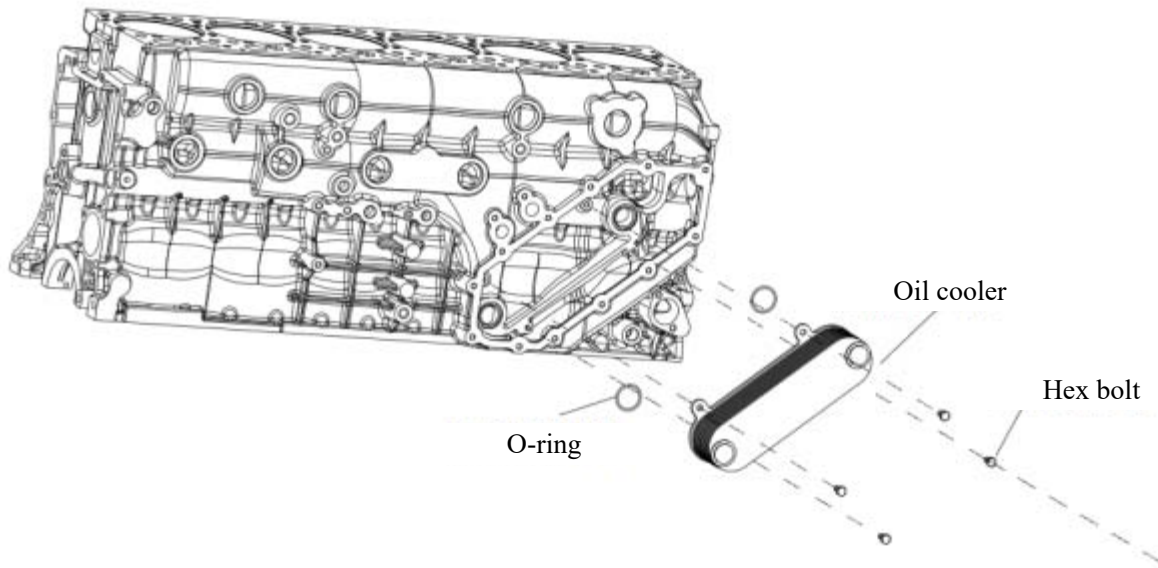

Figure 4-69 Exploded view of oil cooler

4.8.5.2 Disassembly of oil cooler

Before disassembly, first drain off the coolant from the engine, and loosen the oil cooler bolts in sequence, then remove the oil cooler and O-ring.

4.8.5.3 Inspection and maintenance of oil cooler

- 1) Check the oil cooler for cracks and other damages, and replace the oil cooler if necessary.
- 2) Check the seal ring of oil cooler for damages; if there is water leak, then check if the seal ring is failure, and replace the seal ring if necessary.

4.8.5.4 Assembly of oil cooler

- 1) Before installing the oil cooler, first check the oil cooler and the seal ring to make sure that there is no manufacture and use defects or damages.
- 2) Clean the junction surface between the oil cooler and the engine block, and install the oil cooler.
- 3) Screw the bolts to oil cooler and tighten them.

4.8.6 Disassembly and assembly of oil pump strainer

4.8.6.1 Exploded view of oil pump strainer

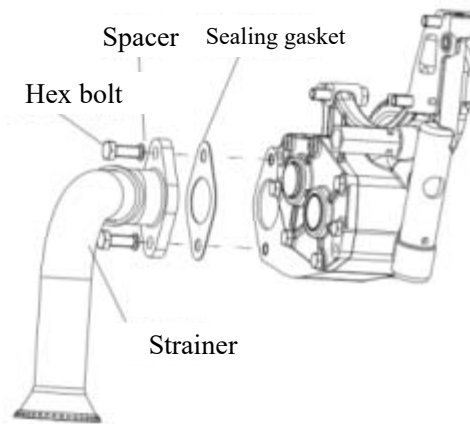

Figure 4-70 Exploded view of oil pump strainer

4.8.6.2 Disassembly of strainer

Unscrew the two hex bolts on the strainer, and remove the strainer and strainer gasket.

4.8.6.3 Inspection and maintenance of strainer

- 1) Check the strainer for cracks and other damages, check if the inner chamber of strainer is smooth, and replace the strainer if necessary.
- 2) Check the strainer gasket. If there is oil leak, it is necessary to check the strainer gasket for failure and replace the gasket.

4.8.6.4 Assembly of strainer

- 1) Before installing, first check the strainer and strainer gasket, and make sure that there is no manufacturing and use defect and damage.
- 2) Before installing, check the welding seams for cracks or solder skips, and install the strainer assembly.
- 3) Apply Weichai dedicated 242 sealant onto threads of strainer fastening bolts, then set a wave washer and install the hex bolts and tighten them.

4.9 Starting system

4.9.1 Disassembly and assembly of starting system

The starter of WP12 series diesel engine is of 5.4kW DC starter characterized by electromagnetic control, gear drive and torque transmission through friction plate starter drive. The starter circuit diagram is as shown in Figure 4-71.

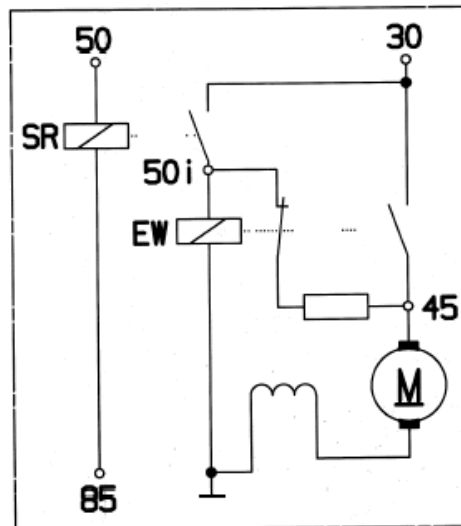

Figure 4-71 Starter circuit diagram

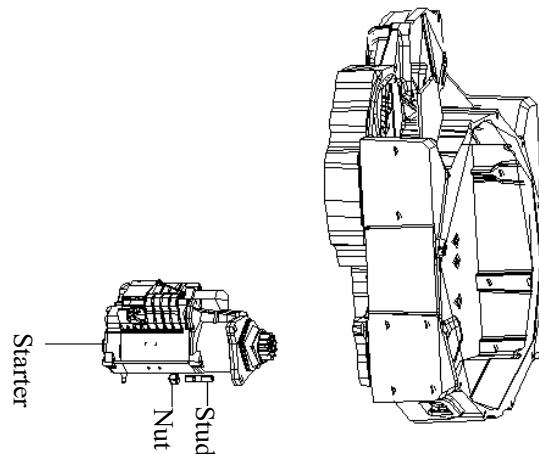

Figure 4-72 Exploded view of starter

4.9.2 Disassembly and assembly of starter

4.9.2.1 Disassembly of starter

Unscrew the two nuts with a general utility wrench and then remove the starter.

4.9.2.2 Inspection and maintenance of starter

- 1) Protect against splashing water, road mud and oil, and install the guard plate if necessary.
- 2) Protect against high-temperature to ensure that the temperature of starter casing is not higher than 100°C.
- 3) If the driver cannot monitor the starting process (e.g. commercial vehicle with engine installed in the rear end), to protect the starter and to prevent gear teeth collision, it is necessary to install the starting relay. The current capacity of starting relay shall be greater than 80A and the starter circuit should be cut off once the diesel engine begins to operate normally; the axis of starting relay shall be parallel to the ground, and vertical to moving direction of the vehicle so as to avoid accidental engagement of starter due to vibration, impact and other reasons.

4.9.2.3 Assembly of starter

Before installing, apply lithium grease for automobile onto starter gear, and then install the starter.

4.10 Accessories system of the vehicle

4.10.1 Disassembly and assembly of accessories system of vehicle

4.10.1.1 Exploded view of accessories system of vehicle

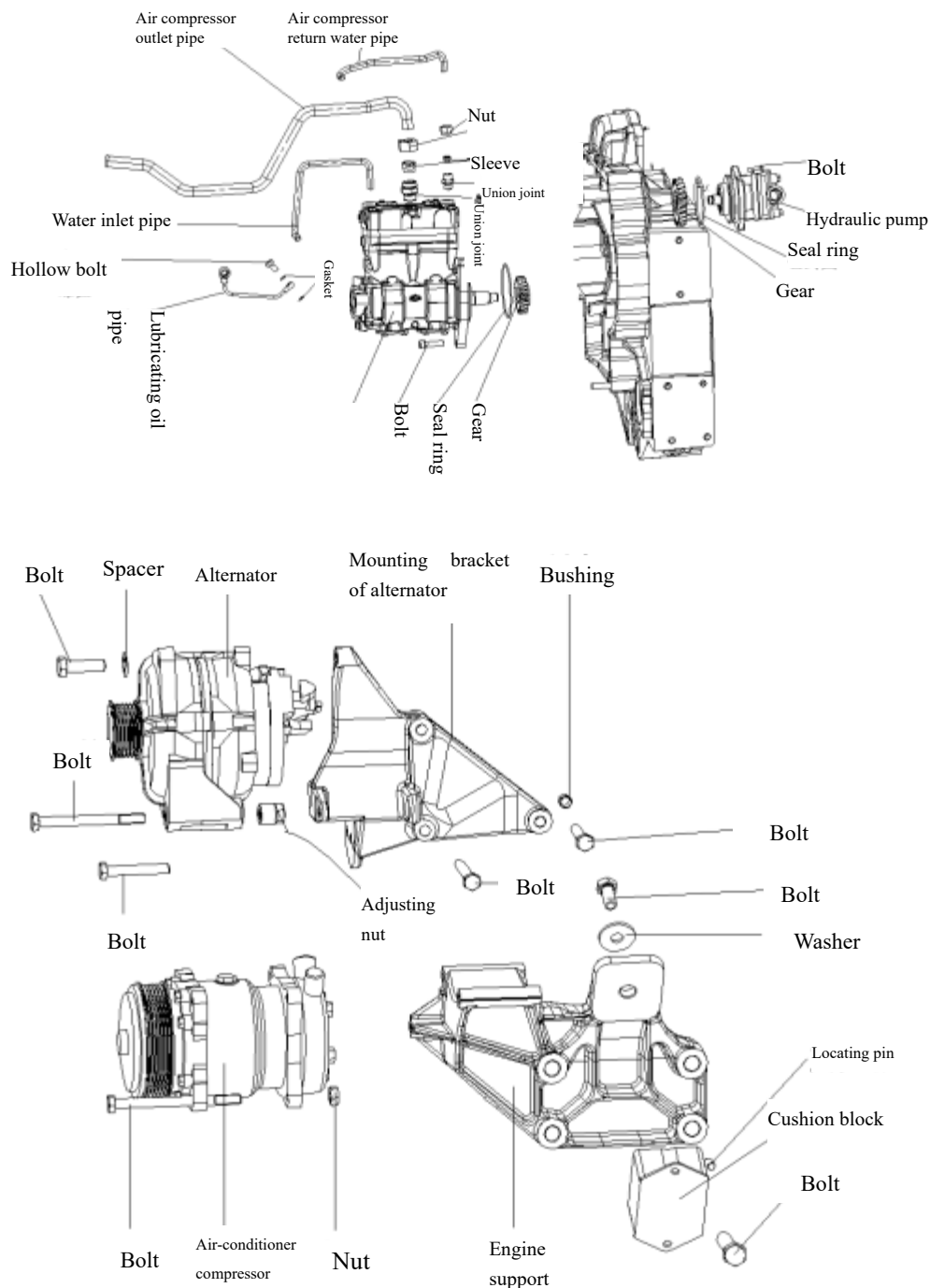

Figure 4-73 Accessories system of vehicle

4.10.1.2 Disassembly of accessories system of vehicle

- 1) Disassemble the alternator and mounting bracket of alternator.
- 2) Disassemble the air-conditioner compressor and engine support.

- 3) Disassemble the air compressor.
- 4) Disassemble the hydraulic pump.

4.10.1.3 Assembly of accessories system of vehicle

The assembly procedure is in reverse order to that of disassembly.

4.10.2 Disassembly and assembly of alternator

The rated voltage of alternator of WP12 series diesel engine is 28V, and the alternator is provided with transistor regulator. The alternator is connected in parallel with the battery in vehicle, and the alternator is self-excited when working. The alternator circuit diagram is as shown in Figure 4-74.

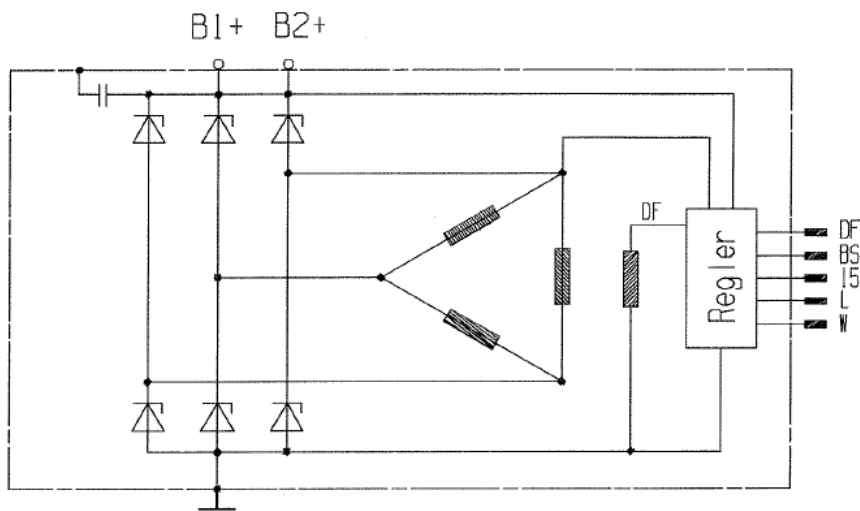

Figure 4-74 Circuit diagram of alternator

4.10.2.1 Exploded view of alternator assembly

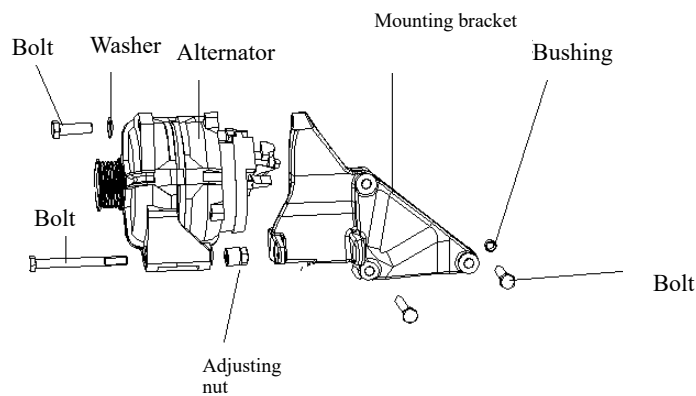

Figure 4-75 Exploded view of alternator and

4.10.2.2 Disassembly of alternator assembly

As shown in the above figure, first disassemble the two bolts of alternator to remove the alternator; disassemble the tree bolts for fixing the alternator mounting bracket and remove the alternator mounting bracket.

4.10.2.3 Inspection and maintenance of alternator assembly

- 1) Check if the alternator can rotate flexibly, and if there are cracks on the sleeve and bolts; replace them if necessary, and analyze the possible causes for such failures.
- 2) Check the alternator mounting bracket for cracks, and check the bushing for loosening, and check if the torque of bolts meets requirements.
- 3) Please note the followings during installation and wiring of alternator:
 - ◆ The alternator must be sufficiently cooled.
 - ◆ There must be protective measures against dust, splashing and oil.
 - ◆ Remember to check the tension of alternator belt.
 - ◆ The alternator can only be connected with the voltage regulator and battery.

4.10.2.4 Assembly of alternator assembly

- ① First install the locating bushing onto the engine block, and then install the alternator support onto the diesel engine with hex bolts.
- ② Fix the alternator onto the alternator bracket with two hex bolts and one hex nut.

4.10.3 Disassembly and assembly of air-conditioner compressor

4.10.3.1 Exploded view of air-conditioner compressor

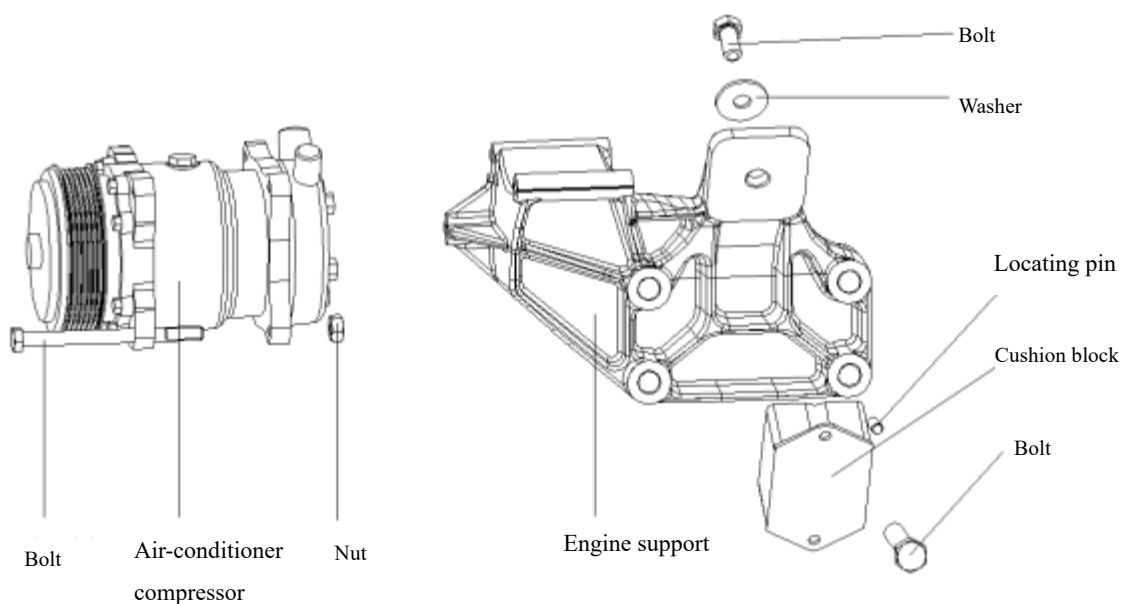

Figure 4-76 Exploded view of air-conditioner compressor and engine support

4.10.3.2 Disassembly of air-conditioner compressor assembly

- 1) Disassemble the bolts for fixing the air-conditioner compressor and remove the air-conditioner compressor.
- 2) Disassemble the four bolts connected with the engine block and then remove the engine support.

4.10.3.3 Inspection and maintenance of air-conditioner compressor assembly

Check the grooved pulley of air-conditioner compressor for foreign matter and wear, check if the engine support is damaged, and replace it if necessary.

4.10.3.4 Assembly of air-conditioner compressor assembly

- 1) Install the engine support onto the engine block.
- 2) Install the air-conditioner compressor onto the bracket and fix with hex bolts.

4.10.4 Disassembly and assembly of air compressor

4.10.4.1 Exploded view of air compressor

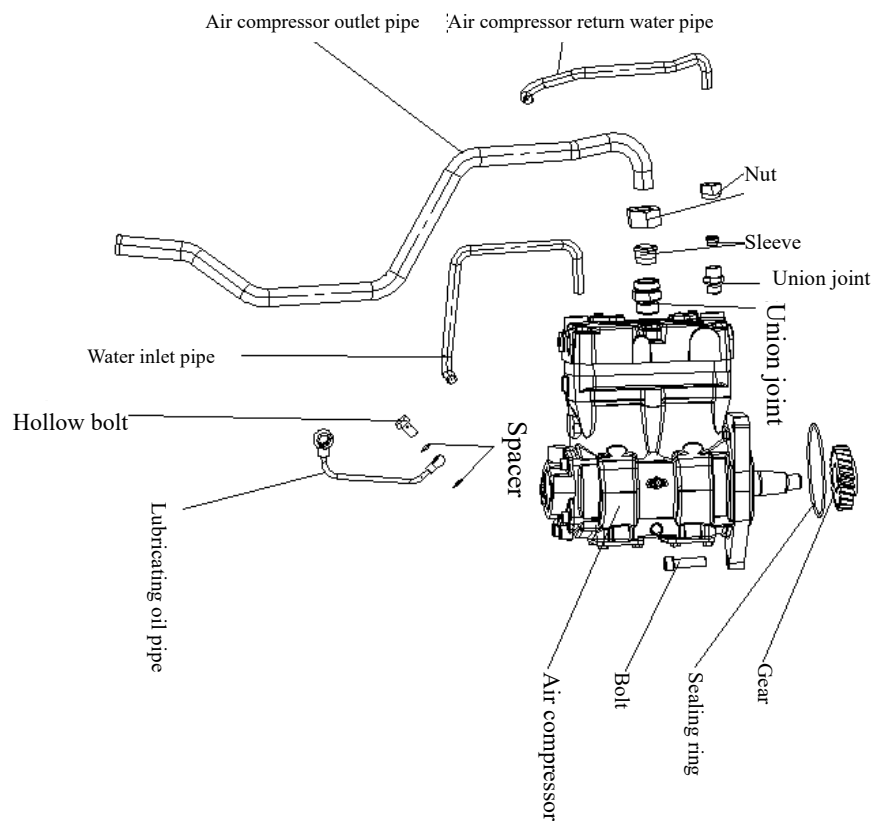

Figure 4-77 Exploded view of air compressor

4.10.4.2 Disassembly of air compressor

- 1) Disconnect air compressor outlet pipe and air bottle.
- 2) Disassemble the lubricating oil pipe of air compressor.
- 3) Disassemble the water inlet and outlet pipes of air compressor.
- 4) Disassemble the three bolts for fixing the air compressor, and remove the air compressor.

4.10.4.3 Inspection and maintenance of air compressor

- 1) Check the air compressor gear for damage, and replace it if necessary.
- 2) Check the seal ring and replace it if there is sign of aging.
- 3) Check the lubricating oil pipe for leakage, and replace it if necessary.

- 4) Check the water inlet and outlet pipes for leakage, and replace them if necessary.

4.10.4.4 Assembly of air compressor

- 1) Unscrew the air compressor nuts, install air compressor gear onto the drive shaft and fix it with air compressor nuts. The tightening torque of nut is (200 ± 50) Nm. Apply thread locker 242 to air compressor shaft threads.
- 2) Remove any sharp burrs and clean the junction surface between the air compressor and the gear case.
- 3) Install the O-ring onto air compressor flange face.
- 4) Install the pre-assembled air compressor assembly onto the flywheel housing connection plate. Install the air compressor bolts and tighten them.
- 5) Screw the double pipe joints onto the cylinder block and air compressor respectively and tighten them.
- 6) Clean the water inlet and outlet pipes of air compressor with compressed air, and then install the sleeve and union joint nuts onto both ends of water inlet and outlet pipes.
- 7) Install the water inlet and outlet pipes of air compressor, and then tighten the union joint nuts.
- 8) Clean the inlet and outlet pipes of air compressor air with compressed air, and then install the sleeve and union joint nuts onto the air compressor ends of air inlet and outlet pipes.
- 9) Install the inlet and outlet pipes of air compressor air, and then tighten the union joint nuts.
- 10) Connect the air compressor oil pipe onto the cylinder block and the air compressor with hollow bolt and seal washer, and tighten the hollow bolts.

4.10.5 Disassembly and assembly of hydraulic pump

4.10.5.1 Exploded view of hydraulic pump

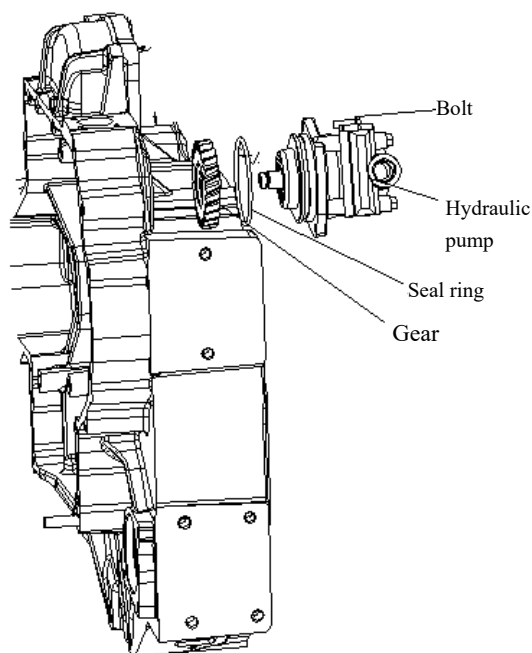

Figure 4-78 Exploded view of hydraulic pump

4.10.5.2 Disassembly of hydraulic pump

Unscrew the fixing bolts and remove the hydraulic pump.

4.10.5.3 Inspection and maintenance of hydraulic pump

Check the hydraulic pump gear for flexible operation, check the seal ring for damage, and replace the affected if necessary.

4.10.5.4 Assembly of hydraulic pump

Fit the O-ring into the hydraulic pump, and then install the hydraulic pump onto the flywheel housing with hex bolts.

Part V Tightening of Main Bolts of the Engine

5.1. Main bearing bolts

Apply lubricating oil to the thread and carrying surface of main bearing bolt (M18, a total of 14 bolts) before installation; the tightening shall be completed in six times in sequence as shown in the following figure.

First time: tighten with small torque pneumatic wrench;

Second time: tighten to 80Nm;

Third time: tighten to 140Nm;

Fourth time: turn by 70° in sequence;

Fifth time: turn by 70° in sequence again;

Sixth time: turn by 70° in sequence again.

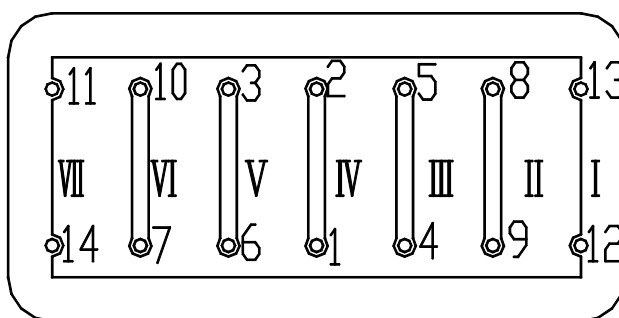

Figure 5-1 Tightening sequence of main bearing bolts

5.2. Cylinder head bolts

Tighten the secondary bolts numbered from 1 to 14 (M12×1.5, studs).

Tighten the main bolts numbered from 15 to 38 (M14×2).

Align the cylinder head in sequence, and apply lubricating oil to the threads and carrying surfaces of main bolts of secondary bolt nuts.

- ① Tighten the main bolts to a torque of (60 ± 6) Nm.
- ② Tighten the auxiliary bolts to a torque of (25 ± 3) Nm.
- ③ Tighten the auxiliary bolts by an angle of $120^\circ\pm 5^\circ$. Mark the location of the bolts with a color point.
- ④ Tighten the main bolts by an angle of $120^\circ\pm 5^\circ$. Mark the location of the bolts with a color point.
- ⑤ Tighten the auxiliary bolts by an angle of $120^\circ\pm 5^\circ$ again. Mark the location of the bolts with a color point.
- ⑥ Tighten the main bolts by an angle of $120^\circ\pm 5^\circ$ again. Mark the location of the bolts with a color point.

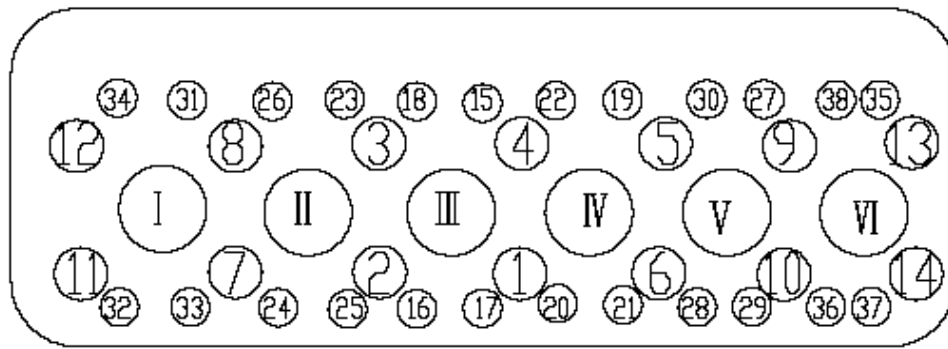

Figure 5-2 Tightening sequence of cylinder head bolts

5.3. Connecting rod bolts

Tightening manually: first tighten the bolts slightly, and then tighten them diagonally to a torque of 115Nm, and then rotate by $90^{\circ} \pm 5^{\circ}$ respectively.

Tightening with automatic wrench: first tighten the bolts slightly, and then tighten them diagonally to a torque of 80 Nm, and then rotate by $153^{\circ} \pm 5^{\circ}$ respectively.

Note: The connecting rod bolts cannot be reused.

After the connecting rod bolts are tightened in place, seal them with paint marker according to process.

5.4 Flywheel bolts

Tightening manually: After lubricating the threads and carrying surfaces of flywheel bolts, install the bolts into the threaded holes and tighten them diagonally to a torque of 105_0^{+20} Nm, and then rotate by $270^{\circ} \pm 5^{\circ}$.

Replace any flywheel bolt which cannot meet the torque requirements after rotating by the specified angle. The bolts can be used twice.

5.5 Tightening torques and methods of other bolts and nuts

Table 5-1 Tightening specifications for high load bolts

Bolt name	Bolt size	Tightening specifications	Bolt length, mm	Permissible use times (first time installation included)
Main bearing bolt	M18-10.9	140Nm+210°	169	4 (length of extended bolt should be less than 172mm)
Crankcase secondary bolt	DIN 912; M8-8.8	(20~25) Nm	25; 110	2
Main bolt of cylinder head	M14-10.9	60Nm+2×120°	185	3
Secondary bolt of cylinder head	M12×1.5-8.8	(20+10)Nm, Weichai special 262 sealant should	195, at least 175mm	3

		be used	protruding from the cylinder block	
Secondary bolt of cylinder head		25Nm+2×120°		3
Crankshaft pulley bolt	M12×1.5-10.9	45Nm+135°	75	2
Vibration damper bolt	DIN 933; M10-10.9	(60~70) Nm	30	2
Flywheel bolt	M16×1.5-10.9	105Nm+270°	120	2
Connecting rod bolt	M14×1.5	Tightening manually: 115Nm+90°	67.5	
		Tightening automatically: 80Nm+153°		
Tightening bolt for air compressor	DIN 912; M10-8.8	40Nm	1×30, for plate 2×40, for flywheel housing	
Fixing nut for air compressor gear (cylinder 1 and cylinder 2)	M20×1.5	(200+50)Nm		2
Idler gear bolt	DIN 931; M12×1.5-10.9	105Nm	90	
Fixing nut for common rail pump gear	M24	(250+50) Nm		2
Clamping bolt for injector	DIN 933; M8-8.8	8Nm+90°	50	3
Camshaft gear bolt	DIN 933; M8-10.9	8Nm+120°	30	2
Piston cooling nozzle bolt	DIN6921; M14×1.5-8.8	30Nm	25	
Exhaust manifold bolt	M10	(60~70) Nm	65	2
Water pump bolt (connecting water pump housing and intermediate housing)	DIN 931; M10-8.8	(40~46) Nm	4×80	

Table 5-2 Standard bolts

Friction coefficient.	0.125 (galvanized)				0.14 (shiny)			
Strength grade	6.9	8.8	10.9	12.9	6.9	8.8	10.9	12.9
Bolt size	Torque recommended (Nm)							
M4	2.3	2.7	3.8	4.6	2.4	2.9	4.1	4.9

M5	4.7	5.5	8.0	9.5	5.0	6.0	8.5	10
M6	8.0	9.5	13.0	16.0	8.5	10	14.0	17
M8	19	23	32	39	21	25	35	41
M10	39	46	64	77	41	49	69	83
M12	67	80	110	135	72	86	120	145
M14	105	125	180	215	115	135	190	230
M16	165	195	275	330	180	210	295	355
M18	225	270	390	455	245	290	405	485
M20	325	385	540	650	345	410	580	690
M22	435	510	720	870	465	550	780	930
M24	560	660	930	1100	600	710	1000	1200
M27	830	980	1400	1650	890	1050	1500	1800
M30	1100	1350	1850	2250	1200	1450	2000	2400

Notes:

- ① The angle value above listed is the further rotated angle after the bolts have been tightened to specified torque.
- ② The strength classes of the bolts and nuts used at various positions of the engine are different, and therefore, bolts and nuts with same specification and different strength class shall not be mixed in use. It is prohibited to reuse the bolts exceeding the specified number of times, or otherwise severe consequences will be caused.

Appendix A: Diagnostic Trouble Code Table

Description	Flash codes	P-Code	Components Related	Problem caused	Error Reasons	Solutions
Short-circuit to ground of fuel injection capacitor 1	151	P062D	Fuel injector 1, 2 and 3	Fuel injector 1, 2 and 3 do not work, affecting the performance of engine	Short-circuit to ground of fuel injector wiring harness	Inspect the wiring harness of fuel injector of cylinder 1, 2 and 3; and unplug the connector of the wiring harness of fuel injector to respectively measure the resistance to ground of the pin, if the value of resistance is more than 1MΩ, that means the wiring harness is normal
Short-circuit to ground of the fuel injection capacitor 2	151	P062E	Fuel injector 4, 5 and 6	Fuel injector 4, 5 and 6 do not work, affecting the performance of engine	Short-circuit to earth of fuel injector wiring harness	Inspect the wiring harness of fuel injector of cylinder 4, 5 and 6; and unplug the connector of the wiring harness of fuel injector to respectively measure the resistance to ground of the pin, if the value of resistance is more than 1MΩ, that means the wiring harness is normal
Test error of short-circuit to ground of fuel injection capacitor 1	426	P1581	Fuel injector 1, 2 and 3	Fuel injector 1, 2 and 3 do not work, affecting the performance of engine	Short-circuit to earth of fuel injector wiring harness	Inspect the wiring harness of fuel injector of cylinder 1, 2 and 3; and unplug the connector of the wiring harness of fuel injector to respectively measure the resistance to ground of the pin, if the value of resistance is more than 1MΩ, that means the wiring harness is normal
The test of short-circuit to ground of the fuel injection capacitance 2 is wrong	426	P1582	The fuel injector 4, 5 and 6	The fuel injectors 4, 5 and 6 cannot work, which will affect the performance of the engine	Short-circuiting to earth of the wiring harness of the fuel injector	Inspect the wiring harness of fuel injector of cylinder 4, 5 and 6; and unplug the connector of the wiring harness of fuel injector to respectively measure the resistance to ground of the pin, if the value of resistance is more than 1MΩ, that means the wiring harness is normal
PRV valve open error (it should be opened, but actually it hasn't)	136	P0088	High/low pressure fuel line and relevant components	The power of the engine is limited	Fault of the high/low pressure fuel line and relevant components	1. Check if the pressure relief valve is damaged
The high-pressure fuel pump is always operated under the maximum fuel delivery	136	P0088	High/low pressure fuel line and relevant components	The power of the engine is limited	Fault of the high/low pressure fuel line and relevant components	<ol style="list-style-type: none"> 1. Check the high/low pressure fuel line 2. Check flow measuring unit 3. Check fuel injector 4. Check the rail pressure sensor

Description	Flash codes	P-Code	Components Related	Problem caused	Error Reasons	Solutions
When the inlet air heating grid is off, the voltage signal is high	323	P2609	Inlet air heating grid	Inlet air heating is malfunction	1. Inlet air heating grid is malfunction; 2. The drive circuit of inlet air heating grid is malfunction	1. Check if the resistance value of the inlet air heating grid is about 0.4Ω; 2. Check the related wiring harness of the drive circuit of inlet air heating grid
When the inlet air heating grid is off, the voltage signal is low	323	P2609	Inlet air heating grid	Inlet air heating is malfunction	1. Inlet air heating grid is malfunction; 2. The drive circuit of inlet air heating grid is malfunction	1. Check if the resistance value of the inlet air heating grid is about 0.4Ω; 2. Check the related wiring harness of the drive circuit of inlet air heating grid
When the inlet air heating grid is on, the voltage signal is higher	323	P2609	Inlet air heating grid	Inlet air heating is malfunction	1. Inlet air heating grid is malfunction; 2. The drive circuit of inlet air heating grid is malfunction	1. Check if the resistance value of the inlet air heating grid is about 0.4Ω; 2. Check the related wiring harness of the drive circuit of inlet air heating grid
When the inlet air heating grid is on, the voltage signal is lower	323	P2609	Inlet air heating grid	Inlet air heating is malfunction	1. Inlet air heating grid is malfunction; 2. The drive circuit of inlet air heating grid is malfunction	1. Check if the resistance value of the inlet air heating grid is about 0.4Ω; 2. Check the related wiring harness of the drive circuit of inlet air heating grid
The inlet air heating grid is always on	322	P2609	Inlet air heating grid Control relay	The inlet air heating do not work/the wiring harness is burnt-out	1. The inlet air heating flange is not connected. 2. The circuit of the inlet air heating flange is shorted	1. Connect the inlet air heating flange 2. Check if the heating flange is open circuit of or short circuit



Description	Flash codes	P-Code	Components Related	Problem caused	Error Reasons	Solutions
The cold start temperature _0 is untrusted	481	P1000	Water temperature sensor	Cold starting cannot work	Fault of the water temperature sensor	1. Check the wiring harness and socket connector of the water temperature sensor (check the open-short state of the connector to A28 and A29; and check if the voltage to earth of A28 is 5V); 2. Replace the water temperature sensor; and the normal resistance value of the water temperature sensor is about few KΩ
The cold start temperature _1 is untrusted	481	P1001	Upstream temperature sensor	The cold starting cannot work	Fault of the upstream temperature sensor	1. Check the wiring harness and socket connector of the upstream exhaust temperature sensor (check the open-short state of the connector to K81 and K82; and check if the voltage to earth of K81 is 5V); 2. Replace the upstream exhaust temperature sensor (the normal resistance value of the exhaust temperature sensor is about several hundred Ω)
The cold start temperature _2 is untrusted	481	P1002	Inlet air temperature sensor	The cold starting cannot work	Fault of the inlet air temperature sensor	1. Check the inlet air temperature sensor and socket connector (check the open-short state of the connector to A27, A42, A09 and A43; and check if the voltage to earth of A09 and A27 is 5V); 2. Replace the inlet air temperature sensor (the resistance value of 1 and 2 pins is about 2KΩ)
Many temperature values during the cold starting are untrusted	481	P1005	Water temperature, upstream exhaust temperature and inlet air temperature sensors	The cold starting cannot work	Fault of water temperature, upstream exhaust temperature and inlet air temperature sensors	1. Check the inlet air temperature, upstream exhaust temperature, water temperature sensors and socket connector; 2. Replace the inlet air temperature, water temperature and upstream exhaust temperature sensors

Description	Flash codes	P-Code	Components Related	Problem caused	Error Reasons	Solutions
Actuator_0 is shorted to power supply	114	P0659	Inlet air heating and indicating lights; start relay or exhaust brake solenoid valve	Relevant indicating light or solenoid valve cannot work	K68, K29 and A45 are the output power supply of ECU, which cannot be connected to the constant power of the whole vehicle	Check if the voltage of K68, K29 and A45 is 24V when the key is turned off. If any, change the vehicle circuit
Actuator_1 is shorted to power supply	115	P2671	The solenoid valve and lamp connected to the whole vehicle; after treatment part is not considered	The relevant components cannot work	K94, K92, K50, K25, K26 and the whole vehicle voltage input	Check if the open-circuit voltage of K94, K92, K50, K25 and K26 is 3.5V; if not, check if it is shorted with other circuit
Actuator_2 is shorted to power supply	116	P2686	Wiring harness of the urea dosing pump	Urea pressure cannot be set by the urea dosing pump	There is voltage input of the whole vehicle for K93	Unplug the connector of urea dosing pump to measure if the voltage of K93 at the ECU end is within 0-25mV; if not, check if K93 is shorted with other circuit
Actuator_0 is shorted to ground	114	P0658	Inlet air heating and indicating light; start relay or exhaust brake solenoid valve	The relevant indicating light or solenoid valve cannot work	K68, K29 and A45 are the output power supply of ECU, which cannot be connected to the constant power of the whole vehicle	Check if the voltage of K68, K29 and A45 is 24V when the key is turned off. If any, change the circuit of the whole vehicle

Description	Flash codes	P-Code	Components Related	Problem caused	Error Reasons	Solutions
Actuator _1 is shorted to ground	115	P2670	The solenoid valve and indicating light connected to the whole vehicle; after treatment part is not considered	The relevant components cannot work	K94, K92, K50, K25, K26 and the whole vehicle voltage input	Check if the open-circuit voltage of K94, K92, K50, K25 and K26 is 3.5V; if not, check if it is shorted with other circuit
Actuator _2 is shorted to ground	116	P2685	The wiring harness of urea dosing pump	The urea pressure cannot be set by the urea dosing pump	There is voltage input of the whole vehicle for K93	Unplug the connector of the urea dosing pump to measure if the voltage of K93 at the ECU end is within 0-25mV; if not, check if K93 is shorted with other circuit
The voltage of the storage battery is too high	124	P0563	Alternator and storage battery	ECU is damaged, and the engine cannot be started	The voltage of the storage battery is too high	1. Check the storage battery; 2. Check the alternator; 3. Check the ECU
The voltage of the storage battery is too low	124	P0562	Alternator and storage battery	ECU does not work normally; and the engine is stopped	The voltage of the storage battery is too low	1. Check the storage battery; 2. Check the alternator; 3. Check the ECU
The voltage signal of storage battery is too high	124	P0563	Alternator and storage battery	ECU is damaged, and the engine cannot be started	The voltage signal of the storage battery is too high	1. Check the storage battery; 2. Check the alternator; 3. Check the ECU
The voltage signal of the storage battery is too low	124	P0562	Alternator and storage battery	ECU does not work normally; and the engine is stopped	The voltage of the storage battery is too low	1. Check the storage battery; 2. Check the alternator; 3. Check the ECU

Description	Flash codes	P-Code	Components Related	Problem caused	Error Reasons	Solutions
The main and auxiliary braking signals are not in the same condition	223	P0504	Brake or brake wiring harness	1. The braking cannot be judged; 2. Unable to achieve cruising; 3. Brake override failure	1. Failure of wiring harness of the main and auxiliary braking switch; 2. The main and auxiliary braking signals are out of sync	Check the main and auxiliary braking system (when the main brake is pressed, the K41 end voltage is 24V; and when the auxiliary brake is pressed, the K14 end voltage is 0V; and check if they are synchronous) as well as the related wiring harness (check the open-short state of the connector to K41 and K14)
Braking signal error	223	P0571	CAN message	Fault of the braking signal from the CAN bus	Fault of the braking switch and related wiring harness	Check the main and auxiliary braking system (when the main brake is pressed, the K41 end voltage is 24V; and when the auxiliary brake is pressed, the K14 end voltage is 0V; and check if they are synchronous) as well as the related wiring harness (check the open-short state of the connector to K41 and K14)
Fault of CAN node A bus	411	U0073	ECU/NOx sensor	The CAN bus communication does not work normally	The CAN module inside the ECU is damaged; and the NOx sensor is not well connected	Check the CAN bus 0 (K54/K76) and all related node fault, such as shorted to ground and open circuit (K54 to earth 2.7V; and K76 to earth 2.5V)
Turn off fault of CAN node A bus	411	U0073	ECU/NOx sensor	Saving flash code; when under the condition of BUS OFF, other nodes cannot communicate with A node	The CAN module inside the ECU is damaged; and the NOx sensor is not well connected	Check the connection of the NOx sensor
The steady-state temperature of the engine coolant is untrusted	242	P0116	Water temperature of the engine	Engine torque is limited; saving flash code	Fault of the water temperature sensor	Check the wiring harness of the engine temperature sensor; or replace the water temperature sensor



Description	Flash codes	P-Code	Components Related	Problem caused	Error Reasons	Solutions
The dynamic temperature of the engine coolant is untrusted	242	P0116				
The engine coolant temperature from the CAN signal is wrong	241	U0116	CAN bus	The water temperature cannot be obtained; saving flash code	There is no such message for the CAN bus; or the message is wrong	Check the address and content of the message
The original voltage of the engine coolant temperature is higher than the upper limit	241	P0118	Water temperature sensor	Engine torque is limited; and the MIL light is on	Wrong wire connection	Check the wire connection of the water temperature sensor
The original voltage of the engine coolant temperature is below the lower limit	241	P0117				
The engine coolant temperature is untrusted (the deviation of the temperature and the selected second temperature is higher than the upper limit)	242	P0116		Wrong engine water temperature	When start up, the water temperature does not reach the set value	
The clutch signal is untrusted (the gear is changed, but the clutch signal is not changed accordingly)	222	P0704	Clutch signal	The cruise cannot be exit by pressing the clutch pedal; and the fault light is on after three driving cruise	Bad clutch switch contact	Check the clutch switch and circuit

Description	Flash codes	P-Code	Components Related	Problem caused	Error Reasons	Solutions
Clutch signal from the CAN is wrong	222	U1400		The cruise cannot be entered; and the fault light is on after three driving cruise	The address and content of the message are wrong	Check the CAN controller
Activation fault of the OBD torque limiting	511	P1007	Torque limiter	Engine torque is limited	The multi-layer torque limiter works, but the display is wrong	Remove the fault causing torque limiting
Fault of the combination of the cruise control switch	341	P0575	Multi-function switch	The vehicle cannot enter the cruise state; saving fault code	Two or more keys of the multi-function switch are pressed at the same time	Check the switch condition and circuit
The voltage of the storage battery is too high	124	P0563	Storage battery	Completely turn off the power supply diagnosis of the actuator pin; and saving fault code	There is electric leakage for the storage battery; or poor contact of the circuit	Replace the storage battery/check the circuit
The voltage of the storage battery is too low	124	P0562				
The exhaust braking is untrusted	342	P1500	Exhaust braking solenoid valve	The exhaust braking does not work; and saving fault code	Fault of the exhaust braking solenoid valve and the exhaust braking circuit	Check the exhaust braking circuit; and replace the exhaust braking solenoid valve
The signal of the off-vehicle stop switch is untrusted	343	P2536	Off-vehicle stop switch	The off-vehicle stop function failure; and saving fault code	The pressing time for the off-vehicle stop switch is too long	Check if the switch is stuck; and check for short circuit
The signal of the off-vehicle start switch is untrusted	343	P2536	Off-vehicle start switch	The off-vehicle start function failure; and saving fault code	The pressing time for the off-vehicle start switch is too long	Check if the switch is stuck; and check for short circuit



Description	Flash codes	P-Code	Components Related	Problem caused	Error Reasons	Solutions
EEP erasure error	117	P062F	ECU internal memory	ECU fault, and saving fault code	ECU internal error	Switch off and restart, and replace the ECU
EEP read error	117	P062F		Error of the reading data, the replacing value is adopted; and saving fault code		
EEP writing error	117	P062F		ECU fault; saving fault code		
Fuel injection is cut off because of the engine shutdown request	512	P1008	The fuel injector, and the shutdown system of the engine	Engine is shut down; and the flash code light is on		
Engine is over speed	513	P0219	Speed controller of the engine	The engine is in limp home mode; saving flash code	The engine speed is over the maximum allowable value	Switch off and restart
Engine protection activated	514	P1009				
There is no load for the engine speed output	344	P100A	Engine speed output pin	The engine speed signal cannot be correctly obtained through the pin; saving flash code	There is short circuit or open circuit for the circuit connected with the speed output pin	Reconnect the circuit
The temperature engine speed output is too high	344	P100B				
The engine speed output is shorted to the power supply	344	P100C				

Description	Flash codes	P-Code	Components Related	Problem caused	Error Reasons	Solutions
The engine speed output is short-circuited to ground	344	P100D				
Fault of the environment pressure CAN information	232	U1401	Environment pressure sensor (inside the ECU)	The light of flash codes is always on; and the power is insufficient and there is black smoke in the plateau	The barometric pressure sensor inside the ECU is damaged	Replace ECU
The voltage of the environment pressure sensor is higher than the upper limit	232	P2229				
The voltage of the environment pressure sensor is below the lower limit	232	P2228				
The environment temperature is untrusted	235	P0071	Environment temperature sensor	The after treatment system does not work properly; saving fault code	The difference of the temperatures measured by the environment temperature sensor and the inlet air flow sensor is too large	Check the environment temperature sensor
The voltage of the environment temperature sensor is higher than the upper limit	235	P0073		The environment temperature sensor cannot be correctly obtained; the MIL light is on	The circuit is shorted to power supply or ground	Check the wiring harness of the environment temperature sensor
The voltage of the environment temperature sensor is less than the lower limit	235	P0072				
Fault of the cam shaft signal	123	P0341	Camshaft speed sensor	Difficult to start, the power is insufficient and the MIL light is on	The camshaft speed sensor is damaged	Check the wiring harness of the camshaft speed sensor

Description	Flash codes	P-Code	Components Related	Problem caused	Error Reasons	Solutions
Camshaft signal missing	123	P0340			The camshaft speed sensor is damaged; The circuit is shorted	Replace the camshaft speed sensor; and check the wiring harness of the speed sensor
Deviation fault of the cam shaft signal	123	P0340			Assembly problem of crankshaft and camshaft	Replace the camshaft speed sensor
Fault of the crankshaft signal	122	P0336			The installation of crankshaft speed sensor is wrong; there is open circuit for the wiring harness; and there is flywheel processing problems	Check the installation of the crankshaft speed sensor, wiring harness and the processing quality of the flywheel ring gear
Crankshaft signal missing	122	P0335	Speed sensor of crankshaft	Difficult to start, the engine power is insufficient		
There is no load for the exhaust braking solenoid valve	311	P0475		The exhaust braking cannot work; and the fault light is on after three driving cruise	The exhaust braking solenoid valve is not well connected	Check the circuit
The exhaust braking solenoid valve overheated	311	P0475	Exhaust braking solenoid valve		The exhaust braking solenoid valve is damaged	Replace the solenoid valve
The exhaust braking solenoid valve is shorted to power supply	311	P0478			The exhaust braking circuit is shorted	Check the exhaust braking circuit
The exhaust braking solenoid valve is shorted to ground	311	P0477			The exhaust braking circuit is shorted	
The state of exhaust braking solenoid valve is untrusted	311	P0476	Exhaust braking solenoid valve	The exhaust braking is disable	The detection pulse of exhaust braking solenoid valve is unqualified	1. Check the wiring of the exhaust braking solenoid valve (K29/K47); 2. Check if the exhaust braking solenoid valve is damaged
The state of exhaust braking solenoid valve is wrong	311	P0475	Exhaust braking solenoid valve	The exhaust braking is disable	The detection pulse of the exhaust braking solenoid valve is unqualified	1. Check the wiring of the exhaust braking solenoid valve (K29/K47); 2. Check if the exhaust braking solenoid valve is damaged

Description	Flash codes	P-Code	Components Related	Problem caused	Error Reasons	Solutions
There is no load for the fan solenoid valve 1	312	P0480	Electromagnetic fan	The coil 1 of the electromagnetic fan cannot work	The relay 1 of electromagnetic fan is not well connected	1. Check if it is of electromagnetic fan; 2. Check the connection of wiring harness; 3. Check if the electromagnetic fan is damaged
There is no load for the fan solenoid valve 2	312	P0480	Electromagnetic fan	The coil 2 of the electromagnetic fan cannot work	The relay 2 of electromagnetic fan is not well connected	1. Check if it is of electromagnetic fan; 2. Check the connection of wiring harness; 3. Check if the electromagnetic fan is damaged
The fan solenoid valve 1 is overheated	312	P0480	Electromagnetic fan	The coil 1 of electromagnetic fan cannot work	The relay of electromagnetic fan is damaged or the resistance is too low	1. Check if the relay of electromagnetic fan is damaged; 2. Check the matching (resistance) of the relay of electromagnetic fan; 3. Check if there is short circuit for the two control ends of the relay
The fan solenoid valve 2 is over the temperature	312	P0480	Electromagnetic fan	The coil 2 of electromagnetic fan cannot work	The relay of electromagnetic fan is damaged or the resistance is too low	1. Check if the relay of electromagnetic fan is damaged; 2. Check the matching (resistance) of the relay of electromagnetic fan; 3. Check if there is short circuit for the two control ends of the relay
The fan solenoid valve 1 is shorted to power supply	312	P0692	Electromagnetic fan	The coil 1 of electromagnetic fan cannot work	The control end of coil 1 is shorted to power supply	1. Unplug the connector of coil 1, check if the voltage of the control end is not equal to 0; 2. Check if the electromagnetic fan is damaged
The fan solenoid valve 2 is shorted to power supply	312	P0692	Electromagnetic fan	The coil 2 of electromagnetic fan cannot work	The control end of coil 2 is shorted to power supply	1. Unplug the connector of coil 2, check if the voltage of the control end is not equal to 0; 2. Check if the electromagnetic fan is damaged
The fan solenoid valve 1 is shorted to ground	312	P0691	Electromagnetic fan	The coil 1 of electromagnetic fan cannot work	The control end of coil 1 is shorted to ground	1. Unplug the connector of coil 1, measure if the resistance between the control end and the public ground wire is not infinite



Description	Flash codes	P-Code	Components Related	Problem caused	Error Reasons	Solutions
The fan solenoid valve 2 is shorted to ground	312	P0691	Electromagnetic fan	The coil 2 of electromagnetic fan cannot work	The control end of coil 2 is shorted to ground	1. Unplug the connector of coil 2, measure if the resistance between the control end and the public ground wire is not infinite
There is no load for fan PWM drive	312	P0481	Electronic controlled silicon oil fan	The fan cannot work	Open circuit of the solenoid valve of electronic controlled silicon oil fan	1. Check if it is of electronic controlled silicon oil clutch; 2. Check if the wiring harness and connector are connected properly; 3. Check if the electronic controlled silicon oil clutch is damaged
The PWM drive of the fan is overheated	312	P0481	Electronic controlled silicon oil fan	The fan cannot work	The coil of the electronic controlled fan is damaged	The 24V relay is used to test if there is any other fault, if not, replace the fan clutch
The PWM drive of the fan is shorted to power supply	312	P0694	Electronic controlled silicon oil fan	The fan cannot work	The PWM signal end of electronic controlled silicon oil fan solenoid valve is shorted to power supply	1. Check if it is of electronic controlled silicon oil clutch; 2. Check if the PWM end of the fan relay is shorted to power supply; 3. Check if the electronic controlled silicon oil clutch is damaged
The PWM drive of the fan is shorted to ground	312	P0693	Electronic controlled silicon oil fan	The fan cannot work	The PWM signal end of electronic controlled silicon oil fan solenoid valve is shorted to ground	1. Check if it is of electronic controlled silicon oil clutch; 2. Check if the PWM end of the fan relay is shorted to ground; 3. Check if the electronic controlled silicon oil clutch is damaged
The fan speed signal interval is too long	316	P0480	Electronic controlled silicon oil fan	There is no fan speed	The interval time of the two pulses of fan speed is too short	1. Check if the electronic controlled silicon oil clutch can be rotated under normal condition; 2. Check if the speed sensor of silicon oil clutch is damaged
The fan speed is higher than the maximum value	316	P0495	Electronic controlled silicon oil fan	The fan speed is incorrect	The sensor is damaged or the data cannot match	1. Check if the speed sensor of electronic controlled silicon oil fan is damaged; 2. Check if the drive ratio of the fan and the crankshaft is too large; 3. Check the data

Description	Flash codes	P-Code	Components Related	Problem caused	Error Reasons	Solutions
The fan speed is lower than	316	P0494	Electronic controlled	The fan speed is incorrect	The sensor is damaged or the	1. Check if the speed sensor of electronic controlled

the minimum value			silicon oil fan		data cannot match	silicon oil fan is damaged; 2. Check if the drive ratio of the fan and the crankshaft is too small; 3. Check the data
The voltage signal of water-in-fuel sensor is higher than the upper limit	214	P2267	Primary filter or fuel system protector	Saving flash code	The sensor is not connected	Note: The fault when the analog signal is used by the water-in-fuel sensor; at present, there is no such fault
The voltage signal of water-in-fuel sensor is less than the lower limit	214	P2266	Primary filter or fuel system protector	Saving flash code	The signal circuit of the sensor is shorted to ground	Note: The fault when the analog signal is used by the water-in-fuel sensor; at present, there is no such fault
There is too much water in the fuel	211	P2269	Primary filter or fuel system protector	Diesel fuel entering the engine contains too much water	The water level of the water cup on the primary filter is high	Drain water from the water cup on primary fuel filter
The CAN input signal of neutral gear is wrong	227	U1402	Signal of neutral gear	Saving flash code	The neutral gear status obtained from the CAN bus is incorrect	There is no such fault at present; if any, it shall be closed in the program
There is no load for the inlet air heating light	332	P0381	Inlet air heating light	There is no action for the inlet air heating light	The inlet air heating light is not connected or the circuit is open circuit	1. Check if the inlet air heating light is connected or damaged; 2. Check if the circuit is connected with the ECU (K68/K48)
Inlet air heating light is overheated	332	P0381	Inlet air heating light	There is no action for the inlet air heating light	Improper matching of the inlet air heating light or there is something wrong with the circuit	1. Check the matching (resistance) of the inlet air heating light
The inlet air heating light is shorted to power supply	332	P0381	Inlet air heating light	There is no action for the inlet air heating light	Wiring problem of the inlet air heating light	1. Check if the signal end K48 of the inlet air heating light is shorted to power supply
The inlet air heating light is shorted to ground	332	P0381	Inlet air heating light	There is no action for the inlet air heating light	Wiring problem of the inlet air heating light	1. Check if the signal end K48 of the inlet air heating light is shorted to ground (ground connection)

Description	Flash codes	P-Code	Components Related	Problem caused	Error Reasons	Solutions
There is no load for the inlet air heating	321	P0110	Inlet air heating relay	Inlet air heating failure	The inlet air heating relay is not connected or the circuit is open circuit	1. Check the connection of inlet air heating relay, and check if it is connected with ECU (K68/K72); 2. Check if the inlet air heating relay is damaged
The inlet air heating is overheated	321	P0110	Inlet air heating relay	Inlet air heating failure	Improper matching of the inlet air heating relay or there is something wrong with the circuit	1. Check the matching (resistance) of inlet air heating relay
The inlet air heating is shorted to power supply	321	P0113	Inlet air heating relay	Inlet air heating failure	Wiring problem of the inlet air heating relay	1. Check if the control end K72 of the inlet air heating relay is shorted to power supply
The inlet air heating is shorted to ground	321	P0112	Inlet air heating relay	Inlet air heating failure	Wiring problem of the inlet air heating relay	1. Check if the control end K72 of the inlet air heating relay is shorted to ground
Description	Flash codes	P-Code	Components Related	Problem caused	Error Reasons	Solutions
The fuel injection number is over the limit of drive circuit	324	P100E	ECU	The fault light is on	The ECU supply voltage is low	1. Check the electric quality and power supply situation of the battery; 2. Check the alternator status
The fuel injection number is over the limit of injection pump	324	P100F	Injection pump and common rail	The fault light is on	The flow of injection pump is too large; and the positive deviation of rail pressure is over 50MPa	1. Check if there is fault for the flow measuring unit
The fuel injection number is over the limit of the system	324	P1010	ECU	The fault light is on	The injection number is more than 5 times	Check the data calibration
The fuel injection number is over the limit of the system	324	P1011	ECU	The fault light is on	The injection number is more than 5 times	Check the data calibration

Description	Flash codes	P-Code	Components Related	Problem caused	Error Reasons	Solutions
The rail pressure is lower than the minimum value	276	P0087	ECU/fuel injector	The fault light is always on	The rail pressure is lower than the minimum fuel injection pressure	Check the fuel injector; replace ECU
The fuel injection capacitor 1 is shorted	151	P062D	Fuel injector	The fault light is always on	There is short circuit for the fuel injector wiring harness of cylinder 1, 2 and 3	1. Check if there is ground connection for the fuel injector wiring harness of cylinder 1, 2 and 3; 2. Check if the wiring harness at the fuel injector binding post is loose
The fuel injection capacitor 2 is shorted	151	P062E	Fuel injector	The fault light is always on	There is short circuit for the fuel injector wiring harness of cylinder 4, 5 and 6	1. Check if there is ground connection for the fuel injector wiring harness of cylinder 4, 5 and 6; 2. Check if the wiring harness at the fuel injector binding post is loose
Failure of special chip for fuel injection	153	P062B	ECU	Engine flameout	ECU CY33X chip failure	Replace ECU
The fuel injector 1 is open circuit	141	P0201	Fuel injector	The OBD light is always on; and there is misfire	The wiring harness of the fuel injector of cylinder 1 is not well connected	1. Check the connection of binding post of cylinder 1 fuel injector; 2. Check if the connector A33 or A16 of the wiring harness is well connected with the ECU pin
The fuel injector 2 is open circuit	142	P0205	Fuel injector	OBD light is always on; and there is misfire	The wiring harness of the fuel injector of cylinder 2 is not well connected	1. Check if the connection of the binding post of the cylinder 2 fuel injector; 2. Check if the connector A48 or A18 of the wiring harness is well connected with the ECU pin
The fuel injector 3 is open circuit	143	P0203	Fuel injector	OBD light is always on; and there is misfire	The wiring harness of the fuel injector of cylinder 3 is not well connected	1. Check if the connection of the binding post of the cylinder 3 fuel injector; 2. Check if the connector A47 or A17 of the wiring harness is well connected with the ECU pin



Description	Flash codes	P-Code	Components Related	Problem caused	Error Reasons	Solutions
The fuel injector 4 is open circuit	144	P0206	Fuel injector	OBD light is always on; and there is misfire	The wiring harness of the fuel injector of cylinder 4 is not well connected	1. Check if the connection of the binding post of the cylinder 4 fuel injector; 2. Check if the connector A46 or A03 of the wiring harness is well connected with the ECU pin
The fuel injector 5 is open circuit	145	P0202	Fuel injector	OBD light is always on; and there is misfire	The wiring harness of the fuel injector of cylinder 5 is not well connected	1. Check if the connection of the binding post of the cylinder 5 fuel injector; 2. Check if the connector A31 or A01 of the wiring harness is well connected with the ECU pin
The fuel injector 6 is open circuit	146	P0204	Fuel injector	OBD light is always on; and there is misfire	The wiring harness of the fuel injector of cylinder 6 is not well connected	1. Check if the connection of the binding post of the cylinder 6 fuel injector; 2. Check if the connector A32 or A02 of the wiring harness is well connected with the ECU pin
The fuel injector 1 is shorted	141	P0262	Fuel injector	OBD light is always on; and there is misfire	1. The high end and low end of corresponding fuel injector are shorted; 2. The corresponding fuel injector is shorted to power supply	Check the wiring harness of corresponding fuel injector
The fuel injector 2 is shorted	142	P0274	Fuel injector	OBD light is always on; and there is misfire		
The fuel injector 3 is shorted	143	P0268	Fuel injector	OBD light is always on; and there is misfire		
The fuel injector 4 is shorted	144	P0277	Fuel injector	OBD light is always on; and there is misfire		



Description	Flash codes	P-Code	Components Related	Problem caused	Error Reasons	Solutions
The fuel injector 5 is shorted	145	P0265	Fuel injector	OBD light is always on; and there is misfire	The low end and high end of corresponding fuel injector are shorted	Check the wiring harness of corresponding fuel injector
The fuel injector 6 is shorted	146	P0271	Fuel injector	OBD light is always on; and there is misfire		
The low end and high end of fuel injector 1 are shorted	141	P0261	Fuel injector	OBD light is always on; and there is misfire		
The low end and high end of fuel injector 2 are shorted	142	P0273	Fuel injector	OBD light is always on; and there is misfire		
The low end and high end of fuel injector 3 are shorted	143	P0267	Fuel injector	OBD light is always on; and there is misfire		
The low end and high end of fuel injector 4 are shorted	144	P0276	Fuel injector	OBD light is always on; and there is misfire		
The low end and high end of fuel injector 5 are shorted	145	P0264	Fuel injector	OBD light is always on; and there is misfire		
The low end and high end of fuel injector 6 are shorted	146	P0270	Fuel injector	OBD light is always on; and there is misfire		
The PTO switch voltage is higher than the upper limit	345	P251C	Fuel-saving switch	Saving flash code	The fuel-saving switch is not connected properly	1. Remove the fuel-saving switch; check if the voltage of the ECU end K79 is 5V; 2. Check the connection of K79, K74 and the pin of fuel-saving switch

Description	Flash codes	P-Code	Components Related	Problem caused	Error Reasons	Solutions
Poor contact of ECU and fuel metering unit	133	P0251	Fuel metering unit	The flash code light is always on; and the engine is in limp home mode	Poor connection of wiring harness of fuel metering unit	Check if the wiring harness of fuel metering unit is reliable fixed
The fuel metering unit is open circuit	133	P0251	Fuel metering unit	The flash code light is always on; and the engine is in limp home mode	Poor connection of fuel metering unit	1. Plug the connector of fuel metering unit; 2. Check if the wiring harness is open circuit
The fuel metering unit is overheated	133	P0252	Fuel metering unit	The flash code light is always on; and the engine is in limp home mode	The fuel metering unit is damaged	Replace the fuel metering unit
The higher end of fuel metering unit is shorted to power supply	133	P0254	Fuel metering unit	The light of flash codes is always on; and the engine is in limp home mode	A04 voltage is higher than the voltage of the storage battery	Check the circuit connection of A04; Unplug the fuel metering unit connector; the voltage shall be 24V
The higher end of the fuel metering unit is shorted to ground	133	P0253	Fuel metering unit	The light of flash codes is always on; and the engine is in limp home mode	A04 voltage is shorted to ground	Check if there is ground connection for A04 wiring harness; Unplug the fuel metering unit connector; the voltage shall be 24V
The lower end driving of fuel metering unit is shorted to power supply	133	P0254	Fuel metering unit	The light of flash codes is always on; and the engine is in limp home mode	A04 is shorted to power supply	1. Unplug the fuel metering unit connector; measure the A05 voltage, the voltage shall be 3.5V
The lower end driving of fuel metering unit is shorted to ground	133	P0253	Fuel metering unit	The light of flash codes is always on; and the engine is in limp home mode	A04 is shorted to ground	1. Unplug the fuel metering unit connector; measure the A05 voltage, the voltage shall be 3.5V
The voltage signal for the current feedback of fuel metering unit is higher than the upper limit	133	P0254	Fuel metering unit	The light of flash codes is always on; and the engine is in limp home mode	Poor connection of fuel metering unit	1. 1. Unplug the fuel metering unit connector; measure the A05 voltage, the voltage shall be 3.5V; and the voltage of A04 shall be 24V

Description	Flash codes	P-Code	Components Related	Problem caused	Error Reasons	Solutions
The voltage signal for the current feedback of fuel metering unit is less than the lower limit	133	P0253	Fuel metering unit, pressure-limiting valve, common rail pipe and fuel line	Limp home	The pressure-limiting valve is open, the fuel line is damaged or the fuel inlet is blocked	1. Check the pressure-limiting valve; 2. Check the fuel line
There is no load for the MIL light	331	P0650	OBD light	The OBD malfunction indicator light does not function correctly	1. The MIL light is not connected or is damaged; 2. Single-end control	1. Check if the MIL light; 2. Close the MIL light diagnosis control
MIL light is overheated	331	P0650	OBD light	The OBD malfunction indicator light does not function correctly	The drive circuit of OBD malfunction indicator light is overloaded	Check OBD malfunction indicator light and circuit
MIL light is shorted to the power supply	331	P0650	OBD light	The OBD malfunction indicator light does not function correctly	The drive circuit of OBD malfunction indicator light is shorted to power supply	1. Check the circuit between MIL light and power supply with multimeter; 2. Rewiring
MIL light is shorted to ground	331	P0650	OBD light	The OBD malfunction indicator light does not function correctly	The drive circuit of OBD malfunction indicator light is shorted to ground	1. Check if there is ground connection for MIL light circuit with multimeter; 2. Rewiring
PTO switch voltage is less than the lower limit (multi-state switch)	345	P251B	Multi-state switch and its wiring harness and connector	The multi-state switch cannot be used	1. The fuse is damaged; the wiring harness is damaged; or the connector is damaged; 2. The switch is damaged	1. Check the power supply; 2. Check the circuit; 3. Check switch resistance
Digital-to-analog conversion error	262	P060B	ECU	Engine malfunction	ECU internal fault	Replace ECU

Description	Flash codes	P-Code	Components Related	Problem caused	Error Reasons	Solutions
Digital-to-analog conversion error	262	P060B	ECU	Engine malfunction	ECU internal fault	Replace ECU
Analog-to-analog conversion ratio coefficient error	262	P060B	ECU	Engine malfunction	ECU internal fault	Replace ECU
Communication error between CPU and monitoring module	262	P060C	ECU	Engine malfunction	ECU internal fault	Replace ECU
ECU memory error	262	P060C	ECU	Engine malfunction	ECU internal fault	Replace ECU
Communication error between CPU and monitoring module	263	P060C	ECU	Engine malfunction	ECU internal fault	Replace ECU
The two voltages of accelerator pedal are different	264	P1012	Accelerator pedal, Wiring harness, ECU	Accelerator pedal fault	Accelerator pedal fault, ECU internal fault	1. Check whether the relationship of APP1 voltage and APP2 voltage of remote accelerator pedal is of double; 2. Replace accelerator pedal; 3. Check the wiring harness of accelerator pedal for short circuit/open circuit; 4. Replace ECU
The engine speed is untrusted	264	P1013	Speed signal	The fault light is always on		
The power-on time of fuel injector is untrusted	264	P1014	ECU/fuel injector	The fault light is always on	ECU internal fault	Turn off the power of the vehicle for more than 30s, and check whether the next driving cycle is normal. 2. Replace ECU
Injection advance angle is untrusted	264	P1015		The fault light is always on		

Description	Flash codes	P-Code	Components Related	Problem caused	Error Reasons	Solutions
The power-on time during OverRun is more than the maximum value	261	P101A	ECU	The fault light is always on	ECU internal fault	1. Turn off the power of the vehicle for more than 30s, and check whether the next driving cycle is normal. 2. Replace ECU
The power-on time of fuel injector during Overrun is more than the maximum allowed value (overheating protection to fuel injector)	261	P101A	ECU	The fault light is always on	ECU internal fault	1. Turn off the power of the vehicle for more than 30s, and check whether the next driving cycle is normal. 2. Replace ECU
Rail pressure error	264	P101C	Rail pressure sensor, high pressure fuel pump, flow metering unit, high pressure fuel line, low pressure fuel line	Affect the normal operation of the vehicle or limp home	Fault of related parts above	Check the related parts above
Two voltages of remote accelerator pedal are different	264	P1045	Remote accelerator pedal, wiring harness, ECU	Remote accelerator pedal fault	Remote accelerator pedal fault, ECU internal fault	1. Check whether the relationship of APP1 voltage and APP2 voltage of remote accelerator pedal is of double; 2. Replace remote accelerator pedal 3. Check the related wiring harness of the remote pedal for short circuit or open circuit fault; 4. Replace ECU

Description	Flash codes	P-Code	Components Related	Problem caused	Error Reasons	Solutions
The voltage of power supply module 1 exceeds the upper limit	265	P1600	ECU, storage battery, alternator	ECU cannot operate normally, affecting the normal operation	The supply voltage of supply 1 is over high	1. Check whether the 30A fuse of power module 1; 2. Check related wiring harness; 3. Check the storage battery and alternator of the vehicle 4. Replace ECU
The voltage of power supply module 1 is less than the lower limit	265	P1601	ECU, storage battery, alternator	ECU cannot operate normally, affecting the normal operation	The supply voltage of supply 1 is too low	1. Check whether the 30A fuse of power module 1; 2. Check related wiring harness; 3. Check the storage battery and alternator of the vehicle 4. Replace ECU
Main relay opened early after ECU is powered on	125	P068A	ECU	Saving fault code	ECU main relay malfunction	1. Check ECU; 2. Replace ECU
Main relay cannot be disconnected	125	P068B	ECU	Saving fault code	ECU main relay malfunction	1. Check ECU; 2. Replace ECU
Oil pressure signal error	243	P0524	Digital oil pressure sensor	Flash code light is on after 3 driving cycles and the engine is in limp home mode	Oil pressure is low	Weichai engine does not use a digital oil pressure sensor and the fault should be closed in the program
The oil pressure signal is untrusted	243	P0521	Digital oil pressure sensor	Flash code light is on after 3 driving cycles and the engine is in limp home mode	After engine is stopped, the oil pressure still exist	Weichai engine does not use a digital oil pressure sensor and the fault should be closed in the program



Description	Flash codes	P-Code	Components Related	Problem caused	Error Reasons	Solutions
The oil pressure is higher than the upper limit	243	P0523	Analog oil pressure sensor	Saving flash code and the engine is in limp home mode	The oil pressure is over high	1. Check the oil pressure with a diagnostic apparatus (for WP10/WP12, the permissible maximum pressure is 7800hPa; for WP7, it is 10000hPa); 2. Replace oil pressure sensor; 3. Check the oil pump and the oil passage pressure relief valve for damage
Oil pressure is less than the lower limit	243	P0524	Analog oil pressure sensor	Saving flash code and the engine is in limp home mode	Oil pressure is too low	1. Check the oil pressure, the allowable minimum value is 1600hPa; 2. Replace oil pressure sensor; 3. Check the oil pump and the oil passage pressure relief valve for damage
CAN signal error of oil pressure	243	P0520	Analog oil pressure sensor	Saving flash code and the engine is limp home mode	The fault is not closed in the program, the oil pressure signal is connected to ECU through real sensor	Flash the program and close the fault
Voltage signal of oil pressure is higher than the upper limit	243	P0523	Analog oil pressure sensor	Saving flash code, the flash code light is on after 3 driving cycles	The voltage of pin A44 is higher than 4.5V	1. Pin A44 is not well connected to the sensor; 2. The pin A44 is shorted to the power line of more than 5V
The voltage signal of oil pressure is less than the lower limit	243	P0522	Analog oil pressure sensor	Saving flash code, the flash code light is on after 3 driving cycles	The voltage of pin A44 is lower than 215mV	The pin A44 is shorted to ground wire

Description	Flash codes	P-Code	Components Related	Problem caused	Error Reasons	Solutions
Oil temperature signal is higher than the upper limit	244	P0196	Oil temperature sensor	Saving flash code	The oil temperature is more than the allowable value 125°C	1. Check whether the actual oil temperature is over high; 2. Replace oil temperature sensor
Oil temperature CAN signal error	244	U1403	Oil temperature sensor	Saving flash code	The oil temperature gained from CAN bus is 0°C	ECU does not obtain the oil temperature from CAN bus, flash the program and close the fault
The voltage signal of oil temperature is higher than the upper limit	244	P0198	Oil temperature sensor	Saving flash code, the flash code light is on after 3 driving cycles	The voltage of pin A59 is higher than 4.97V	1. Pin A59 is not well connected to the sensor; 2. Pin A59 is shorted to the power line of more than 5V
The voltage signal of oil temperature is less than the lower limit	244	P0197	Oil temperature sensor	Saving flash code	The voltage of pin A59 is lower than 144mV	Pin A59 is shorted to the ground wire
The oil temperature signal is untrusted	244	P0196	Oil temperature sensor	Saving flash code	The difference value between oil temperature and other temperature exceeds the allowable value	1. Monitor whether the oil temperature, water temperature and inlet air temperature is abnormal; 2. Check the corresponding sensor according to the monitored result above
Non-monotonically conversion of oil amount torque	245	P1031	Calibration data of ECU	Saving flash code	Non-monotonic data calibration	Contact the Weichai headquarters, check data and flash data again after correction
Upstream inlet air pressure signal is higher than the upper limit	231	P006D	Upstream inlet air pressure	Saving flash code	Inlet air pressure is 200hpa higher than the atmospheric pressure during parking	1. Check whether the atmospheric pressure value is consistent with the local atmospheric pressure, if the difference is too large, replace the ECU; 2. Check whether the inlet air pressure value is consistent with the local atmospheric pressure, if the difference is too large, replace the sensor

Description	Flash codes	P-Code	Components Related	Problem caused	Error Reasons	Solutions
The upstream inlet air pressure signal is less than the lower limit	231	P006D	Upstream inlet air pressure	Saving flash code	Inlet air pressure is 200hPa lower than the atmospheric pressure	1. Check whether the atmospheric pressure value is consistent with the local atmospheric pressure, if the difference is too large, replace the ECU; 2. Check whether the inlet air pressure value is consistent with the local atmospheric pressure, if the difference is too large, replace the sensor
The voltage signal of upstream inlet air pressure is higher than the upper limit	231	P0238	Upstream inlet air pressure	Saving flash code and the engine is in limp home mode	The voltage of pin A43 is higher than 4.92V	1. The pin A43 is not well connected to sensor; 2. The pin A43 is shorted to power line of more than 5V
The voltage signal of upstream inlet air pressure is less than the lower limit	231	P0237	Upstream inlet air pressure	Saving flash code and the engine is in limp home mode	The voltage of pin A43 is lower than 202mV	The pin A43 is shorted to ground wire
The pressure-limiting valve is opened up to or above the maximum number	134	P0089	Fuel line	Flash code light always on	The number of times that the pressure inside the common-rail pipe exceeds the allowable value is more than 50	Check the fuel return line for bending and blocking; check whether the flow metering unit is always open; check the rail pressure sensor
The rail pressure is over large leading to open the pressure-limiting valve	137	P0089	Fuel line	The engine is in limp home mode	The pressure inside common-rail pipe exceeds the allowable value	Check the fuel return line for bending and blocking; check whether the flow metering unit is always open; check the rail pressure sensor
Rail pressure oscillation causing the pressure-limiting valve is open	138	P0089	Fuel line	The engine is in limp home mode	The pressure inside common-rail pipe exceeds the allowable value	Check the fuel return line for bending and blocking; check whether the flow metering unit is always open; check the rail pressure sensor

Description	Flash codes	P-Code	Components Related	Problem caused	Error Reasons	Solutions
Pressure-limiting valve open	135	P0089	Fuel line	The light of flash codes is always on; and the engine is in limp home mode	The pressure inside common-rail pipe exceeds the allowable value	Check the fuel return line for bending and blocking; check whether the flow metering unit is always open; check the rail pressure sensor
Fuel balancing error when the pressure-limiting valve is open	136	P1036	Fuel line	The flash code light is always on; and the engine is in limp home mode	The pressure fluctuation of common-rail pipe exceeds the allowable value	Check the fuel return line for bending and blocking; check whether the flow metering unit is always open; check the rail pressure sensor, whether there is rail pressure for a long time when the engine is stopped, if any, replace the common-rail pipe
The average rail pressure exceeds the allowable range	136	P1037	Fuel line	The flash code light is always on; and the engine is in limp home mode		
The opening time of pressure-limiting valve reached the limit	136	P0089	Fuel line	The flash code light is always on; and the engine is in limp home mode	The pressure inside common-rail pipe continuously exceeds the allowable value	Check the fuel return line for bending and blocking; check whether the flow metering unit is always open; check the rail pressure sensor
ECU internal power supply monitoring module error	111	P060C	ECU	Flash code light is always on	ECU internal fault	Replace ECU
The positive deviation of rail pressure controller is higher than the upper limit	251	P0251	Fuel line	The flash code light is always on; and the engine is in limp home mode	The pressure inside common-rail pipe exceeds the allowable value	Check the fuel return line for bending and blocking; check whether the flow metering unit is always open; check the rail pressure sensor
The fuel delivery of high-pressure pump is higher than the upper limit, it is leaking	252	P0251	Fuel line	The flash code light is always on; and the engine is in limp home mode	The pressure inside common-rail pipe exceeds the allowable value	Check the fuel return line for bending and blocking; check whether the flow metering unit is always open; check the rail pressure sensor

Description	Flash codes	P-Code	Components Related	Problem caused	Error Reasons	Solutions
In case of small fuel delivery, the negative deviation of rail pressure controller is higher than the limiting value of Stage I	255	P0251	Fuel line	The flash code light is always on; and the engine is in limp home mode	The pressure inside common-rail pipe exceeds the allowable value	Check the fuel return line for bending and blocking; check whether the flow metering unit is always open; check the rail pressure sensor
In case of small fuel delivery, the negative deviation of rail pressure controller is higher than the limiting value of Stage II	253	P0251				
The rail pressure is less than the lower limit	256	P0087	High pressure fuel line, low pressure fuel line	Hard starting, engine is in limp home state, pressure-limiting valve open, severe leakage of high pressure fuel, the oil return temperature increased	The intake resistance is too large; there is leakage on fuel inlet pipe; the fuel return resistance is too large	Check the fuel line of the engine, and replace filter and fuel pipe when necessary
The rail pressure is higher than the limiting value of Stage I	271	P0088	Flow metering unit and its wiring harness	Limp home	Flow metering unit always open, due to the wrong connection of wiring harness leading to no power supply for flow metering unit, the zero flow orifice blocked	Check zero flow orifice, flow metering unit and its wiring harness

Description	Flash codes	P-Code	Components Related	Problem caused	Error Reasons	Solutions
The rail pressure is higher than the limiting value of Stage II	272	P0088	Flow metering unit and its wiring harness	Limp home	Flow metering unit always open, due to the wrong connection of wiring harness leading to no power supply for flow metering unit, the zero flow orifice blocked	Check zero flow orifice, flow metering unit and its wiring harness
When it is at OverRun, the setting fuel supply of high-pressure fuel pump is higher than the upper limit	273	P1050	High-pressure fuel pump, fuel injector, pressure-limiting valve	Limp home	Fuel injector, pressure-limiting valve always open	Check the fuel line of engine (high pressure fuel line, low pressure fuel line)
The setting fuel supply of high-pressure fuel pump is higher than the upper limit when at low idling speed	274	P0251	High-pressure fuel pump, fuel injector, pressure-limiting valve	Limp home	Fuel injector, pressure-limiting valve always open	Check the fuel line of engine (high pressure fuel line, low pressure fuel line)
The times of rail pressure change exceeds the upper limit is higher than the maximum limit	275	P0194	Pressure relief valve of common-rail pip, low pressure fuel line	Causing the pressure relief valve always open or open for a long time, the pressure relief valve is damaged	The low pressure fuel line is not smooth (including fuel inlet and fuel return)	Replace common-rail pipe
The positive deviation of rail pressure is higher than the upper limit	132	P0191	High pressure fuel line, low pressure fuel pipe	Hard starting, limp home, pressure-limiting valve opened, severe leakage of high pressure fuel, oil return temperature increased	Flow metering unit always open, due to the wrong connection of wiring harness leading to no power supply for flow metering unit, the zero flow orifice blocked	Check zero flow orifice, flow metering unit and its wiring harness

Description	Flash codes	P-Code	Components Related	Problem caused	Error Reasons	Solutions
The negative deviation of rail pressure is less than the lower limit	132	P0191	High pressure fuel line, low pressure fuel pipe	Hard starting, limp home, pressure-limiting valve opened, severe leakage of high pressure fuel, oil return temperature increased	The intake resistance is too large; fuel inlet pipe leaked; the oil return resistance is too large	Check the fuel line of the engine, replace filter and fuel pipe when necessary
The rail pressure exceeds the maximum allowable value	136	P0088	High pressure fuel line, low pressure fuel line	Limp home	Pressure-limiting valve or overflow valve is damaged; fuel return pipe blocked	Check pressure-limiting valve, overflow valve, fuel return pipe
Voltage signal of rail pressure sensor exceeds the upper limit	131	P0193	Rail pressure sensor and its wiring harness	Limp home	Rail pressure sensor is damaged or its wiring harness is damaged or wrongly connected	Check rail pressure sensor and its wiring harness
The voltage signal of rail pressure sensor is less than the lower limit	131	P0192	Rail pressure sensor its wiring harness	Limp home	Rail pressure sensor is damaged or its wiring harness is damaged or wrongly connected	Check rail pressure sensor and its wiring harness
Urea injection adjustment amount error	434	P203B				
CAN information error of PTO switch	345	U1404	Multi-state switch and its wiring harness and connector	The status of multi-state switch is incorrect	The controller for sending fuel-saving switch state to ECU is incorrect	Check the controller
The voltage of pedal 1 is higher than the upper limit	221	P0123	Accelerator pedal	Limp home	Accelerator pedal or the connectors of its wiring harness is damaged	Check wiring harness connector or replace accelerator pedal

Description	Flash codes	P-Code	Components Related	Problem caused	Error Reasons	Solutions
The voltage of pedal 2 is higher than the upper limit	221	P0223	Accelerator pedal	Limp home	Accelerator pedal or the connector of its wiring harness is damaged	Check wiring harness connector or replace accelerator pedal
The voltage of remote pedal 1 is higher than the upper limit	229	P1501	Remote accelerator pedal	Enter into limp home state when using remote accelerator pedal	Accelerator pedal or the connector of its wiring harness is damaged	Check wiring harness connector or replace accelerator pedal
The voltage of remote pedal 2 is higher than the upper limit	229	P1502	Remote accelerator pedal	Enter into limp home state when using remote accelerator pedal	Accelerator pedal or the connector of its wiring harness is damaged	Check wiring harness connector or replace accelerator pedal
The voltage of pedal 1 is less than the lower limit	221	P0122	Accelerator pedal	Limp home	Accelerator pedal or the connector of its wiring harness is damaged	Check wiring harness connector or replace accelerator pedal
The voltage of pedal 2 is less than the lower limit	221	P0222	Accelerator pedal	Limp home	Accelerator pedal or the connector of its wiring harness is damaged	Check wiring harness connector or replace accelerator pedal
The voltage of remote pedal 1 is less than the lower limit	229	P1503	Remote accelerator pedal	Enter into limp home state when using remote accelerator pedal	Accelerator pedal or the connector of its wiring harness is damaged	Check wiring harness connector or replace accelerator pedal
The voltage of remote pedal 2 is less than the lower limit	229	P1504	Remote accelerator pedal	Enter into limp home state when using remote accelerator pedal	Accelerator pedal or the connector of its wiring harness is damaged	Check wiring harness connector or replace accelerator pedal



Description	Flash codes	P-Code	Components Related	Problem caused	Error Reasons	Solutions
The voltage of urea liquid level sensor is higher than the upper limit	445	P203D	Urea liquid level sensor		The urea liquid level sensor or wiring harness connector is damaged	Check the urea liquid level sensor or the wiring harness connector
The voltage of urea level sensor is less than the lower limit	445	P203C	Urea liquid level sensor		The urea liquid level sensor or wiring harness connector is damaged	Check the urea liquid level sensor or the wiring harness connector
Sensor power supply 1 error	112	P0643	ECU internal sensor power module	The power of engine is insufficient, black smoking	ECU internal error or power supply error of fan speed sensor, accelerator pedal 2 sensor, oil pressure/temperature sensor, intake pressure/temperature sensor, shorted to vehicle power or ground	Check the voltages of corresponding wiring harness of each sensor and ECU pin for abnormal
Sensor power supply 2 error	112	P0653	ECU internal sensor power module	The power of engine is insufficient, black smoking	The power supply error of accelerator pedal 1 sensor, shorted to vehicle power or ground	Check the voltages of corresponding wiring harness of each sensor and ECU pin for abnormal
Sensor power supply 3 error	112	P0699	ECU internal sensor power module	The power of engine is insufficient, black smoking	The power of rail pressure sensor or DNOX module is shorted to vehicle power or ground	Check the voltages of corresponding wiring harness of each sensor and ECU pin for abnormal

Description	Flash codes	P-Code	Components Related	Problem caused	Error Reasons	Solutions
No load on the starter drive	121	P0615	Starting relay and its wiring harness	Engine cannot be started	The wiring harness of starter relay is open circuit or wrongly connected, or the starter relay is damaged	Check starter relay and its wiring harness
The temperature of starter drive is too high	121	P0615	Starter relay and its wiring harness	Engine cannot be started	The wiring harness of starter relay is short circuit or wrongly connected, or the starter relay is damaged	Check starter relay and its wiring harness
Starter relay is shorted to power supply	121	P0617	Starter relay wiring harness	Engine cannot be started	The wiring harness of the starter relay is damaged or wrongly connected	Check the wiring harness of the starter relay
Starter relay is short-circuited to ground	121	P0616	Starter relay wiring harness	Engine cannot be started	The wiring harness of the starter relay is damaged or wrongly connected, check whether the relay is equipped with diode and is conductive	Check the wiring harness of the starter relay
No load on the diagnostic light drive	333	P1604	Diagnostic light and its wiring harness	The indication function of diagnostic light cannot be realized	The wiring harness of diagnostic light is open circuit or wrongly connected or the diagnostic light is damaged	Check diagnostic light and its wiring harness
The temperature of diagnostic light drive is too high	333	P1605	Diagnostic light and its wiring harness	Diagnostic indicating light power supply stopped	The wiring harness of diagnostic light is short circuit or wrongly connected or the diagnostic light is damaged	Check the wiring harness of diagnostic light

Description	Flash codes	P-Code	Components Related	Problem caused	Error Reasons	Solutions
Diagnostic light drive is shorted to power supply	333	P1606	Diagnostic light wiring harness	The indication function of diagnostic light cannot be realized	Diagnostic light wiring harness is damaged or wrongly connected	Check the wiring harness of diagnostic light
Diagnostic light drive is shorted to ground	333	P1607	Diagnostic light wiring harness	The indication function of diagnostic light cannot be realized	Diagnostic light wiring harness is damaged or wrongly connected	Check the wiring harness of diagnostic light
The deviation of pedal 1 and pedal 2 voltage signals is too large	221	P2135	Accelerator pedal	Limp home	Accelerator pedal or the wiring harness connector is damaged	Check wiring harness voltage or replace accelerator pedal
Low idling speed switch and the voltage signal between pedal 1 and pedal 2 and are untrusted	221	P2135	Accelerator pedal 1, accelerator pedal 2	The constant speed of engine is 1000rpm, accelerator pedal failure, saving flash code and the flash code light is activated	When using single modulus accelerator, the voltage signal deviation of accelerator pedal is too large at low idling speed	Check whether accelerator pedal is normal, replace accelerator pedal; check the related circuit and connector of accelerator pedal for short circuit and open circuit; check whether the circuit of accelerator pedal is interfered by other circuits
The deviation of remote pedal 1 voltage signal and remote pedal 2 voltage signal is too large	229	P1505	Remote accelerator pedal 1 and 2	The constant speed of engine is 1000rpm, remote accelerator pedal failure, saving flash code and the flash code light is activated	The difference between half of the voltage value of remote accelerator pedal 1 and the voltage of remote accelerator pedal 2 is more than 0.18V	Check whether the remote accelerator pedal is normal, replace remote accelerator pedal; check the related circuit and connector of remote accelerator pedal for short circuit and open circuit; check whether the circuit of remote accelerator pedal is interfered by other circuits
T50 switch error	345	P2530	T50 switch	Saving flash cod, flash code light activated	The closing time of T50 is more than 20s	Check whether T50 switch can be disconnected normally; check whether T50 pin and wiring harness is shorted to the external power

Description	Flash codes	P-Code	Components Related	Problem caused	Error Reasons	Solutions
CAN communication error of intake temperature signal after intercooler	233	P0099	CAN bus	The last normal value or default value is taken as the intake temperature after intercooler, affecting engine combustion, evenly appearing black smoke or insufficient power; saving flash code and flash code light activated	The intake temperature signal after intercooler from CAN bus is lost	Check the voltage of communication CAN with universal meter, under normal condition, CANH is about 2.8V and CANL is about 2.3V; if the voltage is abnormal, check whether there is short circuit and open circuit on CAN wiring harness or interfered by other wiring harness
The voltage signal of intake temperature sensor after intercooler is higher than the upper limit	233	P0098	Intake temperature sensor after intercooler	The last normal value or default value is taken as the intake temperature after intercooler, affecting engine combustion, evenly appearing black smoke or insufficient power; saving flash code and flash code light activated	The voltage signal of intake temperature sensor after intercooler is higher than 4.978V	Check whether the intake temperature sensor after intercooler is normal; measure the pin voltage of intake temperature sensor after intercooler with universal meter, determine whether it is shorted to external power; check whether related wiring harness and connector is damaged leading to short circuit or open circuit

Description	Flash codes	P-Code	Components Related	Problem caused	Error Reasons	Solutions
The voltage signal of intake temperature sensor after intercooler is less than the lower limit	233	P0097	Intake temperature sensor after intercooler	The last normal value or default value is taken as the intake temperature after intercooler, affecting engine combustion, evenly appearing black smoke or insufficient power; saving flash code and flash code light activated	The voltage signal of intake temperature sensor after intercooler is lower than 0.137V	Check whether intake temperature sensor after intercooler is normal; measure the resistance between the pin of intake temperature sensor after intercooler and vehicle ground, determine whether it is shorted to ground, the normal resistance should be >1MΩ; check whether related wiring harness and connector are damaged leading to short circuit
Intake temperature after intercooler is untrusted	233	P0096	Intake temperature sensor after intercooler	The last normal value or default value is taken as the intake temperature after intercooler, affecting engine combustion, evenly appearing black smoke or insufficient power; saving flash code and flash code light activated	The temperature difference between two successive collection of intake temperature sensor after intercooler is more than 40°C	Check whether intake temperature sensor after intercooler is normal; check the sensor and related circuit for short circuit and open circuit or whether it is interfered by other circuit
The voltage signal of ECU internal temperature sensor is higher than the upper limit	119	P0669	ECU internal temperature sensor	The last normal value or default value is taken as the ECU internal temperature	The voltage signal of ECU internal temperature sensor is higher than 2.847V	Replace ECU

Description	Flash codes	P-Code	Components Related	Problem caused	Error Reasons	Solutions
The voltage signal of ECU internal temperature sensor is less than the lower limit	119	P0668	ECU internal temperature sensor	The last normal value or default value is taken as the ECU internal temperature	The voltage signal of ECU internal temperature sensor is lower than 0.7034V	Replace ECU
The voltage of upstream temperature sensor of intake valve exceeds the maximum	236	P0113	Upstream intake temperature sensor	The last normal value or default value is taken as the upstream intake temperature, affecting engine combustion, evenly appearing black smoke or insufficient power; saving flash code and flash code light activated	The voltage signal of upstream intake temperature sensor is higher than 3.2V	Check whether the upstream intake temperature sensor is normal; measure the voltage of upstream intake temperature sensor pin with universal meter, determine whether it is shorted to external power; check whether related wiring harness and connector are damaged leading to short circuit or open circuit
The voltage of upstream temperature sensor of intake valve is less than the minimum	236	P0112	Upstream temperature sensor of intake valve	The last normal value or default value is taken as the upstream intake temperature, affecting engine combustion, evenly appearing black smoke or insufficient power; saving flash code and flash code light activated	The voltage signal of upstream intake temperature sensor is lower than 0.2V	Check whether the upstream intake temperature sensor is normal; measure the resistance between upstream intake temperature sensor pin and vehicle ground, determine whether it is shorted to ground, the normal resistance should be >1MΩ; check whether related wiring harness and connector are damaged leading to short circuit

Description	Flash codes	P-C code	Components Related	Problem caused	Error Reasons	Solutions
CAN communication error of downstream temperature sensor signal of SCR catalyst	448	U0113	CAN bus	The last normal value or default value is taken as the downstream temperature of SCR catalyst	The downstream temperature signal of SCR catalyst from CAN bus is lost	Check the voltage of communication CAN with universal meter, under normal condition, CANH Is about 2.8V, CANL is about 2.3V. If the voltage is abnormal, check whether CAN wiring harness is short circuit or open circuit or interfered by other wiring harness
The voltage of downstream temperature sensor of SCR catalyst is higher than the upper limit	448	P0428	Downstream exhaust temperature sensor of exhaust pipe	The last normal value or default value is taken as the downstream temperature of catalyst SCR	The voltage signal of downstream exhaust temperature sensor is higher than 3.3V	Check whether the downstream exhaust temperature sensor is normal, the normal resistance is about 180Ω at normal temperature. Measure the voltage of pin K55 and K56 with universal meter, determine whether it is shorted to external power. Check whether related wiring harness and connector are damaged leading to be shorted to external power
The voltage of downstream temperature sensor of SCR catalyst is less than the lower limit	448	P0427	Downstream exhaust temperature sensor of exhaust pipe	The last normal value or default value is taken as the downstream temperature of catalyst SCR	The voltage signal of downstream exhaust temperature sensor is lower than 0.2V	Check whether the downstream exhaust temperature sensor is normal, the normal resistance is about 180Ω at normal temperature. Measure the resistance from pin K55/K56 to vehicle ground with universal meter, determine whether it is shorted to ground, the normal resistance is >1MΩ. Check whether related wiring harness and connector are damaged leading to short circuit
CAN communication error of upstream temperature sensor signal of SCR catalyst	448	U0113	CAN bus	The last normal value or default value is taken as the downstream temperature of SCR catalyst; saving flash code, activating flash code light and OBD light	The upstream temperature signal of SCR catalyst from CAN bus is lost	Check the voltage of communication CAN with universal meter, under normal condition, CANH Is about 2.8V, CANL is about 2.3V. If the voltage is abnormal, check whether CAN wiring harness is short circuit or open circuit or interfered by other wiring harness

Description	Flash codes	P-Code	Components Related	Problem caused	Error Reasons	Solutions
The voltage of upstream temperature sensor of SCR catalyst is higher than the upper limit	448	P042D	Upstream exhaust temperature sensor of exhaust pipe	The last normal value or default value is taken as the upstream temperature of SCR catalyst; saving flash code, activating flash code light and OBD light	The voltage signal of upstream exhaust temperature sensor is higher than 4.7V	Check whether the upstream exhaust temperature sensor is normal, the normal resistance is about 180Ω at normal temperature. Measure the voltage of pin K81 and K82 with universal meter, determine whether it is shorted to external power. Check whether related wiring harness and connector are damaged leading to be shorted to external power
The voltage of upstream temperature sensor of SCR catalyst is less than the lower limit	448	P042C	Upstream exhaust temperature sensor of exhaust pipe	The last normal value or default value is taken as the upstream temperature of SCR catalyst; saving flash code, activating flash code light and OBD light	The voltage signal of upstream exhaust temperature sensor is lower than 0.3V	Check whether the upstream exhaust temperature sensor is normal, the normal resistance is about 180Ω at normal temperature. Measure the resistance from pin K81/K82 to vehicle ground with universal meter, determine whether it is shorted to ground, the normal resistance is >1MΩ. Check whether related wiring harness and connector are damaged leading to short circuit
The liquid level of urea is low	445	P203F	Urea tank, urea liquid level sensor	Affecting urea injection; The urea liquid level is incorrect; Activating flash code light and OBD light, saving flash code	Low urea level and urea liquid level sensor fault	Check urea liquid level, timely add urea; check whether the actual liquid level is corresponding to the indicated reading, if the deviation is large, check the floater of urea liquid level sensor for floating state
The current of SCR urea nozzle exceeds the maximum	453	P2049	Urea nozzle	Easy to damage the urea nozzle; excessive urea injection; saving flash code; activating flash code light and OBD light	The current of urea nozzle exceeds the maximum allowable current	Check whether urea nozzle operate normally; check the solenoid valve of urea nozzle for short circuit or damage, the normal resistance is about 13Ω



Description	Flash codes	P-Code	Components Related	Problem caused	Error Reasons	Solutions
SCR urea nozzle overheated	453	P3009	Power supply module of urea nozzle drive	ECU cut off the power supply module of urea nozzle drive automatically; urea nozzle stop working; saving flash code; activating flash code light and OBD light	Power supply module of ECU internal urea nozzle drive overheated	Disconnect ECU for cooling to make sure that ECU is installed where ventilation and heat dissipation is good; if this fault often happens, replace the ECU
SCR urea nozzle drive is shorted to power supply	453	P2049	Urea nozzle	Urea nozzle stop working; saving flash code; activating flash code light and OBD light	The low-end drive pin K09 of urea nozzle is shorted to power supply	Measure the voltage of pin K09 with universal meter; check whether wiring harness or connector are damaged leading to be shorted to external power
The high-end of SCR urea nozzle is shorted to power supply	453	P2049	Urea nozzle	Urea nozzle stop working; saving flash code; activating flash code light and OBD light	High-end drive pin K10 of urea nozzle is shorted to power supply or open circuit	Measure the voltage of pin K10 with universal meter; check whether wiring harness or connector are damaged leading to be shorted external power; check the open-short state between pin and nozzle, judge whether it is open circuit
SCR urea nozzle drive is shorted to ground	453	P2048	Urea nozzle	Urea nozzle stop working; saving flash code; activating flash code light and OBD light	Low-end drive pin K09 of urea nozzle is shorted to ground or open circuit	Check the resistance from pin K09 to the vehicle ground with universal meter, the normal value is $>1M\Omega$. If not, check whether wiring harness or connector are damaged leading to be shorted to ground; check the open-short state of pin and nozzle, determine whether it is open circuit

Description	Flash codes	P-Code	Components Related	Problem caused	Error Reasons	Solutions
The drive high end of SCR urea nozzle is short circuit	453	P2047	Urea nozzle	Urea nozzle stop working; saving flash code; activating flash code light and OBD light	The high end drive of urea nozzle pin K10 is shorted to power or ground or open circuit	Check the resistance from pin K10 to the vehicle ground with universal meter, the normal value is $>1M\Omega$, if not, check whether wiring harness or connector are damaged leading to be shorted to ground; check the voltage of urea nozzle pin, determine whether it is shorted to external power; check the open-short state of pin and nozzle and whether it is open circuit
Speed signal CAN communication error	224	U1405	CAN bus	The vehicle speed of ECU is taken as default value 0	The speed signal from CAN bus is lost	Check the voltage of communication CAN with universal meter, under normal condition CANH is about 2.8V, CANL is about 2.3V; if the voltage is abnormal, check whether CAN wiring harness is short circuit or open circuit or is interfered by other wiring harness
The speed exceeds the upper limit	224	P0279	Vehicle speed sensor, speed meter module	The vehicle speed of ECU is taken as default value 0; saving flash code	The speed is over 170km/h	Check whether the speed exceeds 170km/h, if not, check whether speed sensor is installed correctly; check whether speed sensor is interfered by other wiring harness and components (e.g. instrument), affecting the stability of speed signal and resulting in speed error
The voltage signal of speed sensor is untrusted	224	P2162	Vehicle speed sensor, speed meter module	The vehicle speed of ECU is taken as default value 0 ; saving flash code	The maximum of speed signal linear voltage of is $<4.7V$, or the minimum is $>4.36V$	Check if speed sensor has been correctly installed, resulting in lower maximum voltage or higher minimum voltage; check whether speed sensor is interfered by other wiring harness and components (e.g. instrument), affecting the stability of speed signal and resulting in speed error

Description	Flash codes	P-Code	Components Related	Problem caused	Error Reasons	Solutions
Engine speed and torque do not conform with the vehicle speed	224	P0501	Vehicle speed sensor, speed meter module	The vehicle speed of ECU is taken as default 0; saving flash code	When engine speed is over 5000rpm and torque is over 300Nm, the vehicle speed is less than 10km/h (the current calibrated engine speed lower limit is 5000rpm, and in normal cases, the engine cannot reach this speed)	Check if the signal is swinging or lost, leading to vehicle speed error because of improper installation of vehicle speed sensor; Check if speed sensor is interfered by other wiring harness or components (such as instrument), affecting the stability of speed signal and resulting in speed error
Voltage signal of vehicle speed sensor exceeds the upper limit	224	P0503	Speed sensor	The vehicle speed of ECU is taken as default 0; saving flash code	When the engine runs normally for a time, the linear voltage signal of vehicle speed sensor is over the upper limit (12V) of high level	Check whether the speed sensor has been correctly installed and whether it is interfered by other wiring harness or component (such as instrument), leading to higher or instable voltage

Description	Flash codes	P-Code	Components Related	Problem caused	Error Reasons	Solutions
Voltage signal of vehicle speed sensor is under the lower limit	224	P0502	Speed sensor	The vehicle speed of ECU is taken as default 0; saving flash code	When the engine runs normally for a time, the linear voltage signal of speed sensor is under the lower limit of low level (currently, the calibrated lower limit of low level is 0, so this fault is not going to happen)	Check the connection of earth wire of sensor, whether the speed signal can be received normally; Check whether the induction voltage is weak because of improper installation of sensor; Check if the speed sensor is interfered by other wiring harness or component (such as instrument), leading to higher or instable voltage
Signal pulse width of speed sensor exceeds the upper limit	225	P2158	Speed sensor and speed meter module	The vehicle speed of ECU is taken as default 0; saving flash code	When the engine runs normally for a time, the pulse width of speed signal exceeds 5000 microseconds	Check the connection of earth wire of sensor, whether the speed signal can be received normally; Check whether the induction voltage signal is weak because of improper installation of sensor; Check if the speed sensor and speed meter are interfered by other wiring harness or component (such as instrument), leading to loss of speed pulse voltage signal
Signal pulse width of speed sensor is under the lower limit	225	P2160	Speed sensor and speed meter module	The vehicle speed of ECU is taken as default 0; saving flash code	When the engine runs normally for a time, the pulse width of speed signal is under 400 microseconds	Check if the speed sensor, speed meter and related harness are interfered by other wiring harness or component (such as instrument), leading to high frequency oscillation of speed signal; Check whether the speed meter is working normally

Description	Flash codes	P-Code	Components Related	Problem caused	Error Reasons	Solutions
Signal cycle of speed sensor is under the lower limit	225	P2161	Speed sensor and speed meter module	The vehicle speed of ECU is taken as default 0; saving flash code	When the engine runs normally for a time, pulse cycle of speed signal is under minimum period (currently, the calibrated minimum period is 0, so this fault is not going to happen)	Check if the speed sensor, speed meter and related harness are interfered by other wiring harness or component (such as instrument), leading to high frequency oscillation of speed signal; Check whether the speed meter is working normally
Alarm light open circuit	336	P1613	Flash code light	When ECU is powered on, flash code light does not light; when pressing fault request button, flash code light does not light; saving flash code	There is no load on flash code light pin	Check whether the wiring harness, fuse and connector of pin K70 and K65 are at conduction state. Check whether incandescent lamp or LED light is working normally
Alarm light overheating	336	P1614	ECU internal flash code light power supply module	ECU switches off flash code light power supply module automatically; flash code light stops working; saving flash code	Overheating of ECU internal flash code light power supply module	Disconnect ECU for cooling to make sure that ECU is installed where ventilation and heat dissipation is good; if this fault often happens, replace the ECU
Alarm light is shorted to power supply	336	P1615	Flash code light	When there is no other fault, flash code light is normally on; Saving flash code	Wiring harness of flash light pin is shorted to external power supply	Check the voltage of each pin of flash code light with multimeter; Check whether flash code light wiring harness and connector are damaged, causing shorted to the external power supply

Description	Flash codes	P-Code	Components Related	Problem caused	Error Reasons	Solutions
Alarm light is shorted to ground	336	P1616	Flash code light	When ECU is powered on, flash code light does not light; when pressing fault request button, flash code light does not light; saving flash code	Flash code light power supply pin is shorted to external ground	Check the resistance of each pin of the flash code light to the vehicle ground with multimeter, the normal value should be over 1MΩ, otherwise check whether the flash code light wiring harness and connector are damaged, leading to shorted to ground
Actual average conversion efficiency of SCR is low	430	P0420	Emission control and monitor module	OBD torque is limited; code cannot be cleared	Emission exceeds 5 or 7; original emission of the engine deteriorated; SCR conversion box deteriorated; urea spray dose error is too big; wrong calibration data	Replace relevant components of engine emission (mainly fuel system); replace or reactivate SCR conversion box; replace the components of urea spray system (such as nozzle, urea dosing pump etc.); use better diesel fuel; check calibration data
Actual average conversion efficiency of SCR is less than threshold value 1, and emission exceeds 5	431	P0420	Emission control and monitor module	Code cannot be cleared	Emission exceeds 5 original emission of the engine deteriorated; SCR conversion box deteriorated; urea spray dose error is too big; unqualified fuel; wrong calibration data	Replace relevant components of engine emission (mainly fuel system); replace or reactivate SCR conversion box; replace the components of urea spray system (such as nozzle, urea dosing pump etc.); use better diesel fuel; check calibration data

Description	Flash codes	P-Code	Components Related	Problem caused	Error Reasons	Solutions
Actual average conversion efficiency of SCR is less than threshold value 2, and emission is over 7	432	P0420	Emission control and monitor module	OBD torque is limited; code cannot be cleared	Emission is over 7 original emission of the engine deteriorated; SCR conversion box deteriorated; urea spray dose error is too big; unqualified fuel; wrong calibration data	Replace relevant components of engine emission (mainly fuel system); replace or reactivate SCR conversion box; replace the components of urea spray system (such as nozzle, urea dosing pump etc.); use better diesel fuel; check calibration data
The signal peak detection of NOx sensor at downstream of SCR is untrusted	421	P2214	Emission control and monitor module	After 50 hours, OBD torque is limited, code cannot be cleared	Slow NOx signal response of NOx sensor; NOx sensor fault; wrong installation position of NOx sensor; exhaust pipe is blocked; wrong calibration data	Replace NOx sensor; reinstall NOx sensor according to specification; check blockage condition of exhaust pipe; check calibration data
Urea spray is not released	436	P3042	Emission control and monitor module	After 50 hours, OBD torque is limited, code cannot be cleared	Nozzle electrical fault; nozzle gets stuck at normal closed position; ECU hardware fault	Check the nozzle, and replace it when necessary; replace ECU

Description	Flash codes	P-Code	Components Related	Problem caused	Error Reasons	Solutions
SCR urea return pipe is untrusted	441	P3050	Return pipe of urea dosing pump	DetMode cannot pass, and urea cannot be sprayed	Return pipe cannot release pressure	Check if return pipe or connector is blocked
Pressure drop error of SCR urea spray pressure	441	P3053	Pressure pipe of urea dosing pump	DetMode cannot pass, and urea cannot be sprayed	Pressure pipe cannot release pressure	Check if pressure pipe or connector is blocked
SCR urea spray pressure error	441	P3054	Urea dosing pump and hydraulic pipeline	DetMode cannot pass, and the torque is limited immediately	Pressure is unstable	Check the pipeline for leakage or blockage
Internal temperature of ECU is over the upper limit	119	P0669	ECU	SCR system is closed, and urea cannot be sprayed	ECU temperature is over high	Check the reason for overheating
SCR was not discharged completely at the end of last driving cycle	447	P3015	Hydraulic pipeline	Have no effect on system operation	Reverse pumping is not complete	Reverse pumping completely

Description	Flash codes	P-Code	Components Related	Problem caused	Error Reasons	Solutions
Urea spray pressure metered and controlled by SCR urea dosing pump is too high	442	P3039	Hydraulic pipeline	The system is overpressure, and the torque is limited after 50 hours	Blockage	Check hydraulic pipeline
Urea spray pressure metered and controlled by SCR urea dosing pump is too low	443	P3056	Hydraulic pipeline	Urea is not sprayed due to low system pressure; the torque is limited immediately	Leakage	Check hydraulic pipeline
When SCR urea dosing pump has been frozen, urea spray pressure is too high	442	P3039	Hydraulic pipeline	The system pressure is too high, and urea cannot be sprayed	Blockage	Check hydraulic pipeline
SCR urea pressure buildup error	441	P3040	Urea dosing pump and hydraulic pipeline	Pressure buildup fails, and SCR system stops working. The torque is limited after 50 hours	Leakage; there is no urea	Check hydraulic pipeline
Pressure drop error of SCR urea pressure	441	P3049	Urea dosing pump and hydraulic pipeline	Pressure releasing fails, and SCR system stops working; The torque is limited after 50 hours	Unfreezing of partial urea fails	Continue unfreezing
After pressure drop, SCR urea pressure is not less than limiting value	441	P3041	Urea dosing pump and hydraulic pipeline	Pressure is not reduced to the target value; SCR system stops working	Reversing valve failure or pipeline blocked	Check reversing valve and the pipeline

Description	Flash codes	P-Code	Components Related	Problem caused	Error Reasons	Solutions
Urea tank overheating	446	P2043	Urea tank	Urea is not sprayed; temperature overheated, and the finite state machine switched to pressureless control status	Urea tank temperature SCR_tUTnkT is over the upper limit SCRPOD_tMonTnkTempMax_C continuously	Stop heating; Cooling
The times that SCR urea solution is not added in time exceeds allowed maximum	438	P2068	Urea	When FId_SCRRCntErr is locked, SCRctl_stDrvCyclEnbl_mp is reset; Initialization of urea spray quantity is prohibited	Liquid level of urea tank is under certain limiting value	Refill urea to make the liquid level not under fault limiting value
The voltage of urea liquid level sensor is higher than the upper limit	445	P203D	Urea liquid level sensor	Limit the torque after 50h	Bad contact of sensor connector, open circuit or shorted to power supply; sensor original voltage SCR_uRawUTnkLvl is over the voltage upper limit SCR_SRCUTnkLvl.uMax_C	1. Fasten or replace connector or wiring harness; 2. Replace the sensor; 3. Check the calibration of the upper limit of voltage

Description	Flash codes	P-Code	Components Related	Problem caused	Error Reasons
The voltage of urea level sensor is less than the lower limit	445	P203C	Urea liquid level sensor	Limit the torque after 50h	Sensor connector is shorted to ground; sensor original voltage SCR_uRawUTnkLvl is under the voltage lower limit SCR_SRCUTnkLvl.uMin_C
Duty ratio of SCR urea dosing pump heater temperature is in the wrong range	455	P3029	SCR urea dosing pump heater	Urea dosing pump cannot be heated	Duty ratio of SCR urea dosing pump heater temperature is less than the maximum and larger than the minimum, i.e. $SCR_rSMFailMin_C \leq SCR_rSMHtrT \leq SCR_rSMFailMax_C$
Duty ratio of SCR urea dosing pump heater temperature is in an invalid range	455	P3029	SCR urea dosing pump heater	Urea dosing pump cannot be heated	Duty ratio of SCR urea dosing pump heater temperature is not in valid range or is not in wrong range, i.e. $(SCR_rSMHtrT < SCR_rSMHtrTVldMin_C) \text{ OR } (SCR_rSMHtrTVldMax_C < SCR_rSMHtrT < SCR_rSMFailMin_C) \text{ OR } (SCR_rSMHtrT > SCR_rSMFailMax_C)$
SCR urea dosing pump temperature measurement module failure	454	P3038	SCR urea dosing pump temperature measurement module	Unable to get the temperature of urea dosing pump	Temperature metering unit failure; after the starting times exceeds the maximum rated value, temperature measurement still fails

Description	Flash codes	P-Code	Components Related	Problem caused	Error Reasons	Solutions
PWM cycle received by SCR urea dosing pump is in invalid range	454	P2062	SCR urea dosing pump	Unable to get signals	The PWM cycle range received by SCR urea dosing pump is beyond 150ms and 250ms	Check or replace urea dosing pump
SCR urea dosing pump temperature duty ratio is in wrong range	456	P3029	SCR urea dosing pump	Limit the torque immediately ; unable to get signals	Urea dosing pump temperature duty ratio is in wrong range (i.e. $SCR_rSMFailMin_C \leq SCR_rSMT \leq SCR_rSMFailMax_C$)	Check or replace urea dosing pump
SCR urea dosing pump temperature duty ratio is in invalid range	456	P3029	SCR urea dosing pump	Limit the torque immediately ; unable to get signals	Urea dosing pump temperature duty ratio is in invalid range (i.e. $SCR_rSMT < SCR_rSMTVldMin_C$ or $(SCR_rSMTVldMax_C < SCR_rSMT < SCR_rSMFailMin_C)$ or $(SCR_rSMT > SCR_rSMFailMax_C)$)	Check or replace urea dosing pump
SCR urea dosing pump PWM signal error	454	P2062	SCR urea dosing pump	Unable to get signals		Check or replace urea dosing pump
Urea tank temperature CAN information error	446	P205A	Urea tank temperature sensor	Unable to read urea tank temperature	Information read from Com_tUTnkT is equal to 0x7FFF	Check ECU communication; replace the sensor
Voltage signal of urea tank temperature sensor is above the upper limit	446	P205D	Urea tank temperature sensor	The sensor is open circuit; Unable to get the temperature	The connection is loose or open circuit; urea tank temperature sensor voltage SCR_uRawUTnkT is above the upper limit SCR_SRCUTnkT.uMax_C	Check and fasten the connector; replace the sensor
Voltage signal of urea tank temperature sensor is below the lower limit	446	P205C	Urea tank temperature sensor	The sensor is short circuit; Unable to get the temperature	The connector pin is short circuit; urea tank temperature sensor voltage SCR_uRawUTnkT is below the lower limit SCR_SRCUTnkT.uMin_C	Check if the connector is short circuit; replace the sensor

Description	Flash codes	P-Code	Components Related	Problem caused	Error Reasons	Solutions
Urea heating error	433	P3025	Urea heating error	SCR heating system stops immediately; SCR urea spray system stops working,	Urea heater cannot work, with error DINH_stFId.FId_UHCPresLineErr; as long as there is one heating pipeline cannot work (total 3 pipelines) and urea tank temperature is too low and heating is needed, in order to prevent urea pressure pipe from being frozen, it will report this error, and stop SCR system immediately. At this time, please check whether urea tank temperature sensor and wiring harness connection are normal	Generally, if this error appeared accompanied by other heating errors, check the heating of each pipeline and urea tank temperature sensor or the wire harness. After the problem has been resolved, restart the vehicle and eliminate the errors
The urea tank temperature sensor signal is above the upper limit	446	P205B	Urea tank temperature sensor	The temperature is too high	The urea tank temperature sensor signal SCR_tUTnkT-EnvT_t is above the upper limit SCR_tUTnkTMaxDiff_C	Check the urea temperature in urea tank and environment temperature with diagnostic equipment
The urea tank temperature sensor signal is below the lower limit	446	P205B	Urea tank temperature sensor	The temperature is too low	The urea tank temperature sensor signal SCR_tUTnkT-EnvT_t is below the lower limit SCR_tUTnkTMinDiff_C	Check the urea temperature in urea tank and environment temperature with diagnostic equipment
Feedback of urea pipe (pump to tank) heating resistance wire is untrusted	461	P3069	Urea pipe (pump to tank) heating resistance wire	Unable to work	Feedback voltage of urea pipe (pump to tank) heating resistance wire UHC_uBLFdBk is between UHC_uADCLow_C and UHC_uADCHigh_C	Check urea return pipe heating resistance wire, closed-open of pin K36 and K50 and feedback voltage for abnormal

Description	Flash codes	P-Code	Components Related	Problem caused	Error Reasons	Solutions
Urea pipe (pump to tank) heating resistance wire is open circuit	461	P3070	Urea pipe (pump to tank) heating resistance wire	Unable to work	Urea pipe (pump to tank) heating resistance wire UHtrRlyisONandUHtrBLisONandADCinput UHC_BLAdcFeedback is on the high side	Check urea return pipe heating resistance wire, closed-open of pin K36 and K50 and feedback voltage for abnormal
Urea pipe (pump to tank) heating resistance wire is shorted to ground or open circuit	461	P3071	Urea pipe (pump to tank) heating resistance wire	Unable to work	The heating resistance wire end of urea pipe (pump to tank) is earthed	Check urea return pipe heating resistance wire, closed-open of pin K36 and K50 and feedback voltage for abnormal
Urea pipe (pump to tank) heating relay is open circuit	461	P3021	Urea pipe (pump to tank) heating relay	Unable to work	Urea pipe (pump to tank) heating relay is open circuit	Check urea return pipe heating relay, closed-open of pin K50 and voltage for abnormal; Check ECU pins when necessary
Urea pipe (pump to tank) heating relay overheated	461	P3072	Urea pipe (pump to tank) heating relay	Heating relay is powered off; unable to work	The temperature of urea pipe (pump to tank) heating relay is too high	Check urea return pipe heating relay, closed-open of pin K50 and voltage for abnormal; Check ECU pins when necessary

Description	Flash codes	P-Code	Components Related	Problem caused	Error Reasons	Solutions
Urea pipe (pump to tank) heating relay is shorted to power supply	461	P3023	Urea pipe (pump to tank) relay	Unable to work	Urea pipe (pump to tank) heating relay is shorted to power supply	Check closed-open of urea return pipe heating relay pin, and check feedback voltage for abnormal
Urea pipe (pump to tank) heating relay is shorted to ground	461	P3022	Urea pipe (pump to tank) heating relay	Unable to work	The heating relay end of urea pipe (pump to tank) is earthed	Check urea return pipe heating relay, closed-open of pin K26; check feedback voltage for abnormal; check for pin grounding or pin lapping when necessary
Feedback of urea pipe (pump to nozzle) heating resistance wire is untrusted	462	P3073	Urea pipe (pump to nozzle) heating resistance wire	Unable to work	The voltage of urea pipe (pump to nozzle) heating resistance wire UHC_uPLFdBk is in between UHC_uADCLow_C and UHC_uADCHigh_C	Check urea pressure pipe heating resistance wire, closed-open of pin K58 and K92; check the feedback voltage for abnormal
Urea pipe (pump to nozzle) heating resistance wire is open circuit	462	P3074	Urea pipe (pump to nozzle) heating resistance wire	Unable to work	Urea pipe (pump to nozzle) heating resistance wire is open circuit	Check urea pressure pipe heating resistance wire, closed-open of pin K58 and K92; check the feedback voltage for abnormal
Urea pipe (pump to nozzle) heating resistance wire is shorted to ground or open circuit	462	P3075	Urea pipe (pump to nozzle) heating resistance wire	Unable to work	Urea pipe (pump to nozzle) heating resistance wire is shorted to ground	Check urea pressure pipe heating resistance wire, closed-open of pin K58 and K92; check the feedback voltage for abnormal

Description	Flash codes	P-Code	Components Related	Problem caused	Error Reasons	Solutions
Urea pipe (pump to nozzle) heating relay is open circuit	462	P3024	Urea pipe (pump to nozzle) heating relay	Unable to work, and SCR system does not work	Urea pipe (pump to nozzle) heating relay is open circuit	Check urea pressure pipe heating relay, closed-open of pin K92 and K58; check the feedback voltage for normal; check for pin grounding or pin lapping of ECU when necessary
Urea pipe (pump to nozzle) heating relay is overheating	462	P3076	Urea pipe (pump to nozzle) heating relay	Heating relay is powered off; unable to work	The temperature of urea pipe (pump to nozzle) heating relay is to high	Check urea pressure pipe heating relay, closed-open of pin K92 and K58; check the feedback voltage for normal; check for pin grounding or pin lapping of ECU when necessary
Urea pipe (pump to nozzle) heating relay is shorted to power supply	462	P3027	Urea pipe (pump to nozzle) heating relay	Unable to work, and SCR system does not work	Urea pipe (pump to nozzle) heating relay is shorted to power supply	Check urea pressure pipe heating relay, closed-open of pin K92 and K58; check the feedback voltage for normal; check for pin grounding or pin lapping of ECU when necessary
Urea pipe (pump to nozzle) heating relay is shorted to ground	462	P3026	Urea pipe (pump to nozzle) heating relay	Unable to work, and SCR system does not work	The urea pipe (pump to nozzle) heating relay end is earthed	Check urea pressure pipe heating relay, closed-open of pin K92 and K58; check the feedback voltage for normal; check for pin grounding or pin lapping of ECU when necessary

Description	Flash codes	P-Code	Components Related	Problem caused	Error Reasons	Solutions
The load of urea heating main relay is shorted to power supply	463	P3077	Urea heating main relay	Unable to work	The load of urea heating main relay is shorted to power supply	Check closed-open of K94 and K90 of urea heating main relay; check the feedback voltage for abnormal; check for pin grounding or pin lapping of ECU when necessary
Urea heating main relay is open circuit	463	P3043	Urea heating main relay	Unable to work	The load of urea heating main relay is open circuit	Check closed-open of K94 and K90 of urea heating main relay; check the feedback voltage for abnormal; check for pin grounding or pin lapping of ECU when necessary
The drive of urea heating main relay is overheating	463	P3044	Urea heating main relay	Unable to work	The temperature of the drive of urea heating main relay is too high	Check closed-open of K94 and K90 of urea heating main relay; check the feedback voltage for abnormal; check for pin grounding or pin lapping of ECU when necessary
Urea heating main relay is shorted to power supply	463	P3045	Urea heating main relay	Unable to work	Urea heating main relay is shorted to power supply	Check closed-open of K94 and K90 of urea heating main relay; check the feedback voltage for abnormal; check for pin grounding or pin lapping of ECU when necessary
Urea heating main relay is shorted to ground	463	P3046	Urea heating main relay	Unable to work	Urea heating main relay is shorted to ground	Check closed-open of K94 and K90 of urea heating main relay; check the feedback voltage for abnormal; check for pin grounding or pin lapping of ECU when necessary

Description	Flash codes	P-Code	Components Related	Problem caused	Error Reasons	Solutions
Feedback of urea pipe (tank to pump) heating resistance wire is untrusted	464	P3078	Urea pipe (tank to pump) heating resistance wire	Unable to work	Urea pipe (tank to pump) heating resistance wire feedback voltage UHC_uSLFdBk is in between UHC_uADCLow_C and UHC_uADCHigh_C	Check urea pipe heating resistance wire; check closed-open of K20 and K26 pin; check feedback voltage for abnormal
Urea pipe (tank to pump) heating resistance wire is open circuit	464	P3079	Urea pipe (tank to pump) heating resistance wire	Unable to work	Urea pipe (tank to pump) heating resistance wire is open circuit	Check urea sucker heating resistance wire, closed-open of pin K20 and K26, and feedback voltage for abnormal; check for pin grounding or pin lapping of ECU when necessary
Urea pipe (tank to pump) heating resistance wire is shorted to ground or open circuit	464	P3080	Urea pipe (tank to pump) heating resistance wire	Unable to work	Urea pipe (tank to pump) heating resistance wire is shorted to ground	Check urea sucker heating resistance wire, closed-open of pin K20 and K26, and feedback voltage for abnormal; check for pin grounding or pin lapping of ECU when necessary
Urea pipe (tank to pump) heating relay is open circuit	464	P3028	Urea pipe (tank to pump) heating relay	Unable to work	Urea pipe (tank to pump) heating relay is open circuit	Check closed-open of urea sucker heating relay, and check the feedback voltage for abnormal; check for pin grounding or pin lapping of ECU when necessary

Description	Flash codes	P-Code	Components Related	Problem caused	Error Reasons	Solutions
Urea pipe (tank to pump) heating relay is overheating	464	P3081	Urea pipe (tank to pump) heating relay	Unable to work	The temperature of urea pipe (tank to pump) heating relay is too high	Check closed-open of urea sucker heating relay, and check the feedback voltage for abnormal; check for pin grounding or pin lapping of ECU when necessary
Urea pipe (tank to pump) heating relay is shorted to power supply	464	P3032	Urea pipe (tank to pump) heating relay	Unable to work	Urea pipe (tank to pump) heating relay is shorted to power supply	Check closed-open of urea sucker heating relay, and check the feedback voltage for abnormal
Urea pipe (tank to pump) heating relay is shorted to ground	464	P3031	Urea pipe (tank to pump) heating relay	Unable to work	Urea pipe (tank to pump) heating relay is shorted to ground	Check closed-open of urea sucker heating relay, and check the feedback voltage for abnormal; Check for pin grounding or pin lapping of ECU when necessary
Feedback of urea dosing pump heating resistance wire is untrusted	465	P3082	Urea dosing pump heating resistance wire	Unable to work	The diagnosis failure of relay load; the feedback voltage UHC_uSMFdBk of urea dosing pump heating resistance wire is in between UHC_uADCLow_C and UHC_uADCHigh_C	Check urea dosing pump heating resistance wire, closed-open of pin K33 and K25 and the feedback voltage for abnormal normal; Check for pin grounding or pin lapping of ECU when necessary

Description	Flash codes	P-Code	Components Related	Problem caused	Error Reasons	Solutions
Urea dosing pump heating resistance wire is open circuit	465	P3083	Urea dosing pump heating resistance wire	Unable to work	Urea dosing pump heating resistance wire is open circuit	Check urea dosing pump heating resistance wire, closed-open of pin K33 and K25 and the feedback voltage for abnormal; Check for pin grounding or pin lapping of ECU when necessary
Urea dosing pump heating resistance wire is shorted to ground or open circuit	465	P3084	Urea dosing pump heating resistance wire	Unable to work	Urea dosing pump heating resistance wire is shorted to ground	Check urea dosing pump heating resistance wire, closed-open of pin K33 and K25 and the feedback voltage for abnormal; Check for pin grounding or pin lapping of ECU when necessary
Urea dosing pump heating relay is open circuit	465	P3033	Urea dosing pump heating relay	Unable to work	K25 of urea dosing pump heating relay is open circuit	Check urea dosing pump heating relay, closed-open of, connector pin K90 and K25, and check the feedback voltage for abnormal; Check for pin grounding or pin lapping of ECU when necessary
Urea dosing pump heating relay is overheating	465	P3085	Urea dosing pump heating relay	Unable to work	The temperature of urea dosing pump heating relay is too high	Check urea dosing pump heating relay, closed-open of, connector pin K90 and K25, and check the feedback voltage for abnormal; Check for pin grounding or pin lapping of ECU when necessary
Urea dosing pump heating relay is shorted to power supply	465	P3037	Urea dosing pump heating relay	Unable to work	Urea dosing pump heating relay K25 is shorted to power supply	Check urea dosing pump heating relay, closed-open of, connector pin K90 and K25, and check the feedback voltage for abnormal; Check for pin grounding or pin lapping of ECU when necessary



Description	Flash codes	P-Code	Components Related	Problem caused	Error Reasons	Solutions
Urea dosing pump heating relay is shorted to ground	465	P3036	Urea dosing pump heating relay	Unable to work	Urea dosing pump heating relay K25 is shorted to ground	Check urea dosing pump heating relay, closed-open of, connector pin K90 and K25, and check the feedback voltage for abnormal; Check for pin grounding or pin lapping of ECU when necessary
Urea tank heating solenoid valve is open circuit	466	P3016	Urea tank heating solenoid valve	Urea tank cannot be heated	K28/K89 of urea tank heating solenoid valve is open circuit	Check closed-open of urea heating solenoid valve K89 and K28, and check the feedback voltage for abnormal. Check for pin grounding or pin lapping of ECU when necessary
Urea tank heating solenoid valve is overheating	466	P3018	Urea tank heating solenoid valve	Urea tank cannot perform heating function	The temperature of urea tank heating solenoid valve is too high	Check closed-open of urea heating solenoid valve K89 and K28, and check the feedback voltage for abnormal. Check for pin grounding or pin lapping of ECU when necessary
Urea tank heating solenoid valve is shorted to power supply	466	P3020	Urea tank heating solenoid valve	Urea tank cannot be heated	Urea tank heating solenoid valve K28 is shorted to power supply	Check closed-open of urea heating solenoid valve K89 and K28, and check the feedback voltage for abnormal. Check for pin grounding or pin lapping of ECU when necessary
Urea tank heating solenoid valve is shorted to ground	466	P3019	Urea tank heating solenoid valve	Urea tank cannot be heated	Urea tank heating solenoid valve K28 is shorted to ground	Check closed-open of urea heating solenoid valve K89 and K28, and check the feedback voltage for abnormal. Check for pin grounding or pin lapping of ECU when necessary

Description	Flash codes	P-Code	Components Related	Problem caused	Error Reasons	Solutions
Urea dosing pump motor speed deviation is wrong	451	P3001	Urea dosing pump motor	Limit the torque after 50h	Urea dosing pump motor is damaged	Check or replace urea dosing pump
Urea dosing pump motor long time speed deviation is wrong	451	P3086	Urea dosing pump motor	Limit the torque after 50h	Urea dosing pump motor is damaged	Check or replace urea dosing pump
Urea dosing pump motor failure	451	P3002	Urea dosing pump motor	Limit the torque immediately	After urea dosing pump motor temperature measuring mode, it cannot switch to urea dosing pump activation mode	Check or replace urea dosing pump
Urea dosing pump motor drive is open circuit	451	P3006	Urea dosing pump motor drive	Limit the torque immediately	Urea dosing pump motor drive is open circuit	Check or replace urea dosing pump
Urea dosing pump motor drive is overheating	451	P3003	Urea dosing pump motor drive	Limit the torque immediately	The temperature of urea dosing pump motor drive is too high	Cooling; check or replace urea dosing pump
Urea dosing pump motor drive is shorted to power supply	451	P3004	Urea dosing pump motor drive	Limit the torque immediately	Urea dosing pump motor drive is shorted to power supply	Check or replace urea dosing pump
Urea dosing pump motor drive is shorted to ground	451	P3005	Urea dosing pump motor drive	Limit the torque immediately	Urea dosing pump motor drive is shorted to ground	Check or replace urea dosing pump
The pressure of urea dosing pump is higher than the upper limit	451	P3007	Urea dosing pump pressure sensor	Limit the torque immediately	Pipeline is blocked; the nozzle is blocked; urea dosing pump pressure SCR_pUPmpPPlausDiff_mp is higher than the upper limit pUPmpPPlausMaxDiff_mp	Check the pipeline and nozzle for blockage
The pressure of urea dosing pump is below the lower limit	451	P3007	Urea dosing pump pressure sensor	Limit the torque immediately	There is air in the pipeline or leaking; urea dosing pump pressure SCR_pUPmpPPlausDiff_mp is below the lower limit SCR_pUPmpPPlausMinDiff_mp	Check the pipeline for air or leakage and check for wrong connection of pipeline
Urea dosing pump pressure signal CAN communication error	451	P204E	Urea dosing pump pressure sensor	Unable to get signals; unable to spray	Urea dosing pump pressure signal Com_pAbsUpmpP from CAN is equal to 0x7FFF	Check ECU and pump communication; check the connection



Description	Flash codes	P-Code	Components Related	Problem caused	Error Reasons	Solutions
Voltage signal of urea dosing pump pressure sensor is higher than the upper limit	451	P204D	Urea dosing pump pressure sensor	Limit the torque immediately	Open circuit; the urea dosing pump pressure sensor voltage SCR_uRawUPmpP is higher than the upper limit SCR_SRCUPmpP.uMax_C	Check the connection of pins (K24, K28, and K77) of urea dosing pump pressure sensor and wiring harness
Voltage signal of urea dosing pump pressure sensor is less than the lower limit	451	P204C	Urea dosing pump pressure sensor	Limit the torque immediately	Short circuit; the urea dosing pump pressure sensor voltage SCR_uRawUPmpP is less than the lower limit SCR_SRCUPmpP.uMin_C	Check whether K78 is shorted to ground
The high-end of urea reversing valve actuator is open circuit	452	P3047	Urea reversing valve actuator	Urea pressure buildup fails	The high-end of urea reversing valve actuator is open circuit	Replace urea dosing pump
The high-end of urea reversing valve actuator is overheating	452	P3048	Urea reversing valve actuator	Urea pressure buildup fails	The high-end temperature of urea reversing valve actuator is too high	Replace urea dosing pump
The high-end of urea reversing valve actuator is shorted to power supply	452	P3049	Urea reversing valve actuator	Urea pressure buildup fails	The high-end of urea reversing valve actuator is shorted to power supply	Replace urea dosing pump
The high-end of urea reversing valve actuator is shorted to ground	452	P3050	Urea reversing valve actuator	Urea pressure buildup failure	The high-end of urea reversing valve actuator is shorted to ground	Replace urea dosing pump

Description	Flash codes	P-Code	Components Related	Problem caused	Error Reasons	Solutions
Urea reversing valve actuator is open circuit	452	P3010	Urea reversing valve actuator	Urea pressure buildup fails	Urea reversing valve actuator is open circuit	Replace urea dosing pump
Urea reversing valve actuator is overheating	452	P3011	Urea reversing valve actuator	Urea pressure buildup fails	The temperature of urea reversing valve actuator is too high	Check or replace urea dosing pump
Urea reversing valve actuator is shorted to power supply	452	P3013	Urea reversing valve actuator	Urea pressure buildup fails	Urea reversing valve actuator is shorted to power supply	Replace urea dosing pump
Urea reversing valve actuator is shorted to ground	452	P3012	Urea reversing valve actuator	Urea pressure buildup fails	Urea reversing valve actuator is shorted to ground	Replace urea dosing pump
CAN receiving frame AT101 data length error	421	U0113	NOx sensor	Affecting measurement accuracy for NOx	Signal interference or NOx sensor failure	Check wiring harness and power supply of battery, or replace NOx sensor
CAN receiving frame AT101 time-out error	421	U0113	NOx sensor	Unable to obtain NOx signal; Limit OBD torque after 50 hours; Code cannot be cleared	NOx sensor failure or wrong connection of NOx sensor wiring harness	Check wiring harness and power supply of battery, or replace NOx sensor

Appendix B: Fitting clearances for diesel engine main parts

(Reference value)

S/N	Items	Theoretical value (mm)
1	Main bearing clearance	0.063~0.138
2	Connecting rod bearing clearance	0.050~0.125
3	Crankshaft axial clearance	0.052~0.255
4	Axial clearance of connecting rod plane	0.15~0.35
5	Working clearance of piston ring opening (cold state):	
	First ring	0.35~0.55
	Second ring	0.60~0.70
	Oil control ring	0.30~0.50
6	Valve clearance (cold state) : intake/exhaust	0.4/0.6
7	EVB system	0.4
8	Camshaft axial clearance	0.1~0.3

Appendix C: Evaluation benchmark for wear of main friction pairs of the diesel engine

(Reference value)

	Wear limit mm	Clearance limit mm
1 st ring end gap	1.70	-
1 st ring height	0.10	-
2 nd ring end gap	1.50	-
2 nd ring height	0.10	-
Oil control ring end gap	1.50	-
Oil control ring height	0.15	-
Outer diameter of piston skirt	0.25	0.60
Inner diameter of cylinder liner	0.50	
Outer diameter of piston pin	0.04	0.10
Inner diameter of piston pin hole	0.08	
Inner diameter of small end bushing of connecting rod	0.08	
Outer diameter of camshaft main journal	0.06	0.10
Inner diameter of camshaft bushing	0.06	
Height of camshaft peach tip	2.00	-
Outer diameter of camshaft base circle	0.05	-
Outer diameter of crankshaft connecting rod journal	0.12	0.15
Inner diameter of connecting rod bearing	0.10	
Outer diameter of crankshaft main journal	0.08	0.15
Inner diameter of main bearing	0.10	
Thickness of thrust bearing	0.40	-
Intake valve sinkage	0.04*d(1)	
Intake valve seal ring	0.75	

Intake valve seat ring	0.75	
Exhaust valve sinkage	0.04*d(1)	
Exhaust valve seal ring	0.85	
Exhaust valve seat ring	0.85	
Inner diameter of intake valve guide	0.06	0.1
Outer diameter intake valve stem	0.06	
Inner diameter of exhaust valve guide	0.06	0.1
Outer diameter of exhaust valve stem	0.06	
Inner diameter of rocker shaft bushing	0.10	0.12
Outer diameter of rocker shaft	0.05	
(1): "d" refers to diameter of intake/exhaust valve disk		